

پمپ روغن داغ

STANDART PUMP



kalasanati.com



[@kalasanati.ir](https://www.instagram.com/kalasanati.ir)



[+982188544230](tel:+982188544230)

Catalog 2021

PUMP

www.kalasanati.com

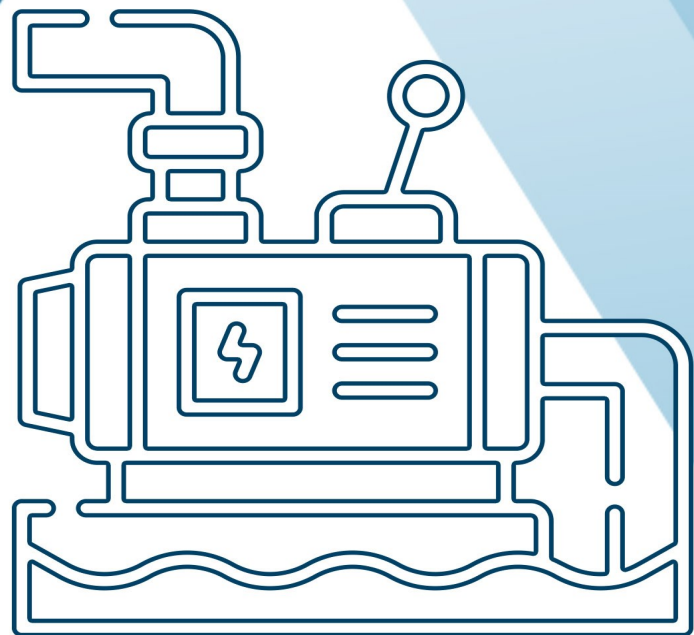



Kalasanati.com
Training, Selecting, Purchasing

Standart
Yaşamı Koru! Save Life!



Pump

Kalasanati.com







Standart

Pump • Fire Fighting Units • Booster Set



Product Catalogue



CONTENTS			Page
PUMPS			
ECO SNT		EN 733 Norm Centrifugal Pumps (Horizontal)	003
ECO SNM		Rigidly Coupled Centrifugal Pumps (Horizontal / Vertical)	011
ECO SNL		In-line Centrifugal Pumps	021
ECO SKY		Air Cooled Thermal Oil Pumps	029
ECO SNV		Sump Pump	035
SNT		Norm Centrifugal Pumps (Horizontal)	041
SNL		In-line Centrifugal Pumps	047
SKY		Air Cooled Thermal Oil Pumps	053
SCP		ISO 22858 Norm Chemical Process Pumps	057
SCP-HT		Hot Water Pumps	063
SPO		API 610 11. Edition (ISO 13709) Process Pump	067
SNMV-H		Centrifugal Pumps (Vertical)	071
SNLV-H		In-line Centrifugal Pumps - With Seperate Bearing Bracket	075
SDS / SDS-V		Horizontal / Vertical Double Suction Centrifugal Pumps	079
SKM		Horizontal Multistage Centrifugal Pumps	085
SKM-E		Horizontal Multistage Centrifugal Pumps (End Suction)	093
SKMV-H		Vertical Multistage Centrifugal Pumps	099
C		Submersible Sewage Pumps	105
PC / PC-VM		Waste Water and Process Pumps (Horizontal / Vertical)	117
PC-V		Waste Water and Process Pumps (Sump Design)	123
SKM-EVK		Multistage Process Pump (Sump Design)	127
SMV		Vertical Line Shaft	131
NMT / NMTD		In-line Wet Rotor Circulation Pumps	135
HYDROPOWER		Pump as Turbine	141
BOOSTERS			145
TH CDLF		Stainless Steel Full Automatic Booster Set	155
TH SB		Norly Material Full Automatic Booster Set	165
TH SKMV		Cast Casing Full Automatic Booster Set	171
TH GRV-VD / VB		Cast Casing Full Automatic Booster Set	175
FIRE PUMPS			
SNT / SDS / SNL / SKM		Fire Pumps and Groups Conforming to NFPA 20	179
SDS / SNK		UL Listed / FM Approved Fire Pumps	191



Pump • Fire Fighting Units • Booster Set



kalasanati.com

Training, Selecting, Purchasing

PUMPS



Pump • Fire Fighting Units • Booster Set

ECO SNT

EN 733 NORM PUMPS



Kalasanati.com



Handled Liquids

Clean or slightly contaminated low viscosity liquids without solid & fibrous particles.

Technical Data

Discharge Flange _____ DN 32.....DN 150 mm

Capacity _____ up to 600 m³/h(*)

Head _____ up to 100 m(*)

Speed _____ up to 3000 rpm

Design Temperature _____ -10 °C' to +140 °C(**)

Casing Pressure (Pmax) _____ 10 bar (16 bar)(**)

(Pmax: Suction Pressure + Shut off Head)

(*) Contact company for higher capacity and head values.

(**) The Material of pump differs according to the type of pumped liquid, operating temperature and pressure. Contact for detailed information.

Design Features

•Horizontal , radially split volute casing type , single stage, end suction centrifugal pump with closed impeller.

•Dimensionally complies with EN 733.

•Complies EU547/2012 regulations.

•In addition to 29 basic sizes conforming with EN 733, there are 9 additional sizes. Dimensions of additional sizes may differ from other suppliers.

Pump Designation

Pump Type _____

Discharge Nozzle (DN-mm) _____

Nominal Impeller Diameter (mm) _____

Special Application _____

•ECO SNT 40-315, 50-315, 65-315, 80-315, 100-315, 125-250 pumps are given with 3000 rpm only for fire fighting application.

•Suction and discharge flanges conform to EN 1092-2 / PN 16. (EN 1092-1/PN16 for steel or stainless steel casing). In case of request, ANSI/ASME flanges can be supplied.

•Due to the back-pull-out design, the complete bearing assembly including impeller and casing cover can be dismantled without removing the volute casing from the piping system. (With spacer coupling application, also possible to take out the rotor group without dismantling the electric motor.)

•All impellers are balanced dynamically or statically according to ISO 1940 grade 6.3.

•Axial thrust is balanced by impeller balancing holes system.

•Direction of rotation is clockwise viewed from drive end.

•In case of request, wear ring and/or shaft sleeve can be supplied.

•Bearings of ECO SNT type pumps are normally "life time grease lubricated" ball bearings. If there is a demand, oil lubrication or re-greasable bearing can be supplied.

•For ECO SNT drawings, please look at below adress www.standartpompa.com.

Shaft Sealing

•In standard production, soft packed stuffing boxes are used.

•Depending on customer request, mechanical seals are available. In this case, pump shaft is always stainless steel.

ECO SNT 100 - 250 - XXX

02.2020 / Rev. 3



Field Chart

ECO SNT

Kalasanati.com

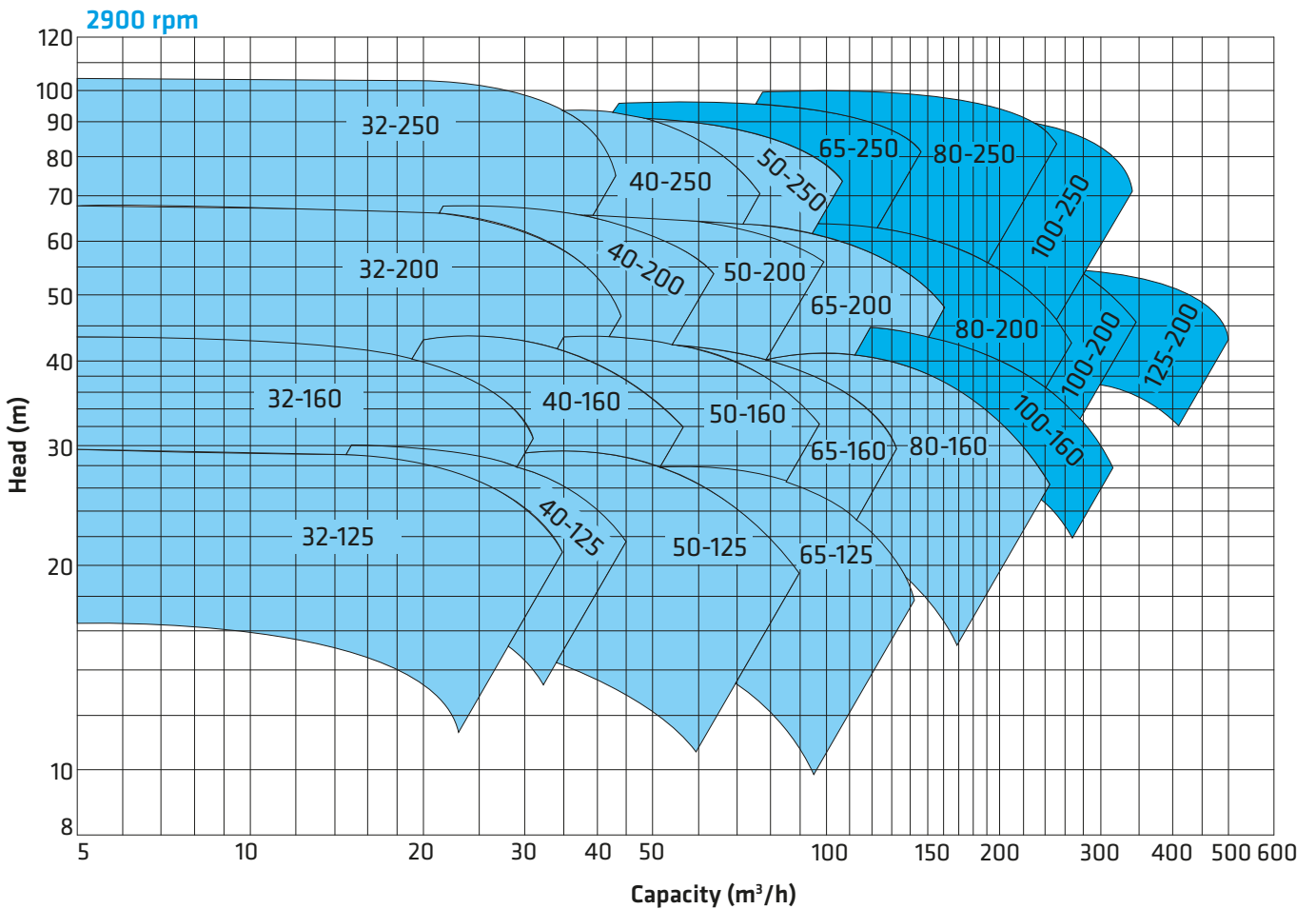
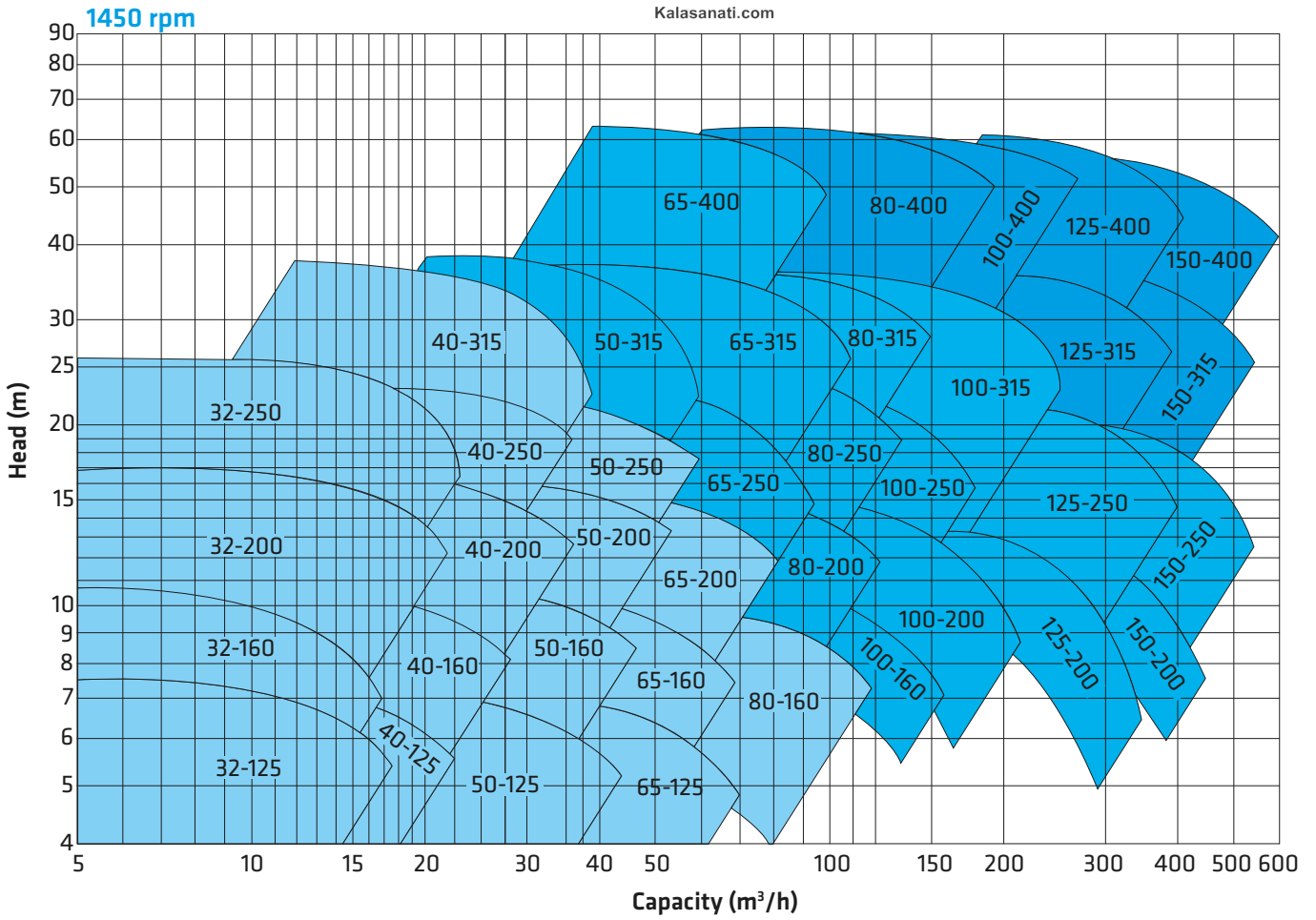

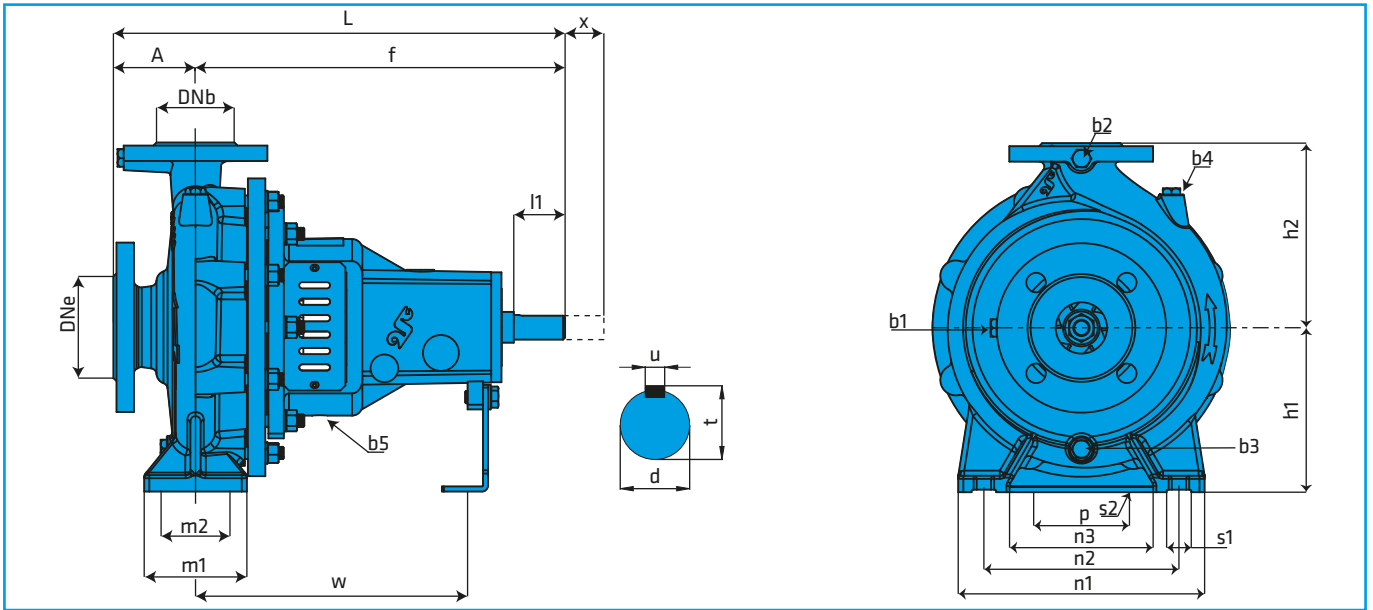

Pump Type		Form	Overall Dimensions								Foot Dimensions								Shaft End				Support Connections					Weight	Space
EN 733	Other		DNe	DNb	A	f	L	h1	h2	m1	m2	n1	n2	n3	s1	p	s2	w	d	l1	t	u	b1	b2	b3	b4	b5	(kg)	x**
32-125		F1	50	32	80	360	440	112	140	100	70	190	140	90	14	110	14	260	24	50	27	8	1/4"	1/4"	1/4"	1/4"	3/8"	32	100
32-160		F1	50	32	80	360	440	132	160	100	70	240	190	140	14	110	14	260	24	50	27	8	1/4"	1/4"	1/4"	1/4"	3/8"	39	100
32-200		F2	50	32	80	360	440	160	180	100	70	240	190	140	14	110	14	260	24	50	27	8	1/4"	1/4"	1/4"	1/4"	3/8"	41	100
	32-250	F2	50	32	100	360	460	180	225	125	95	320	250	190	14	110	14	260	24	50	27	8	1/4"	1/4"	1/4"	1/4"	3/8"	53	100
40-125		F1	65	40	80	360	440	112	140	100	70	210	160	110	14	110	14	260	24	50	27	8	1/4"	1/4"	1/4"	1/4"	3/8"	33	100
40-160		F1	65	40	80	360	440	132	160	100	70	240	190	140	14	110	14	260	24	50	27	8	1/4"	1/4"	1/4"	1/4"	3/8"	40	100
40-200		F2	65	40	100	360	460	160	180	100	70	265	212	165	14	110	14	260	24	50	27	8	1/4"	1/4"	1/4"	1/4"	3/8"	45	100
40-250		F2	65	40	100	360	460	180	225	125	95	320	250	190	14	110	14	260	24	50	27	8	1/4"	1/4"	1/4"	1/4"	3/8"	57	100
	40-315	F2	65	40	100	360	460	200	250	125	95	345	280	190	14	110	14	260	24	50	27	8	1/4"	1/4"	1/4"	1/4"	3/8"	67	100
50-125		F1	65	50	100	360	460	132	160	100	70	240	190	140	14	110	14	260	24	50	27	8	1/4"	1/4"	1/4"	1/4"	3/8"	34	100
50-160		F1	65	50	100	360	460	160	180	100	70	265	212	165	14	110	14	260	24	50	27	8	1/4"	1/4"	1/4"	1/4"	3/8"	42	100
50-200		F2	65	50	100	360	460	160	200	100	70	265	212	165	14	110	14	260	24	50	27	8	1/4"	1/4"	1/4"	1/4"	3/8"	48	100
50-250		F2	65	50	100	360	460	180	225	125	95	320	250	190	14	110	14	260	24	50	27	8	1/4"	1/4"	1/4"	1/4"	3/8"	57	100
	50-315	F2	65	50	125	470	595	225	280	125	95	345	280	190	19	110	14	340	32	80	35	10	1/4"	1/4"	1/4"	1/4"	3/8"	90	100
65-125		F1	80	65	100	360	460	160	180	125	95	280	212	150	14	110	14	260	24	50	27	8	1/4"	1/4"	3/8"	3/8"	3/8"	40	100
65-160		F1	80	65	100	360	460	160	200	125	95	280	212	150	14	110	14	260	24	50	27	8	1/4"	1/4"	3/8"	3/8"	3/8"	46	100
65-200		F2	80	65	100	360	460	180	225	125	95	320	250	190	14	110	14	260	24	50	27	8	1/4"	1/4"	3/8"	3/8"	3/8"	51	140
65-250		F2	80	65	100	470	570	200	250	160	120	360	280	200	19	110	14	340	32	80	35	10	1/4"	1/4"	3/8"	3/8"	3/8"	90	140
65-315		F2	80	65	125	470	595	225	280	160	120	400	315	240	19	110	14	340	32	80	35	10	1/4"	1/4"	3/8"	3/8"	3/8"	105	140
	65-400	F2	100	65	125	470	595	260	355	160	120	435	355	275	19	110	14	340	32	80	35	10	1/4"	1/4"	3/8"	3/8"	3/8"	130	140
80-160		F1	100	80	125	360	485	180	225	125	95	320	250	190	14	110	14	260	24	50	27	8	1/4"	1/4"	3/8"	3/8"	3/8"	49	140
80-200		F1	100	80	125	470	595	180	250	125	95	345	280	215	14	110	14	340	32	80	35	10	1/4"	1/4"	3/8"	3/8"	3/8"	63	140
80-250		F2	100	80	125	470	595	200	280	160	120	400	315	240	19	110	14	340	32	80	35	10	1/4"	1/4"	3/8"	3/8"	3/8"	95	140
80-315		F2	100	80	125	470	595	250	315	160	120	400	315	240	19	110	14	340	32	80	35	10	1/4"	1/4"	3/8"	3/8"	3/8"	125	140
	80-400	F2	100	80	125	530	655	280	355	160	120	435	355	275	19	110	14	360	42	110	45	12	1/4"	1/4"	3/8"	3/8"	3/8"	175	140
	100-160	F1	125	100	125	470	595	200	280	160	120	360	280	200	19	110	14	340	32	80	35	10	1/4"	1/4"	3/8"	3/8"	3/8"	80	140
100-200		F1	125	100	125	470	595	200	280	160	120	360	280	200	19	110	14	340	32	80	35	10	1/4"	1/4"	3/8"	3/8"	3/8"	87	140
100-250		F2	125	100	140	470	610	225	280	160	120	400	315	240	19	110	14	340	32	80	35	10	1/4"	1/4"	3/8"	3/8"	3/8"	100	140
100-315		F2	125	100	140	470	610	250	315	160	120	400	315	240	19	110	14	340	32	80	35	10	1/4"	1/4"	3/8"	3/8"	3/8"	130	140
100-400		F2	125	100	140	530	670	280	355	200	150	500	400	300	23	110	14	360	42	110	45	12	1/4"	1/4"	3/8"	3/8"	3/8"	180	140
	125-200	F1	150	125	140	470	610	250	315	160	120	400	315	240	19	110	14	340	32	80	35	10	1/4"	1/4"	1/2"	1/2"	3/8"	97	140
125-250		F2	150	125	140	470	610	250	355	160	120	400	315	240	19	110	14	340	32	80	35	10	1/4"	1/4"	1/2"	1/2"	3/8"	110	140
125-315		F1	150	125	140	530	670	280	355	200	150	500	400	300	23	110	14	360	42	110	45	12	1/4"	1/4"	1/2"	1/2"	3/8"	180	140
125-400		F2	150	125	140	530	670	315	400	200	150	500	400	300	23	110	14	360	42	110	45	12	1/4"	1/4"	1/2"	1/2"	3/8"	200	140
	150-200	F1	200	150	160	470	630	280	355	200	150	500	400	300	23	110	14	340	32	80	35	10	1/4"	1/4"	1/2"	1/2"	3/8"	150	140
	150-250	F2	200	150	160	470	630	280	375	200	150	500	400	300	23	110	14	340	32	80	35	10	1/4"	1/4"	1/2"	1/2"	3/8"	160	140
150-315		F1	200	150	160	530	690	280	400	200	150	550	450	350	23	110	14	360	42	110	45	12	1/4"	1/4"	1/2"	1/2"	3/8"	190	140
150-400		F2	200	150	160	530	690	315	450	200	150	550	450	350	23	110	14	360	42	110	45	12	1/4"	1/4"	1/2"	1/2"	3/8"	230	140

(**) Gap necessary for the withdrawal of the pump rotor from the driven end without the need for dismantling the motor and pipework (spacer coupling application)



Assembly Drawings

ECO SNT

Kalasanati.com

Form: F1 (Soft Packing Seal Pump)

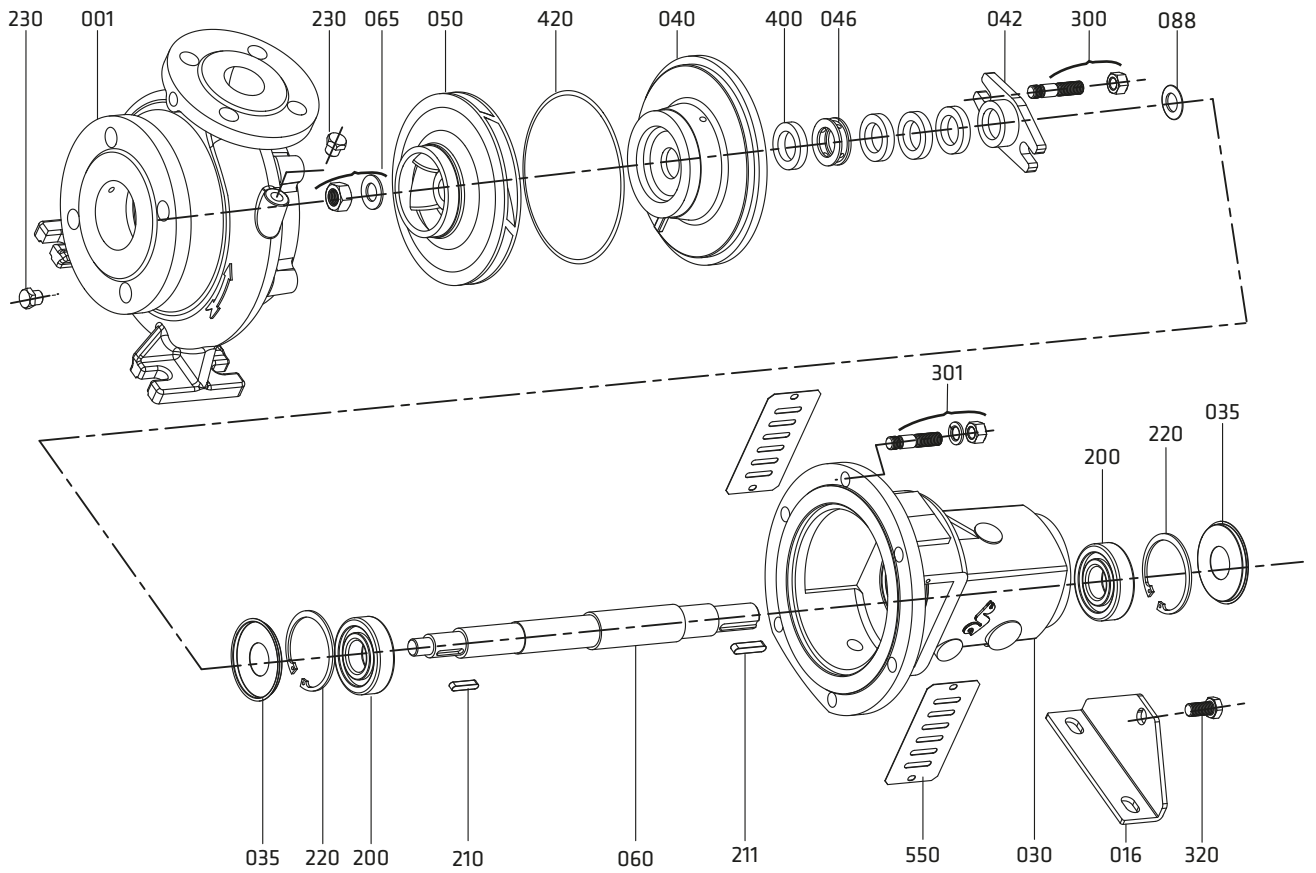

Form: F2 (Soft Packing Seal Pump)

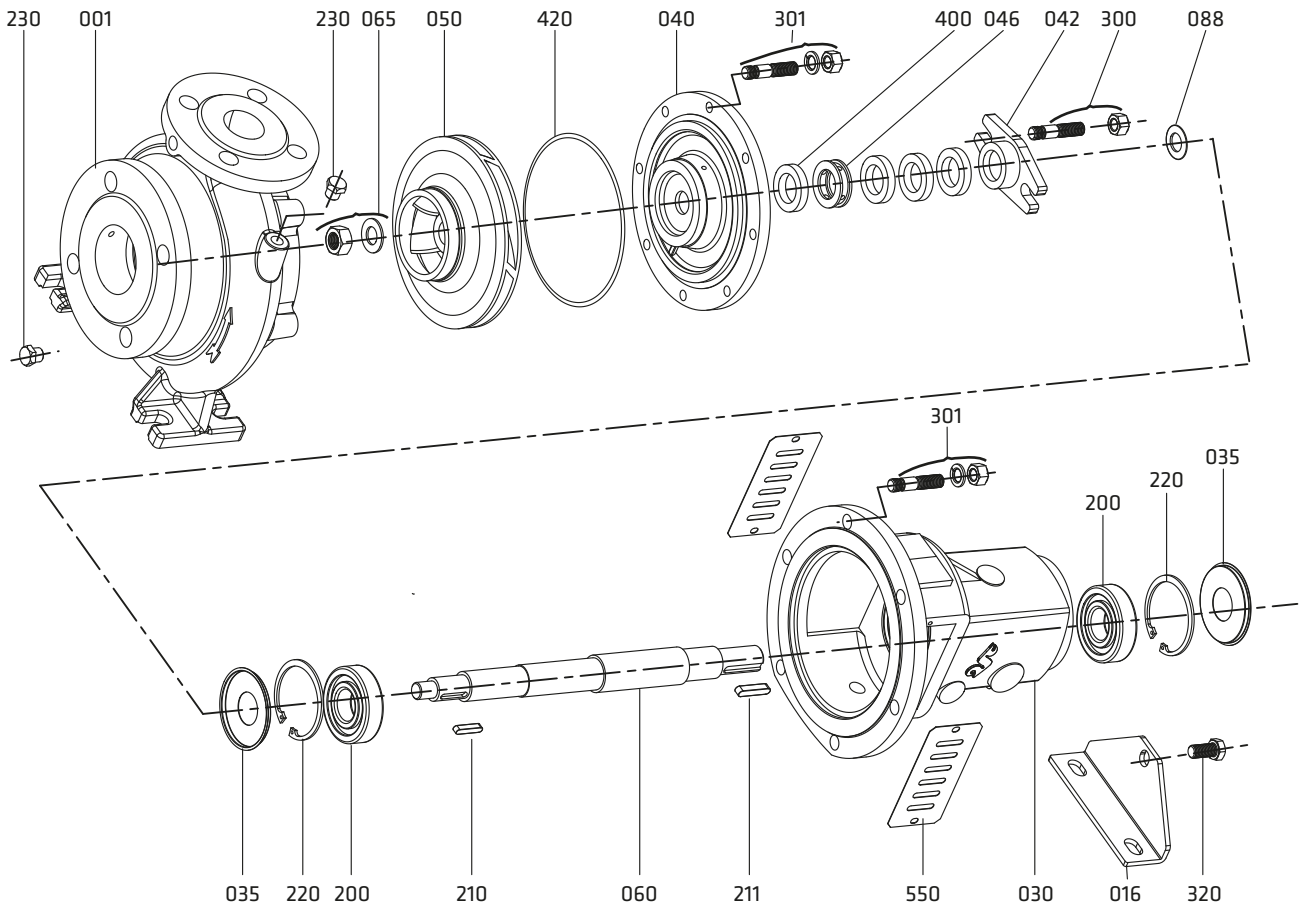



Kalasanati.com

ECO SNT

Assembly Drawings

Form: F1 (Mechanical Seal Pump)

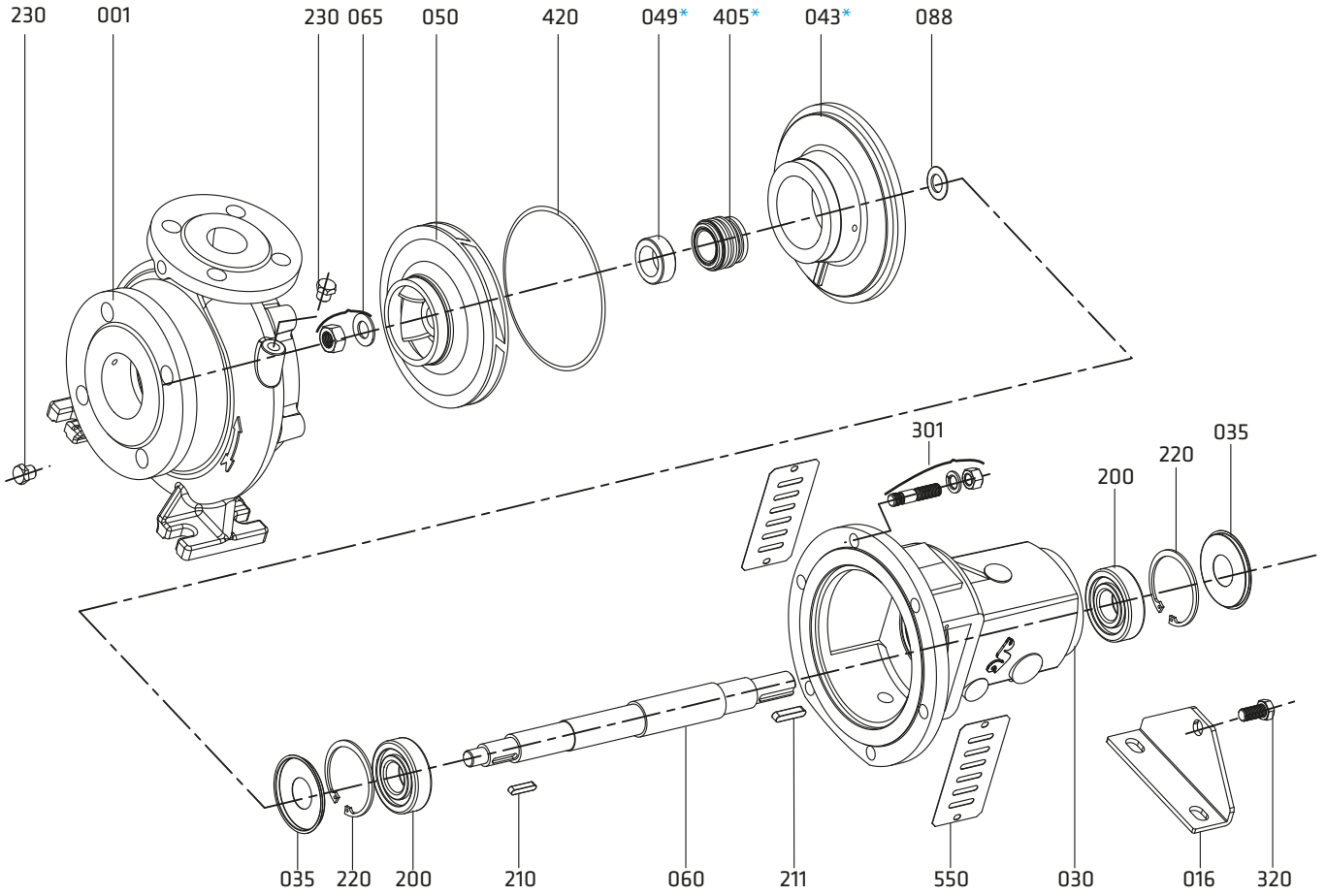

Form: F2 (Mechanical Seal Pump)

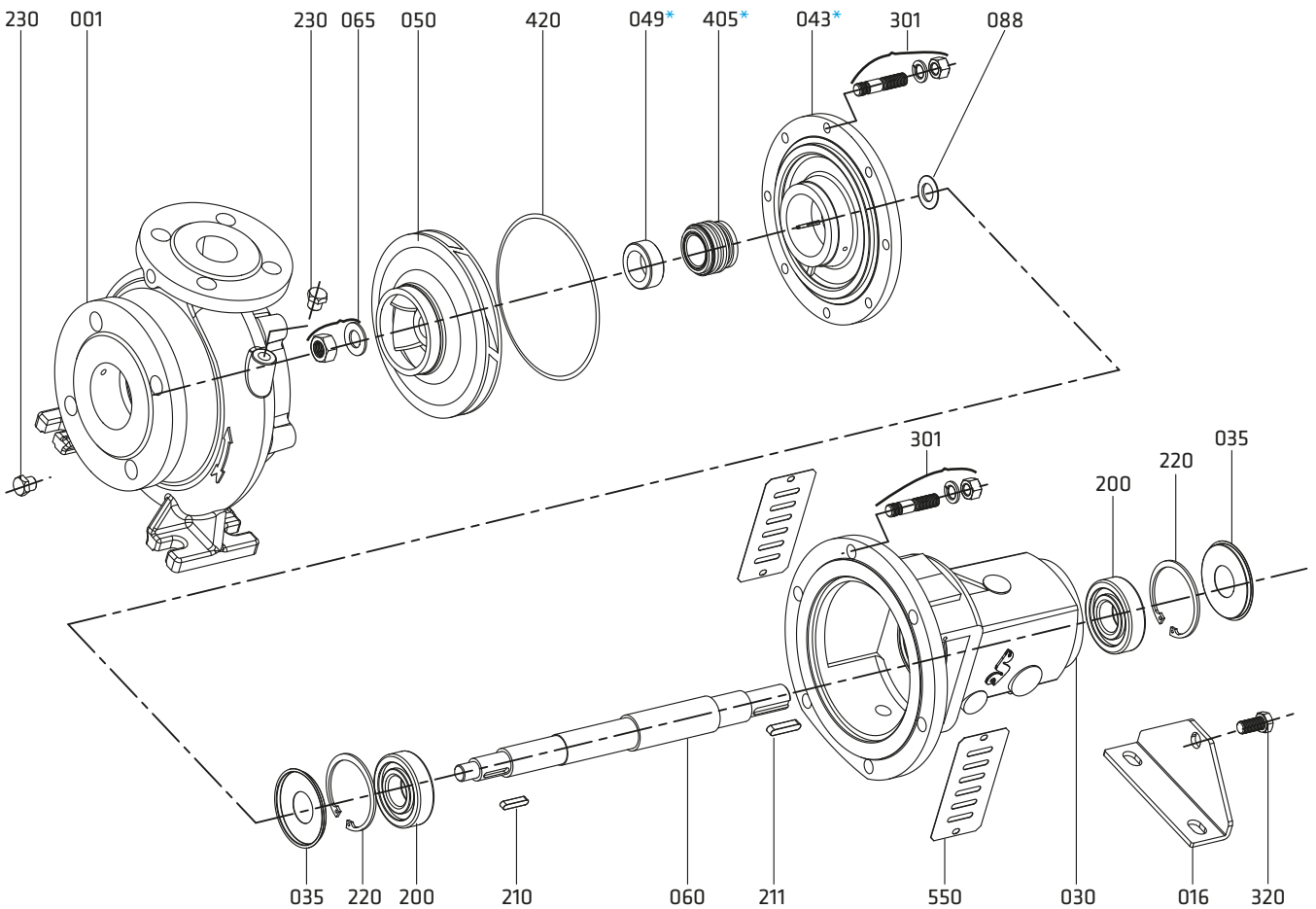



Kalasanati.com

ECO SNT

Assembly Drawings

Oil Lubrication Bearing Housing

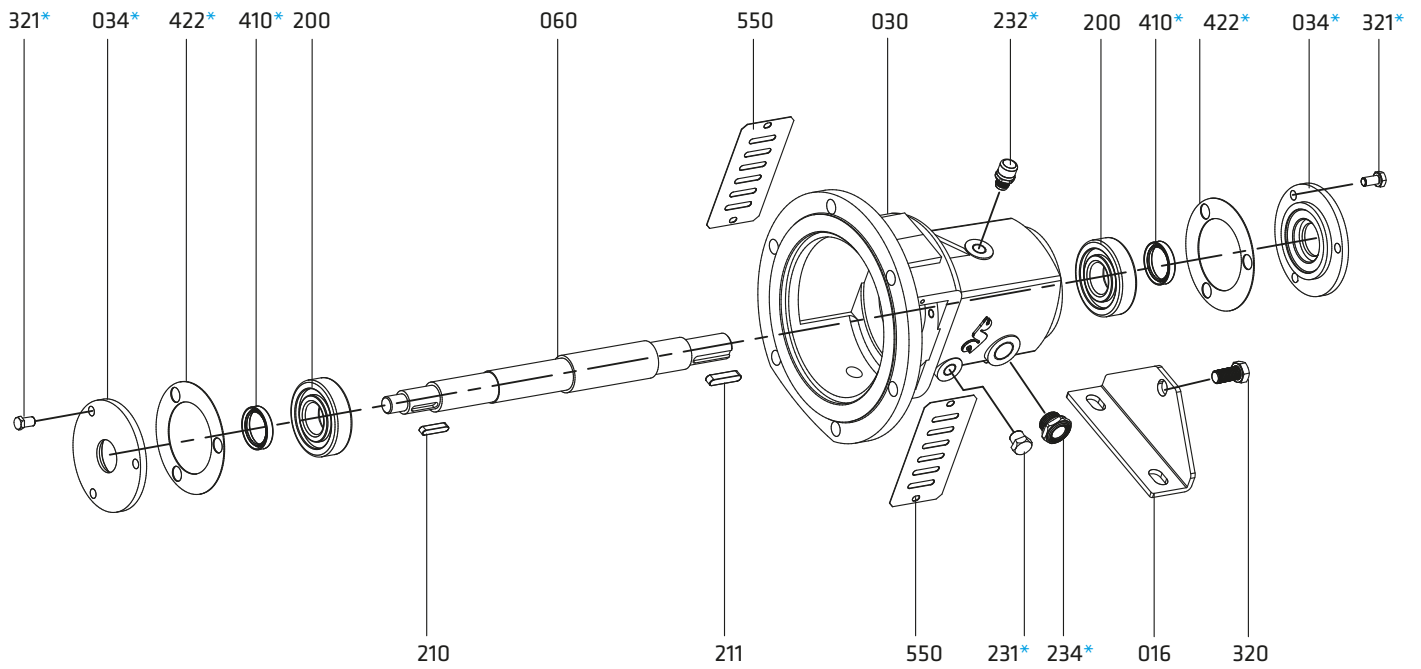

Re-greasable Bearing Housing

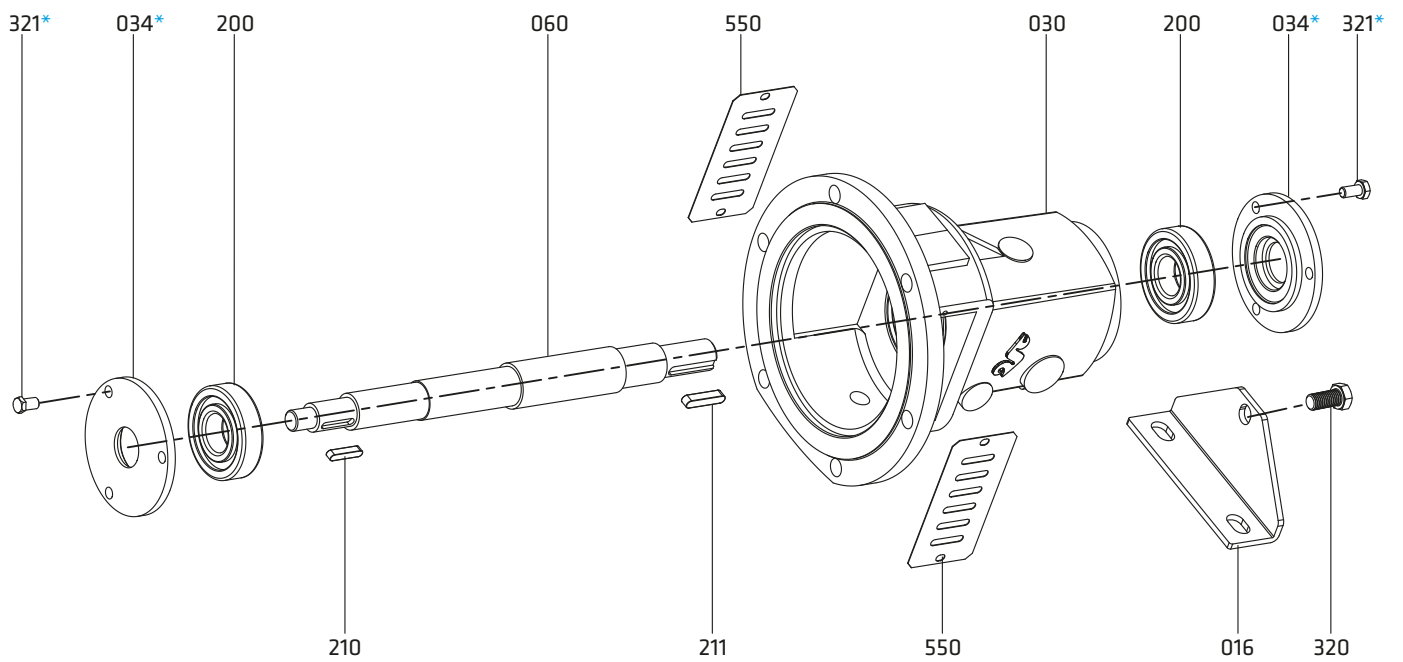

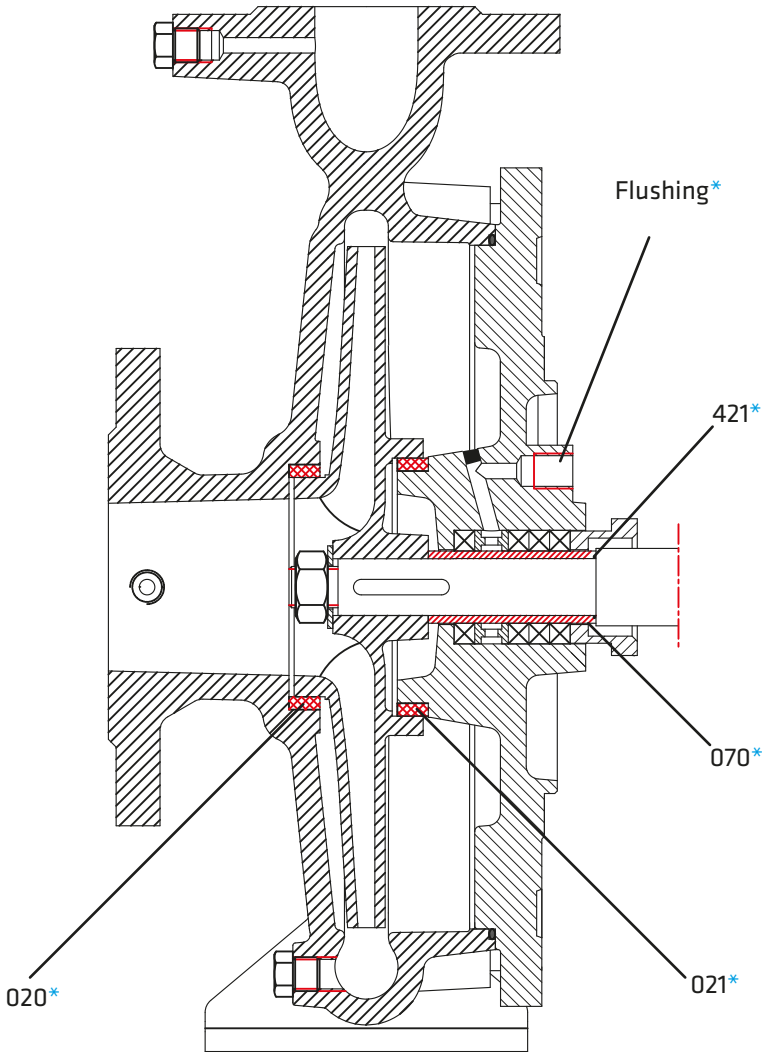

Part List

001	Volute Casing
016	Support Foot
020*	Wear Ring (Casing)
021*	Wear Ring (Seal Cover)
030	Bearing Housing
034*	Bearing Cover (GG)
035	Bearing Cover (St)
040	Soft Packing Seal Cover
042	Gland
043*	Mechanical Seal Cover
046	Lantern Ring
049*	Mechanical Seal Spacer Sleeve
050	Impeller
060	Shaft
065	Impeller Nut and Washer
070*	Shaft Sleeve
088	Thrower
200	Ball Bearing
210	Impeller Key
211	Coupling Key
220	Circlip
230	Screw
231*	Screw
232*	Oil Filling Plug and Breather
234*	Oil Level Indicator
300	Gland Stud and Nut
301	Stud, Washer and Nut
320	Screw
321*	Screw
400	Soft Packing
405*	Mechanical Seal
410*	Lip Seal
420	O-ring
421*	O-ring
422*	Gasket
550	Guard

(*) Optional



Technical Data

ECO SNT

Part List	10	30	35	20	60	6L	70	7L	8M	7D	75	8N	80	4C	4A	40	20	80	8T	60	7L	7E	7D	
	0.6025	0.7040	0.7043	1.0619	1.4308	1.4309	1.4408	1.4409	1.4500	1.4517	1.4469	1.4317	1.4008	2.1050.01	2.0975.01	2.1096.01	1.0503	1.4021	1.4021+QT	1.4301	1.4404	1.4460	1.4462	
Volute Casing	●	○	○	○	○	○	○	○	○	○	○	○	○	○	○	○	○	○	○	○	○	○	○	○
Seal Cover (Mech. or Soft)	●	○	○	○	○	○	○	○	○	○	○	○	○	○	○	○	○	○	○	○	○	○	○	○
Impeller	●	○	○	○	○	○	○	○	○	○	○	○	○	○	○	○	○	○	○	○	○	○	○	○
Shaft																	●	○	○	○	○	○	○	○
Bearing House	●	○	○	○	○	○	○	○	○	○	○	○	○	○	○	○	○	○	○	○	○	○	○	○
Wear Ring	○	○	○	○	○	○	○	○	○	○	○	○	○	○	○	○	○	○	○	○	○	○	○	○
Shaft Sleeve																	○	○	○	○	○	○	○	○
Mechanical Seal (*)	EN 12756																							

(*) Optional :Depending on customer requirement or request different types and brands of mechanical seals are applicable.

● Standard manufacturing
○ Optional

NOTE: Depends on the request, different than above casting and shaft material can be supplied.

Material Equivalents

Description	DIN / EN		AISI / SAE / ASTM
Cast Iron	0.6025	EN-GJL-250 (GG25)	A48 Class 40B
Nodular Cast Iron	0.7040	EN-GJS-400-15 (GGG40)	A536 60-40-18
Nodular Cast Iron	0.7043	EN-GJS-400-18-LT (GGG40.3)	A536 60-40-18
Cast Steel	1.0619	GP240GHGS-C25	A216 WCB
Chrome Nickel Cast Steel	1.4308	GX5CrNi19-10	A351 CF8
Chrome Nickel Cast Steel (low carbon)	1.4309	GX2CrNi19-11	A351 CF3
Chrome Nickel Molybdenum Cast Steel	1.4408	GX5CrNiMo19-11-2	A351 CF8M
Chrome Nickel Molybdenum Cast Steel (low carbon)	1.4409	GX2CrNiMo19-11-2	A351 CF3M
Austenitic Cast Steel	1.4500	GX7NiCrMoCuNb25-20	A351 CN7M
Austenitic - Ferritic Cast Steel (duplex)	1.4517	GX2CrNiMoCuN25-6-3-3	A890 CD4MCuN
Austenitic - Ferritic Cast Steel (super duplex)	1.4469	GX2CrNiMoN26-7-4	A890 CE3MN
Martenzitic Stainless Cast Steel	1.4317	GX4CrNi13-4	A352 CA6NM
Martenzitic Stainless Cast Steel	1.4008	GX7CrNiMo12-1	A217 CA15
Cast Bronze (tin alloy)	2.1050.01	G-CuSn10	B427 C90700
Cast Bronze (nickel alloy)	2.0975.01	G-CuAl10Ni	B148 C95500
Cast Bronze (Leaded)	2.1096.01	G-CuSn5ZnPb	B584 C83600
Carbon Steel	1.0503	C45	AISI 1045
Chrome Steel	1.4021	X20Cr13	A276 Type 420
Chrome Steel (Heat treated)	1.4021	X20Cr13	A276 Type 420+QT
Chrome Nickel Steel	1.4301	X5CrNi18-10	A276 Type 304
Chrome Nickel Steel (low carbon)	1.4404	X2CrNiMo17-12-2	A276 Type 316L
Duplex (austenitic-ferritic) Steel	1.4460	X3CrNiMoN27-5-2	AISI 329
Duplex (austenitic-ferritic) Steel	1.4462	X2CrNiMoN22-5-3	UNS S32205

Flange Dimensions

DNe/DNb	Suction & Discharge (PN 16)			
	Df	k	s	n
32	140	100	19	4
40	150	110	19	4
50	165	125	19	4
65	185	145	19	4
80	200	160	19	8
100	220	180	19	8
125	250	210	19	8
150	285	240	23	8
200	340	295	23	12

" n " number of holes

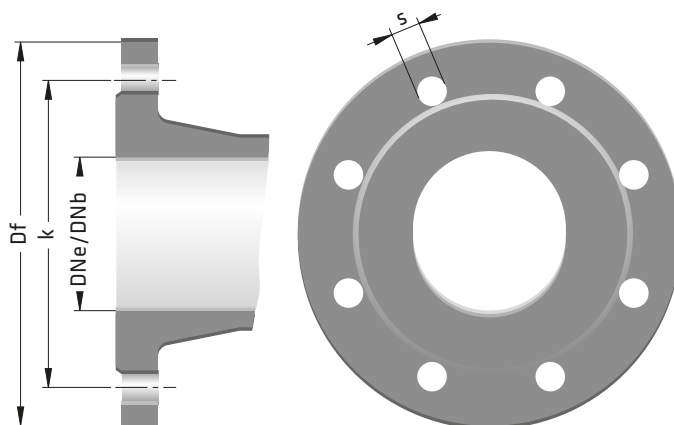



Pump • Fire Fighting Units • Booster Set

ECO SNM RIGIDLY COUPLED CENTRIFUGAL PUMPS



Kalasanati.com



Handled Liquids

Clean or slightly contaminated low viscosity liquids without solid & fibrous particles.

Technical Data

Discharge Flange _____ DN 32.....DN 150 mm

Capacity _____ up to 600 m³/h(*)

Head _____ up to 100 m(*)

Speed _____ up to 3000 rpm

Design Temperature _____ -10 °C' to +140 °C(**)

Casing Pressure (Pmax) _____ 10 bar (16 bar)(**)

(Pmax: Suction Pressure + Shut off Head)

(*) Contact company for higher capacity and head values.

(**) The Material of pump differs according to the type of pumped liquid, operating temperature and pressure. Contact for detailed information.

Design Features

•Horizontal / Vertical rigidly-coupled, volute casing, single stage, end suction centrifugal pump with closed impeller.

•Volute casing dimensions comply with EN 733.

•Complies EU547/2012 regulations.

•Suction and discharge flanges conform to EN 1092-2 / PN 16. The flanges are according to EN 1092-1 / PN 16 for steel or stainless steel casing. In case of request, ANSI/ASME flanges can be supplied.

Pump Designation

Pump Type _____

Vertical _____

Discharge Nozzle (DN-mm) _____

Nominal Impeller Diameter (mm) _____

Special Application _____

ECO SNM-V 100 - 250 - XXX

•Pumps are rigidly coupled with electric motors of IEC frame sizes with high efficiency class.

•All impellers are balanced dynamically or statically according to ISO 1940 grade 6.3.

•Axial thrust is balanced by impeller balancing holes system.

•Direction of rotation is clockwise viewed from drive end.

•In case of request, wear ring and/or shaft sleeve can be supplied.

•The pump and motor have separate shafts connected by a rigid coupling or through slide fit shaft. Axial and radial forces are absorbed by electric motor bearings.

•Rigidly coupled pumps are lighter and smaller comparing to the norm centrifugal pumps of same hydraulic specifications.

•When the elbow is mounted on the suction of the pump, the name is changed to ECO SNM-V. In this case, the pump is always installed vertically.

•The electrical motor powers of ECO SNM-V pumps are limited because of its installation type.

•For ECO SNM and ECO SNM-V drawings, please look at below address www.standartpompa.com.

Shaft Sealing

•Depending on customer request or liquid type, mechanical seals are available.



1450 rpm

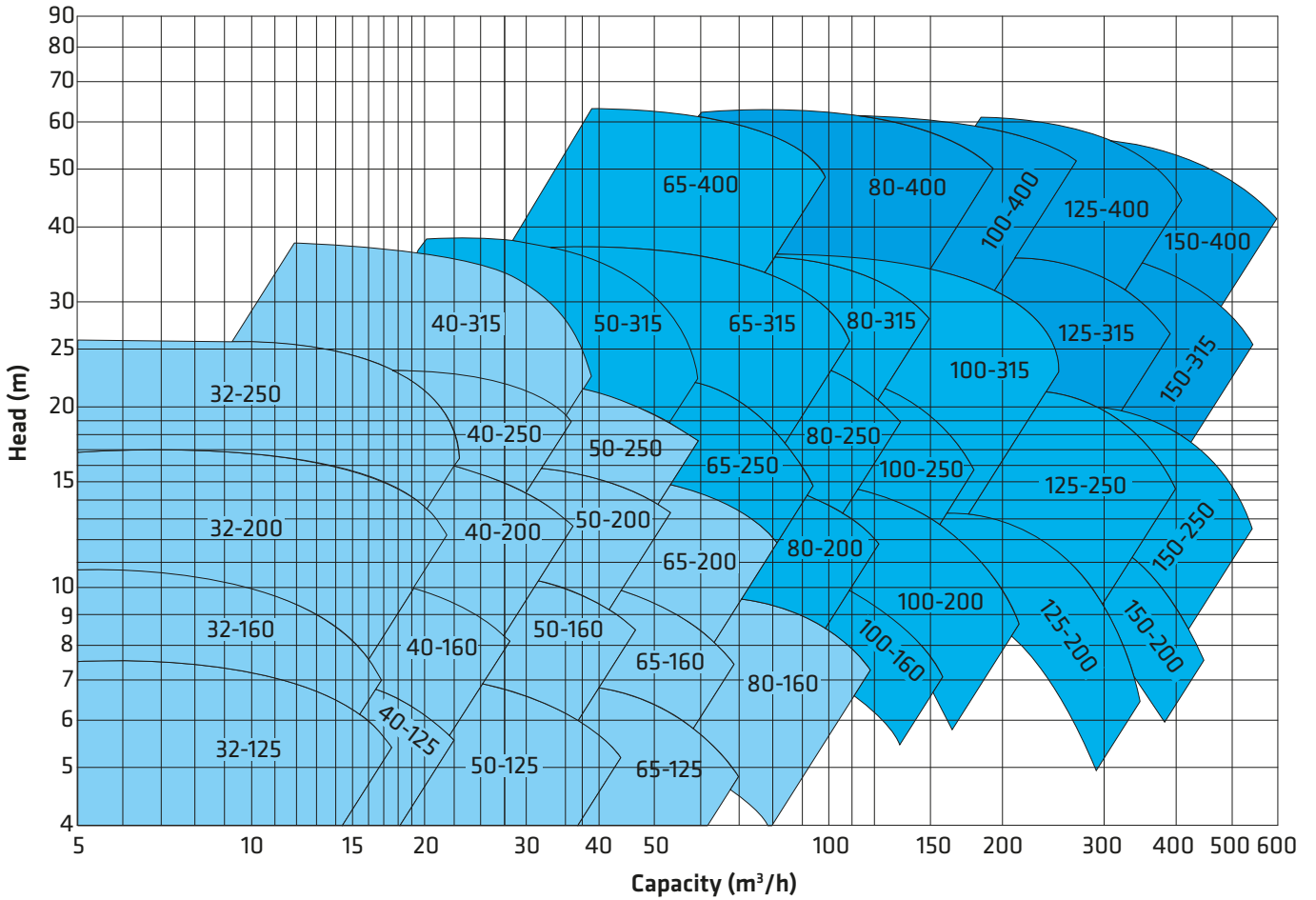

2900 rpm

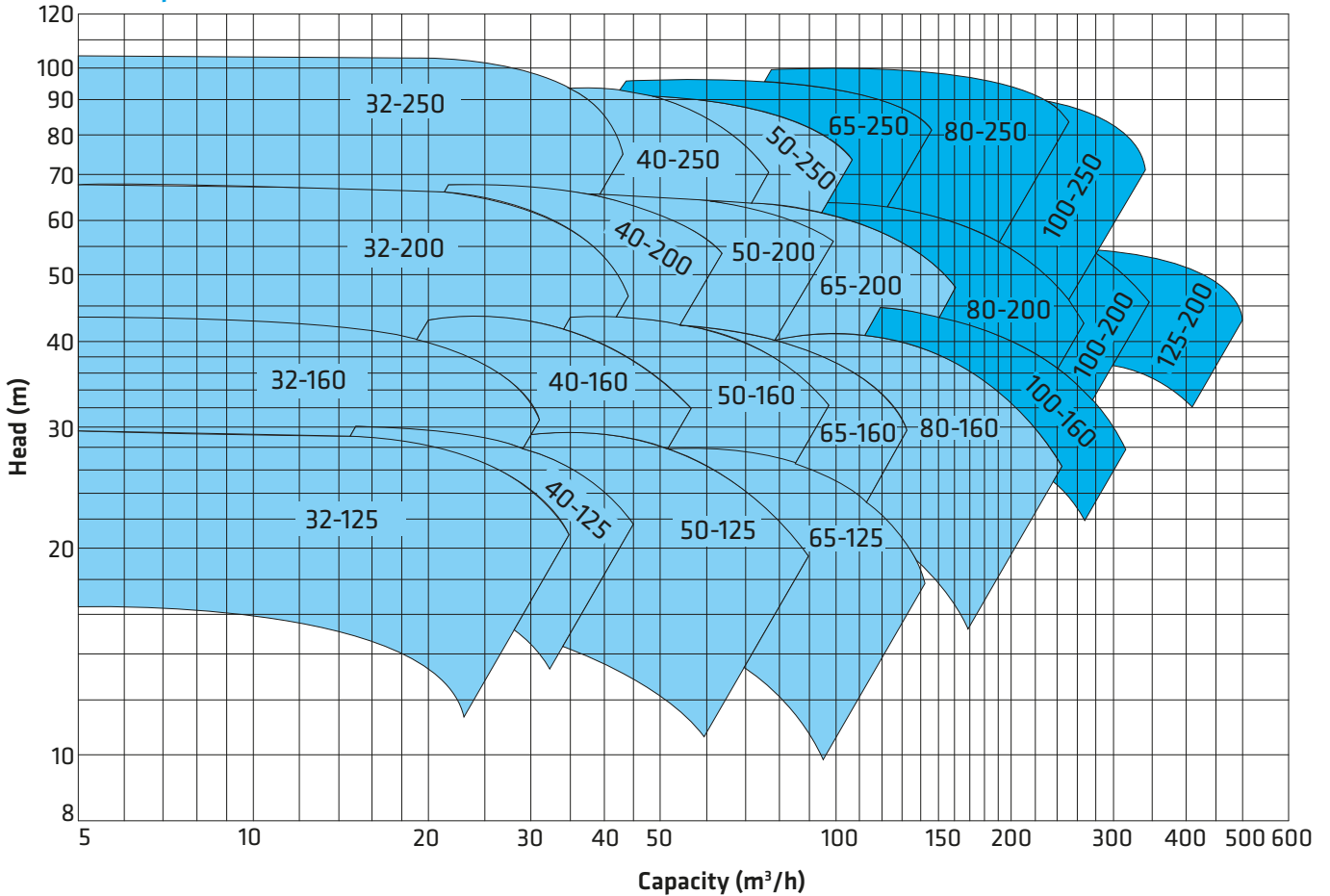

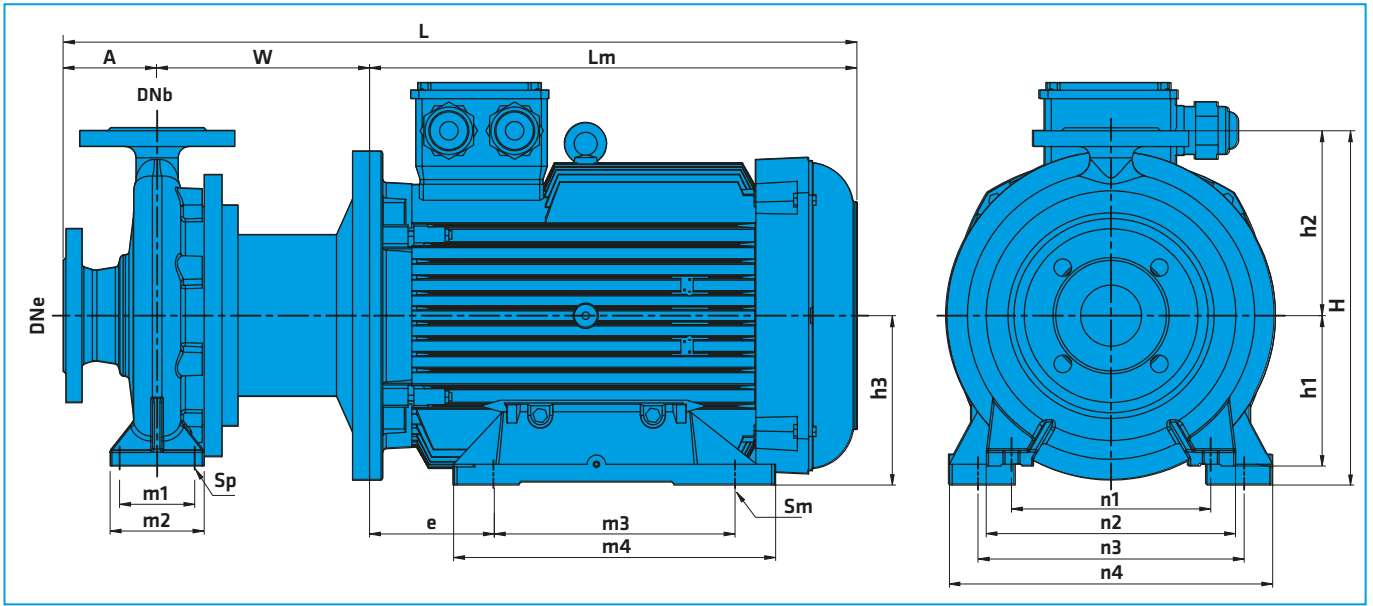

2900 rpm (2 Pole Motor)

FORM	Pump Type	MOTOR		ECO SNM INSTALLATION DIMENSIONS (mm)																				
				Overall Dimensions											Foot Dimensions									
				kW	IEC	DNe	DNb	A	W	Lm	L	H	h1	h2	h3	e	m1	m2	m3	m4	n1	n2	n3	n4
F1	32-125	1,5	90L	50	32	80	156	266	503	252	112	140	90	56	70	100	125	158	140	190	140	190	14	10
F1	32-125	2,2	90L	50	32	80	156	266	503	252	112	140	90	56	70	100	125	158	140	190	140	190	14	10
F1	32-125	3	100L	50	32	80	179	292	551	252	112	140	100	63	70	100	140	178	140	190	160	192	14	12
F1	32-125	4	112M	50	32	80	179	336	595	252	112	140	112	70	70	100	140	176	140	190	190	220	14	12
F1	32-160	2,2	90L	50	32	80	156	267	503	292	132	160	90	56	70	100	125	158	190	240	140	190	14	10
F1	32-160	3	100L	50	32	80	179	292	551	292	132	160	100	63	70	100	140	178	190	240	160	192	14	12
F1	32-160	4	112M	50	32	80	179	336	595	292	132	160	112	70	70	100	140	176	190	240	190	220	14	12
F1	32-160	5,5	132S	50	32	80	189	360	629	292	132	160	132	89	70	100	140	180	190	240	216	252	14	12
F2	32-200	5,5	132S	50	32	80	189	360	629	340	160	180	132	89	70	100	140	180	190	240	216	252	14	12
F2	32-200	7,5	132M	50	32	80	189	396	665	340	160	180	132	89	70	100	178	218	190	240	216	252	14	12
F2	32-200	11	160M	50	32	80	226	466	772	340	160	180	160	108	70	100	210	311	190	240	254	298	14	15
F2	32-250	7,5	132M	50	32	100	189	396	685	405	180	225	132	89	95	125	178	218	250	320	216	252	14	12
F2	32-250	11	160M	50	32	100	226	466	792	405	180	225	160	108	95	125	210	311	250	320	254	298	14	15
F2	32-250	15	160M	50	32	100	226	466	792	405	180	225	160	108	95	125	210	311	250	320	254	298	14	15
F2	32-250	18,5	160M	50	32	100	226	466	792	405	180	225	160	108	95	125	210	311	250	320	254	298	14	15
F2	32-250	22	180M	50	32	100	226	519	845	405	180	225	180	121	95	125	241	343	250	320	279	344	14	15
F1	40-125	2,2	90L	65	40	80	156	267	503	252	112	140	90	56	70	100	125	158	160	210	140	190	14	10
F1	40-125	3	100L	65	40	80	179	292	551	252	112	140	100	63	70	100	140	178	160	210	160	192	14	12
F1	40-125	4	112M	65	40	80	179	335	594	252	112	140	112	70	70	100	140	176	160	210	190	220	14	12
F1	40-125	5,5	132S	65	40	80	189	360	629	252	112	140	132	89	70	100	140	180	160	210	216	252	14	12
F1	40-160	4	112M	65	40	80	179	336	595	292	132	160	112	70	70	100	140	176	190	240	190	220	14	12
F1	40-160	5,5	132S	65	40	80	189	361	629	292	132	160	132	89	70	100	140	180	190	240	216	252	14	12
F1	40-160	7,5	132M	65	40	80	189	396	665	292	132	160	132	89	70	100	178	218	190	240	216	252	14	12
F2	40-200	7,5	132M	65	40	100	189	396	685	340	160	180	132	89	70	100	178	218	212	265	216	252	14	12
F2	40-200	11	160M	65	40	100	226	466	792	340	160	180	160	108	70	100	210	311	212	265	254	298	14	15
F2	40-200	15	160M	65	40	100	226	466	792	340	160	180	160	108	70	100	210	311	212	265	254	298	14	15
F2	40-200	18,5	160M	65	40	100	226	466	792	340	160	180	160	108	70	100	210	311	212	265	254	298	14	15
F2	40-250	15	160L	65	40	100	226	466	792	405	180	225	160	108	70	125	210	311	250	320	254	298	14	15
F2	40-250	18,5	160L	65	40	100	226	466	792	405	180	225	160	108	70	125	210	311	250	320	254	298	14	15
F2	40-250	22	180M	65	40	100	226	519	845	405	180	225	180	121	70	125	241	343	250	320	279	344	14	15
F2	40-250	30	200L	65	40	100	226	555	881	425	180	225	200	133	70	125	305	365	250	320	318	388	14	19
F1	50-125	3	100L	65	50	100	179	292	571	292	132	160	100	63	70	100	140	178	190	240	160	192	14	12
F1	50-125	4	112M	65	50	100	179	336	615	292	132	160	112	70	70	100	140	176	190	240	190	220	14	12
F1	50-125	5,5	132S	65	50	100	189	361	650	292	132	160	132	89	70	100	140	180	190	240	216	252	14	12
F1	50-125	7,5	132M	65	50	100	189	396	685	292	132	160	132	89	70	100	178	218	190	240	216	252	14	12
F1	50-160	5,5	132S	65	50	100	189	360	649	340	160	180	132	89	70	100	140	180	212	265	216	252	14	12
F1	50-160	7,5	132M	65	50	100	189	396	685	340	160	180	132	89	70	100	178	218	212	265	216	252	14	12
F1	50-160	11	160M	65	50	100	226	466	792	340	160	180	160	108	70	100	210	311	212	265	254	298	14	15
F1	50-160	15	160M	65	50	100	226	466	792	340	160	180	160	108	70	100	210	311	212	265	254	298	14	15
F2	50-200	11	160M	65	50	100	226	466	792	360	160	200	160	108	70	100	210	311	212	265	254	298	14	15
F2	50-200	15	160M	65	50	100	226	466	792	360	160	200	160	108	70	100	210	311	212	265	254	298	14	15
F2	50-200	18,5	160M	65	50	100	226	466	792	360	160	200	160	108	70	100	210	311	212	265	254	298	14	15
F2	50-200	22	180M	65	50	100	226	519	845	380	160	200	180	121	70	100	241	343	212	265	279	344	14	15



2900 rpm (2 Pole Motor)

Kalasanati.com

FORM	Pump Type	MOTOR		ECO SNM INSTALLATION DIMENSIONS (mm)																							
				Overall Dimensions												Foot Dimensions											
				kW	IEC	DNe	DNb	A	W	Lm	L	H	h1	h2	h3	e	m1	m2	m3	m4	n1	n2	n3	n4	Sp	Sm	
F2	50-250	18,5	160L	65	50	100	226	466	792	405	180	225	160	108	95	125	210	311	250	320	254	298	14	15			
F2	50-250	22	180M	65	50	100	226	519	845	405	180	225	180	121	95	125	241	343	250	320	279	344	14	15			
F2	50-250	30	200L	65	50	100	226	555	881	425	180	225	200	133	95	125	305	365	250	320	318	388	14	19			
F1	65-125	4	112M	80	65	100	179	336	615	340	160	180	112	70	95	125	140	176	212	280	190	220	14	12			
F1	65-125	5,5	132S	80	65	100	189	360	649	340	160	180	132	89	95	125	140	180	212	280	216	252	14	12			
F1	65-125	7,5	132M	80	65	100	189	396	685	340	160	180	132	89	95	125	178	218	212	280	216	252	14	12			
F1	65-125	11	160M	80	65	100	226	466	792	340	160	180	160	108	95	125	210	311	212	280	254	298	14	15			
F1	65-160	7,5	132M	80	65	100	189	396	685	360	160	200	132	89	95	125	178	218	212	280	216	252	14	12			
F1	65-160	11	160L	80	65	100	226	466	792	360	160	200	160	108	95	125	210	311	212	280	254	298	14	15			
F1	65-160	15	160L	80	65	100	226	466	792	360	160	200	160	108	95	125	210	311	212	280	254	298	14	15			
F2	65-200	15	160L	80	65	100	226	466	792	405	180	225	160	108	95	125	210	311	250	320	254	298	14	15			
F2	65-200	18,5	160L	80	65	100	226	466	792	405	180	225	160	108	95	125	210	311	250	320	254	298	14	15			
F2	65-200	22	180M	80	65	100	226	519	845	405	180	225	180	121	95	125	241	343	250	320	279	344	14	15			
F2	65-200	30	200L	80	65	100	226	555	881	425	180	225	200	133	95	125	305	365	250	320	318	388	14	19			
F2	65-250	30	200L	80	65	100	246	555	901	450	200	250	200	133	120	160	305	365	280	360	318	388	19	19			
F2	65-250	37	200L	80	65	100	246	555	901	450	200	250	200	133	120	160	305	365	280	360	318	388	19	19			
F2	65-250	45	225M	80	65	100	248	625	973	475	200	250	225	149	120	160	311	383	280	360	356	442	19	19			
F2	65-250	55	250M	80	65	100	294	753	1147	500	200	250	250	168	120	160	349	409	280	360	406	506	19	24			
F1	80-160	11	160M	100	80	125	226	466	817	405	180	225	160	108	95	125	210	311	250	320	254	298	14	15			
F1	80-160	15	160M	100	80	125	226	466	817	405	180	225	160	108	95	125	210	311	250	320	254	298	14	15			
F1	80-160	18,5	160M	100	80	125	226	466	817	405	180	225	160	108	95	125	210	311	250	320	254	298	14	15			
F1	80-160	22	180	100	80	125	226	519	870	405	180	225	180	121	95	125	241	343	250	320	279	344	14	15			
F1	80-160	30	200L	100	80	125	226	555	906	425	180	225	200	133	95	125	305	365	250	320	318	388	14	19			
F1	80-200	22	180M	100	80	125	234	519	878	430	180	250	180	121	95	125	279	343	280	345	279	344	14	15			
F1	80-200	30	200L	100	80	125	236	555	916	450	180	250	200	133	95	125	305	365	280	345	318	388	14	19			
F1	80-200	37	200L	100	80	125	236	555	916	450	180	250	200	133	95	125	305	365	280	345	318	388	14	19			
F1	80-200	45	225M	100	80	125	238	625	988	475	180	250	225	149	95	125	311	383	280	345	356	442	14	19			
F2	80-250	37	200L	100	80	125	246	555	926	480	200	280	200	133	120	160	305	365	315	400	318	388	19	19			
F2	80-250	45	225M	100	80	125	248	625	998	505	200	280	225	149	120	160	311	383	315	400	356	442	19	19			
F2	80-250	55	250M	100	80	125	294	753	1172	530	200	280	250	168	120	160	349	409	315	400	406	506	19	24			
F2	80-250	75	280M	100	80	125	294	885	1304	560	200	280	280	188	120	160	419	500	315	400	457	554	19	24			
F2	80-250	90	280M	100	80	125	294	885	1304	560	200	280	280	188	120	160	419	500	315	400	457	554	19	24			
F1	100-160	22	180M	125	100	125	244	519	888	480	200	280	180	121	120	160	279	343	280	360	279	344	19	15			
F1	100-160	30	200L	125	100	125	246	555	926	480	200	280	200	133	120	160	305	365	280	360	318	388	19	19			
F1	100-160	37	200L	125	100	125	246	555	926	480	200	280	200	133	120	160	305	365	280	360	318	388	19	19			
F1	100-200	30	200L	125	100	125	246	555	926	480	200	280	200	133	120	160	305	365	280	360	318	388	19	19			
F1	100-200	37	200L	125	100	125	246	555	926	480	200	280	200	133	120	160	305	365	280	360	318	388	19	19			
F1	100-200	45	225M	125	100	125	248	625	998	505	200	280	225	149	120	160	311	383	280	360	356	442	19	19			
F1	100-200	55	250M	125	100	125	294	754	1173	530	200	280	250	168	120	160	349	409	280	360	406	506	19	24			
F2	100-250	45	225M	125	100	140	248	625	1013	505	225	280	225	149	120	160	311	383	315	400	356	442	19	19			
F2	100-250	55	250M	125	100	140	294	753	1187	530	225	280	250	168	120	160	349	409	315	400	406	506	19	24			
F2	100-250	75	280M	125	100	140	294	885	1319	560	225	280	280	188	120	160	419	500	315	400	457	554	19	24			
F2	100-250	90	280M	125	100	140	294	885	1319	560	225	280	280	188	120	160	419	500	315	400	457	554	19	24			
F1	125-200	55	250M	150	125	140	294	753	1187	565	250	315	250	168	120	160	349	409	315	400	406	506	19	24			
F1	125-200	75	280M	150	125	140	294	885	1319	595	250	315	280	188	120	160	419	500	315	400	457	554	19	24			
F1	125-200	90	280M	150	125	140	294	885	1319	595	250	315	280	188	120	160	419	500	315	400	457	554	19	24			

1450 rpm (4 Pole Motor)

FORM	Pump Type	MOTOR		ECO SNM INSTALLATION DIMENSIONS (mm)																							
				Overall Dimensions												Foot Dimensions											
				kW	IEC	DNe	DNb	A	W	Lm	L	H	h1	h2	h3	e	m1	m2	m3	m4	n1	n2	n3	n4	Sp	Sm	
F1	32-125	0,37	160L	50	32	80	136	222	439	252	112	140	71	45	70	100	90	106	140	190	112	128	14	7			
F1	32-125	0,55	180M	50	32	80	156	244	480	252	112	140	80	50	70	100	100	120	140	190	125	165	14	10			
F1	32-160	0,37	200L	50	32	80	136	222	439	292	132	160	71	45	70	100	90	106	190	240	112	128	14	7			
F1	32-160	0,55	112M	50	32	80	156	244	480	292	132	160	80	50	70	100	100	120	190	240	125	165	14	10			
F1	32-160	0,75	132S	50	32	80	156	244	480	292	132	160	80	50	70	100	100	120	190	240	125	165	14	10			
F2	32-200	0,75	132M	50	32	80	156	244	480	340	160	180	80	50	70	100	100	120	190	240	125	165	14	10			
F2	32-200	1,1	160M	50	32	80	156	267	503	340	160	180	90	56	70	100	125	158	190	240	140	190	14	10			
F2	32-200	1,5	132M	50	32	80	156	267	503	340	160	180	90	56	70	100	125	158	190	240	140	190	14	10			
F2	32-250	1,1	160L	50	32	100	156	267	523	405	180	225	90	56	95	125	125	158	250	320	140	190	14	10			
F2	32-250	1,5	160L	50	32	100	156	267	523	405	180	225	90	56	95	125	125	158	250	320	140	190	14	10			
F2	32-250	2,2	160L	50	32	100	179	292	571	405	180	225	100	63	95	125	140	178	250	320	160	192	14	12			
F																											



Kalasanati.com

1450 rpm (4 Pole Motor)

FORM	Pump Type	MOTOR		ECO SNM INSTALLATION DIMENSIONS (mm)																				
				Overall Dimensions												Foot Dimensions								
				kW	IEC	DNe	DNb	A	W	Lm	L	H	h1	h2	h3	e	m1	m2	m3	m4	n1	n2	n3	n4
F2	40-200	1,1	90L	65	40	100	156	266	523	340	160	180	90	56	70	100	125	158	212	265	140	190	14	10
F2	40-200	1,5	90L	65	40	100	156	266	523	340	160	180	90	56	70	100	125	158	212	265	140	190	14	10
F2	40-200	2,2	90L	65	40	100	179	292	571	340	160	180	90	63	70	100	140	178	212	265	160	192	14	12
F2	40-250	2,2	100L	65	40	100	179	292	571	405	180	225	100	63	70	125	140	178	250	320	160	192	14	12
F2	40-250	3	100L	65	40	100	179	292	571	405	180	225	100	63	70	125	140	178	250	320	160	192	14	12
F2	40-250	4	112M	65	40	100	179	335	614	405	180	225	112	63	70	125	140	176	250	320	190	220	14	12
F2	40-315	3	100L	65	40	100	177	292	569	450	200	250	100	63	95	125	140	178	280	345	160	192	14	12
F2	40-315	4	112M	65	40	100	177	335	612	450	200	250	112	70	95	125	140	176	280	345	190	220	14	12
F2	40-315	5,5	132M	65	40	100	187	396	683	450	200	250	132	89	95	125	178	218	280	345	216	252	14	12
F2	40-315	7,5	132M	65	40	100	187	396	683	450	200	250	132	89	95	125	178	218	280	345	216	252	14	12
F1	50-125	0,55	80M	65	50	100	156	244	500	292	132	160	80	50	70	100	100	120	190	240	125	165	14	10
F1	50-125	0,75	80M	65	50	100	156	244	500	292	132	160	80	50	70	100	100	120	190	240	125	165	14	10
F1	50-125	1,1	90L	65	50	100	156	267	523	292	132	160	90	56	70	100	125	158	190	240	140	190	14	10
F1	50-160	0,75	80M	65	50	100	156	243	500	340	160	180	80	50	70	100	100	120	212	265	125	165	14	10
F1	50-160	1,1	90L	65	50	100	156	267	523	340	160	180	90	56	70	100	125	158	212	265	140	190	14	10
F1	50-160	1,5	90L	65	50	100	156	267	523	340	160	180	90	56	70	100	125	158	212	265	140	190	14	10
F1	50-160	2,2	100L	65	50	100	179	292	571	340	160	180	100	63	70	100	140	178	212	265	160	192	14	12
F2	50-200	1,1	90L	65	50	100	156	267	523	360	160	200	90	56	70	100	125	158	212	265	140	190	14	10
F2	50-200	1,5	90L	65	50	100	156	267	523	360	160	200	90	56	70	100	125	158	212	265	140	190	14	10
F2	50-200	2,2	100L	65	50	100	179	292	571	360	160	200	100	63	70	100	140	178	212	265	160	192	14	12
F2	50-200	3	100L	65	50	100	179	292	571	360	160	200	100	63	70	100	140	178	212	265	160	192	14	12
F2	50-250	2,2	100L	65	50	100	179	292	571	405	180	225	100	63	95	125	140	178	250	320	160	192	14	12
F2	50-250	3	100L	65	50	100	179	292	571	405	180	225	100	63	95	125	140	178	250	320	160	192	14	12
F2	50-250	4	112M	65	50	100	179	336	615	405	180	225	112	70	95	125	140	176	250	320	190	220	14	12
F2	50-250	5,5	132M	65	50	100	189	396	685	405	180	225	132	89	95	125	178	218	250	320	216	252	14	12
F2	50-315	5,5	132M	65	50	125	214	396	735	505	225	280	132	89	95	125	178	218	280	345	216	252	14	12
F2	50-315	7,5	132M	65	50	125	214	396	735	505	225	280	132	89	95	125	178	218	280	345	216	252	14	12
F2	50-315	11	160M	65	50	125	244	466	835	505	225	280	160	108	95	125	254	311	280	345	254	298	14	15
F1	65-125	0,55	80M	80	65	100	156	243	500	340	160	180	80	50	95	125	100	120	212	280	125	165	14	10
F1	65-125	0,75	80M	80	65	100	156	243	500	340	160	180	80	50	95	125	100	120	212	280	125	165	14	10
F1	65-125	1,1	90L	80	65	100	156	267	523	340	160	180	90	56	95	125	125	158	212	280	140	190	14	10
F1	65-160	1,1	90L	80	65	100	156	267	523	360	160	200	90	56	95	125	125	158	212	280	140	190	14	10
F1	65-160	1,5	90L	80	65	100	156	267	523	360	160	200	90	56	95	125	125	158	212	280	140	190	14	10
F1	65-160	2,2	100L	80	65	100	179	292	571	360	160	200	100	63	95	125	140	178	212	280	160	192	14	12
F2	65-200	1,5	90L	80	65	100	156	266	523	405	180	225	90	56	95	125	125	158	250	320	140	190	14	10
F2	65-200	2,2	100L	80	65	100	179	292	571	405	180	225	100	63	95	125	140	178	250	320	160	192	14	12
F2	65-200	3	100L	80	65	100	179	292	571	405	180	225	100	63	95	125	140	178	250	320	160	192	14	12
F2	65-200	4	112M	80	65	100	179	336	615	405	180	225	112	70	95	125	140	176	250	320	190	220	14	12
F2	65-250	3	100L	80	65	100	189	292	581	450	200	250	100	63	120	160	140	178	280	360	160	192	19	12
F2	65-250	4	112M	80	65	100	189	336	625	450	200	250	112	70	120	160	140	176	280	360	190	220	19	12
F2	65-250	5,5	132M	80	65	100	214	396	710	450	200	250	132	89	120	160	178	218	280	360	216	252	19	12
F2	65-250	7,5	132M	80	65	100	214	396	710	450	200	250	132	89	120	160	178	218	280	360	216	252	19	12
F2	65-315	5,5	132M	80	65	125	214	396	735	505	225	280	132	89	120	160	178	218	315	400	216	252	19	12
F2	65-315	7,5	132M	80	65	125	214	396	735	505	225	280	132	89	120	160	178	218	315	400	216	252	19	12
F2	65-315	11	160M	80	65	125	244	466	835	505	225	280	160	108	120	160	254	311	315	400	254	298	19	15
F2	65-315	15	160M	80	65	125	244	466	835	505	225	280	160	108	120	160	254	311	315	400	254	298	19	15
F2	65-400	15	160M	100	65	125	244	466	835	615	260	355	160	108	120	160	254	311	355	435	254	298	19	15
F2	65-400	18,5	180M	100	65	125	244	519	888	615	260	355	180	121	120	160	279	343	355	435	279	344	19	15
F2	65-400	22	180M	100	65	125	244	519	888	615	260	355	180	121	120	160	279	343	355	435	279	344	19	15
F2	65-400	30	200L	100	65	125	246	555	926	615	260	355	200	133	120	160	305	365	355	435	318	388	19	19
F1	80-160	1,5	90L	100	80	125	156	266	548	405	180	225	90	56	95	125	125	158	250	320	140	190	14	10
F1	80-160	2,2	100L	100	80	125	179	292	596	405	180	225	100	63	95	125	140	178	250	320	160	192	14	12
F1	80-160	3	100L	100	80	125	179	292	596	405	180	225	100	63	95	125	140	178	250	320	160	192	14	12
F1	80-200	3	100L	100	80	125	179	292	596	430	180	250	100	63	95	125	140	178	280	345	160	192	14	12
F1	80-200	4	112M	100	80	125	179	336	640	430	180	250	112	70	95	125	140	176	280	345	190	220	14	12
F1	80-200	5,5	132M	100	80	125	204	396	725	430	180	250	132	89	95	125	178	218	280	345	216	252	14	12
F2	80-250	4	112M	100	80	125	189	336	650	480	200	280	112	70	120	160	140	176	315	400	190	220	19	12
F2	80-250	5,5	132M	100	80	125	214	396	735	480	200	280	132	89	120	160	178	218	315	400	216	252	19	12
F2	80-250	7,5	132M	100	80	125	214	396	735	480	200	280	132	89	120	160	178	218	315	400	216	252	19	12
F2	80-250	11	160M	100	80	125	244	466																



Kalasanati.com

ECO SNM

1450 rpm (4 Pole Motor)

FORM	Pump Type	MOTOR		ECO SNM INSTALLATION DIMENSIONS (mm)																				
				Overall Dimensions										Foot Dimensions										
				kW	IEC	DNe	DNb	A	W	Lm	L	H	h1	h2	h3	e	m1	m2	m3	m4	n1	n2	n3	n4
F2	100-250	5,5	132M	125	100	140	214	396	750	505	225	280	132	89	120	160	178	218	315	400	216	252	19	12
F2	100-250	7,5	132M	125	100	140	214	396	750	505	225	280	132	89	120	160	178	218	315	400	216	252	19	12
F2	100-250	11	160M	125	100	140	244	466	850	505	225	280	160	108	120	160	254	311	315	400	254	298	19	15
F2	100-250	15	160M	125	100	140	244	466	850	505	225	280	160	108	120	160	254	311	315	400	254	298	19	15
F2	100-315	15	160M	125	100	140	244	466	850	565	250	315	160	108	120	160	254	311	315	400	254	298	19	15
F2	100-315	18,5	180M	125	100	140	244	519	903	565	250	315	180	121	120	160	279	343	315	400	279	344	19	15
F2	100-315	22	180M	125	100	140	244	519	903	565	250	315	180	121	120	160	279	343	315	400	279	344	19	15
F2	100-315	30	200L	125	100	140	246	555	941	565	250	315	200	133	120	160	305	365	315	400	318	388	19	19
F2	100-400	22	180M	125	100	140	245	519	904	635	280	355	180	121	150	200	279	343	400	500	279	344	19	15
F2	100-400	30	200L	125	100	140	245	555	940	635	280	355	200	133	150	200	305	365	400	500	318	388	19	19
F2	100-400	37	225M	125	100	140	305	625	1070	635	280	355	200	133	150	200	305	365	400	500	318	388	19	19
F2	100-400	45	225M	125	100	140	305	625	1070	635	280	355	225	149	150	200	311	383	400	500	356	442	19	19
F2	100-400	55	250M	125	100	140	305	746	1195	635	280	355	250	168	150	200	349	421	400	500	406	506	19	24
F2	100-400	75	280M	125	100	140	305	885	1330	635	280	355	280	190	150	200	419	498	400	500	457	554	19	24
F2	100-400	90	280M	125	100	140	305	885	1330	635	280	355	280	190	150	200	419	498	400	500	457	554	19	24
F1	125-200	7,5	132M	150	125	140	214	396	750	565	250	315	132	89	120	160	178	218	315	400	216	252	19	12
F1	125-200	11	160M	150	125	140	244	466	850	565	250	315	160	108	120	160	254	311	315	400	254	298	19	15
F2	125-250	15	160M	150	125	140	244	466	850	605	250	355	160	108	120	160	254	311	315	400	254	298	19	15
F2	125-250	18,5	180M	150	125	140	244	519	903	605	250	355	180	121	120	160	279	343	315	400	279	344	19	15
F2	125-250	22	180M	150	125	140	244	519	903	605	250	355	180	121	120	160	279	343	315	400	279	344	19	15
F1	125-315	11	160M	150	125	140	256	466	862	635	280	355	160	108	150	220	254	311	400	500	254	298	23	15
F1	125-315	15	160M	150	125	140	256	466	862	635	280	355	160	108	150	220	254	311	400	500	254	298	23	15
F1	125-315	18,5	180M	150	125	140	256	519	915	635	280	355	180	121	150	220	279	343	400	500	279	344	23	15
F1	125-315	22	180M	150	125	140	256	519	915	635	280	355	180	121	150	220	279	343	400	500	279	344	23	15
F1	125-315	30	200L	150	125	140	256	555	951	635	280	355	200	133	150	220	305	365	400	500	318	388	23	19
F1	125-315	37	225M	150	125	140	316	625	1081	635	280	355	225	149	150	220	305	365	400	500	356	442	23	19
F1	125-315	45	225M	150	125	140	316	625	1081	635	280	355	225	149	150	220	305	365	400	500	356	442	23	19
F2	125-400	37	225M	150	125	140	316	625	1081	715	315	400	225	149	150	200	311	383	400	500	356	442	23	19
F2	125-400	45	225M	150	125	140	316	625	1081	715	315	400	225	149	150	200	311	383	400	500	356	442	23	19
F2	125-400	55	250M	150	125	140	316	753	1209	715	315	400	250	168	150	200	349	409	400	500	406	506	23	24
F2	125-400	75	280M	150	125	140	316	869	1325	715	315	400	280	180	150	200	419	501	400	500	457	554	23	24
F2	125-400	90	280M	150	125	140	316	869	1325	715	315	400	280	180	150	200	419	501	400	500	457	554	23	24
F1	150-200	11	160M	200	150	160	244	466	870	635	280	355	160	108	150	200	254	311	400	500	254	298	23	15
F1	150-200	15	160M	200	150	160	244	466	870	635	280	355	160	108	150	200	254	311	400	500	254	298	23	15
F2	150-250	15	160M	200	150	160	244	466	870	655	280	375	160	108	150	200	254	311	400	500	254	298	23	15
F2	150-250	18,5	180M	200	150	160	244	519	923	655	280	375	180	121	150	200	279	343	400	500	279	344	23	15
F2	150-250	22	180M	200	150	160	244	519	923	655	280	375	180	121	150	200	279	343	400	500	279	344	23	15
F2	150-250	30	200L	200	150	160	246	555	961	655	280	375	200	133	150	200	305	365	400	500	318	388	23	19
F1	150-315	18,5	180M	200	150	160	316	753	1229	680	280	400	180	168	150	200	349	409	450	550	279	344	23	24
F1	150-315	22	180M	200	150	160	316	753	1229	680	280	400	180	168	150	200	349	409	450	550	279	344	23	24
F1	150-315	30	200L	200	150	160	256	555	971	680	280	400	200	133	150	200	305	365	450	550	318	388	23	19
F1	150-315	37	225M	200	150	160	316	625	1101	680	280	400	225	149	150	200	311	383	450	550	318	388	23	19
F1	150-315	45	225M	200	150	160	316	625	1101	680	280	400	225	149	150	200	311	383	450	550	356	442	23	19
F1	150-315	55	250M	200	150	160	316	753	1229	680	280	400	250	168	150	200	349	409	450	550	406	506	23	24
F2	150-400	45	225M	200	150	160	316	625	1101	765	315	450	225	149	150	200	311	383	450	550	356	442	23	19
F2	150-400	55	250M	200	150	160	316	746	1222	765	315	450	250	168	150	200	349	421	450	550	406	506	23	24
F2	150-400	75	280M	200	150	160	316	885	1361	765	315	450	280	190	150	200	419	498	450	550	457	554	23	24
F2	150-400	90	280M	200	150	160	316	885	1361	765	315	450	280	190	150	200	419	498	450	550	457	554	23	24



Kalasanati.com

ECO SNM

Installation Arrangements

ECO SNM / ECO SNM-V pumps can be installed in different arrangements

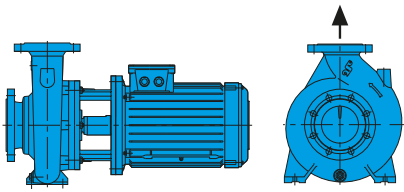

Horizontal installation on ground
Horizontal position on a base plate

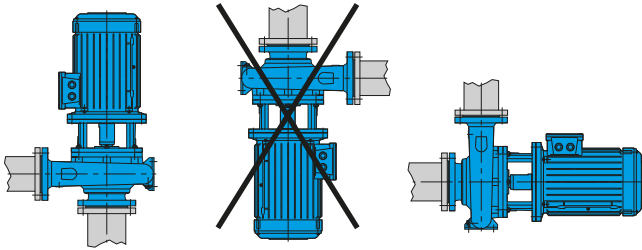

Installation on perpendicular pipes
•Between two perpendicular pipes in horizontal or vertical position. The axis of motor below the horizontal line is not admissible.

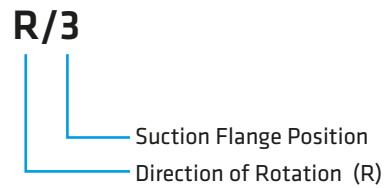
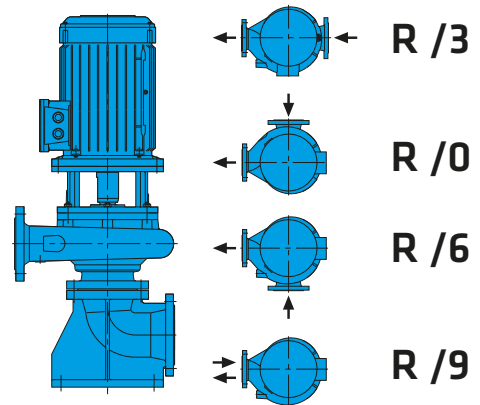

Direction of rotation viewed from driver end: R : Right

Vertical installation on ground

- Vertical position by means of a special suction elbow with foot.
- Standard manufacturing is as in the drawings above (R/3). Suction elbow position can be adjusted for different positions.



Kalasanati.com

ECO SNM

Assembly Drawings

Form: F1 (Slide - fit shaft application)

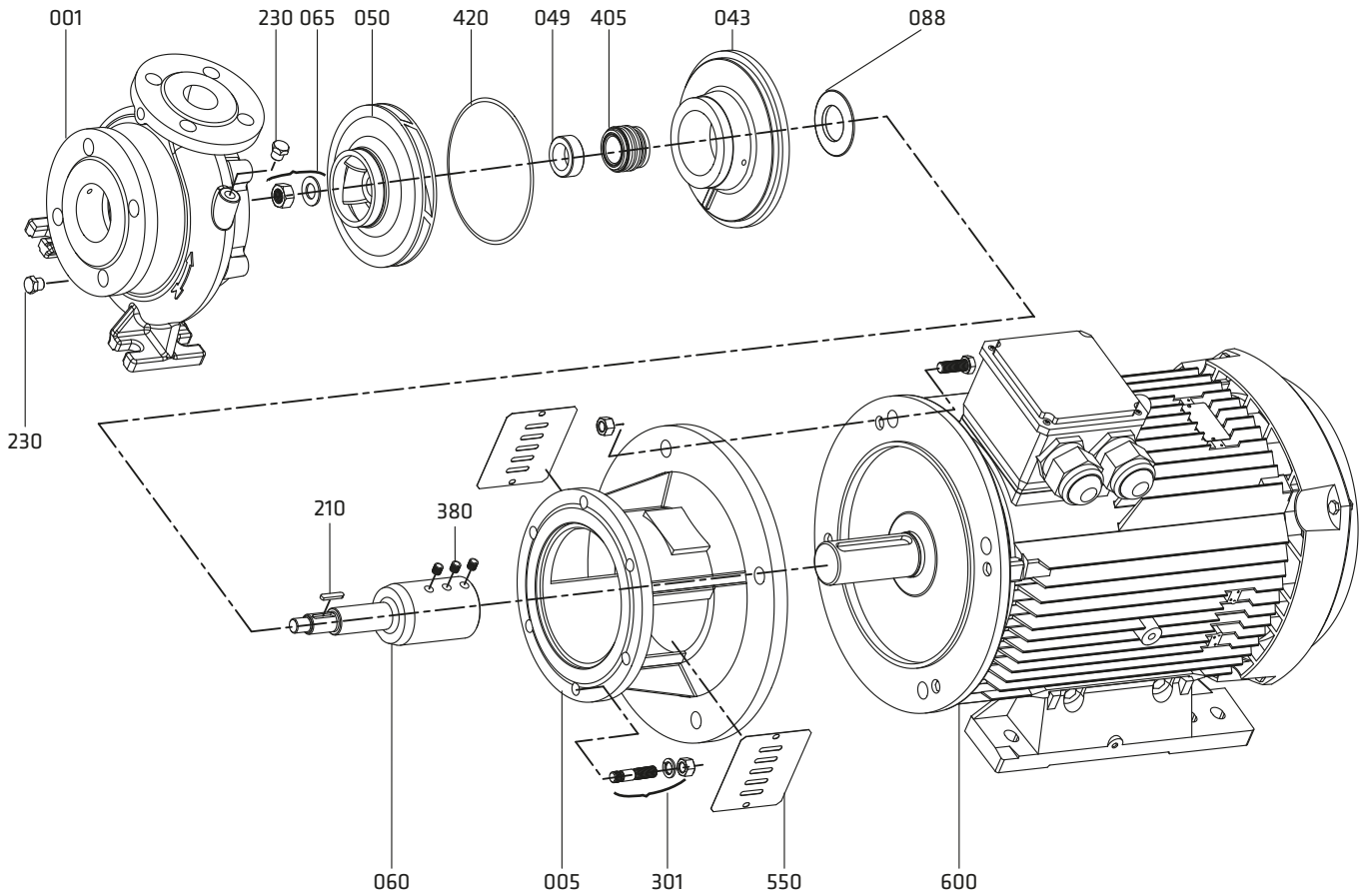

Form: F2 (Slide - fit shaft application)

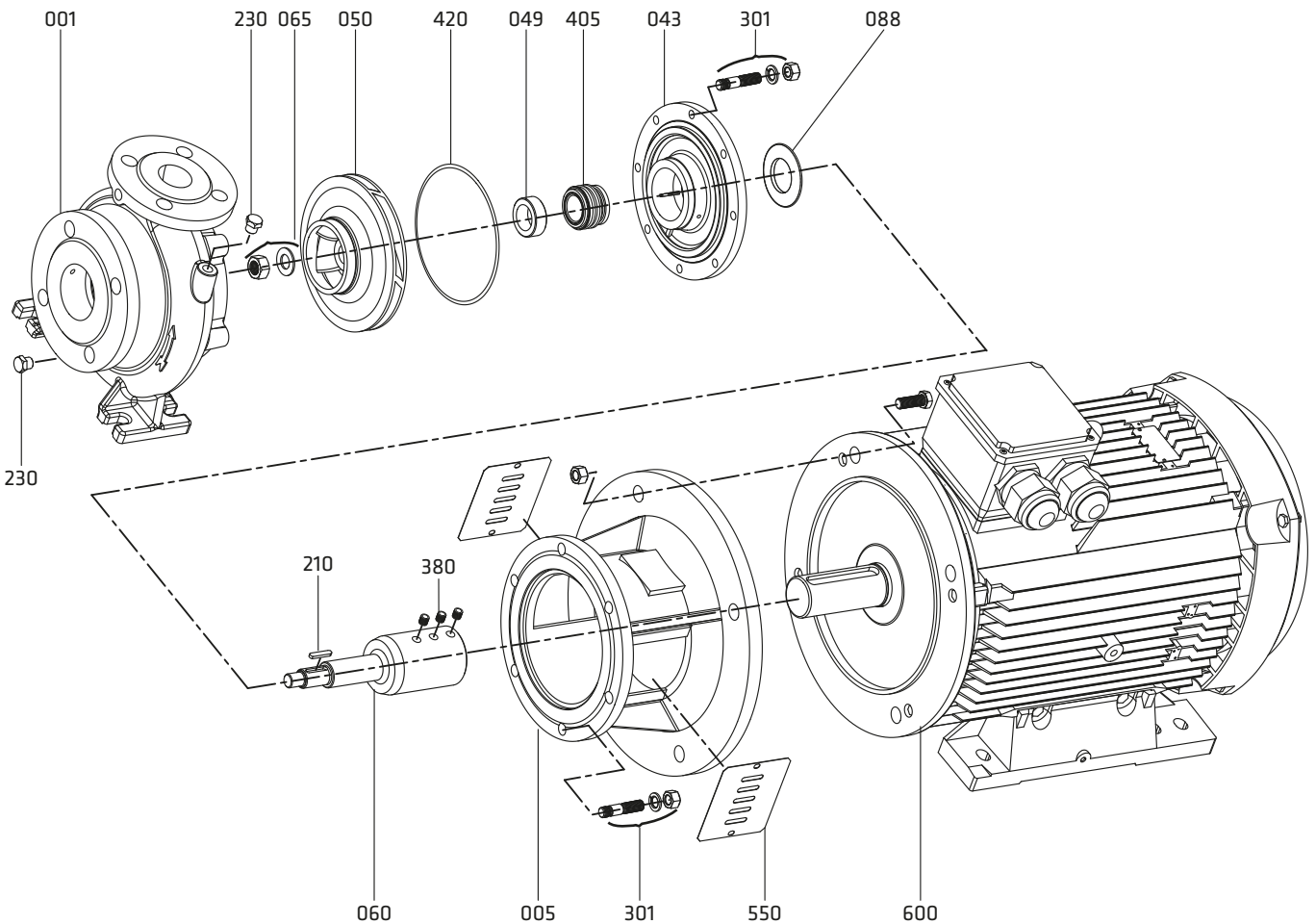



Kalasanati.com

ECO SNM

Rigid Coupling Application

For motor shaft diameters of Ø60 mm or bigger.

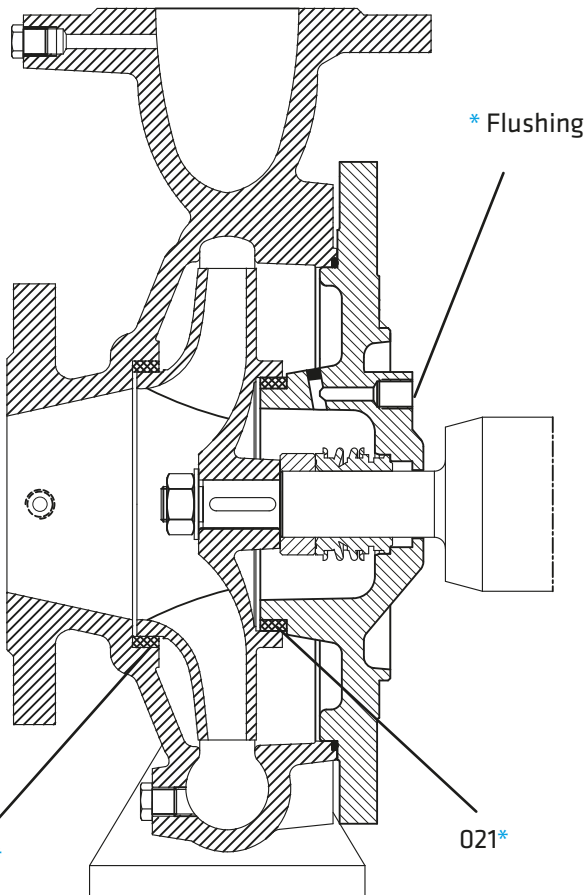
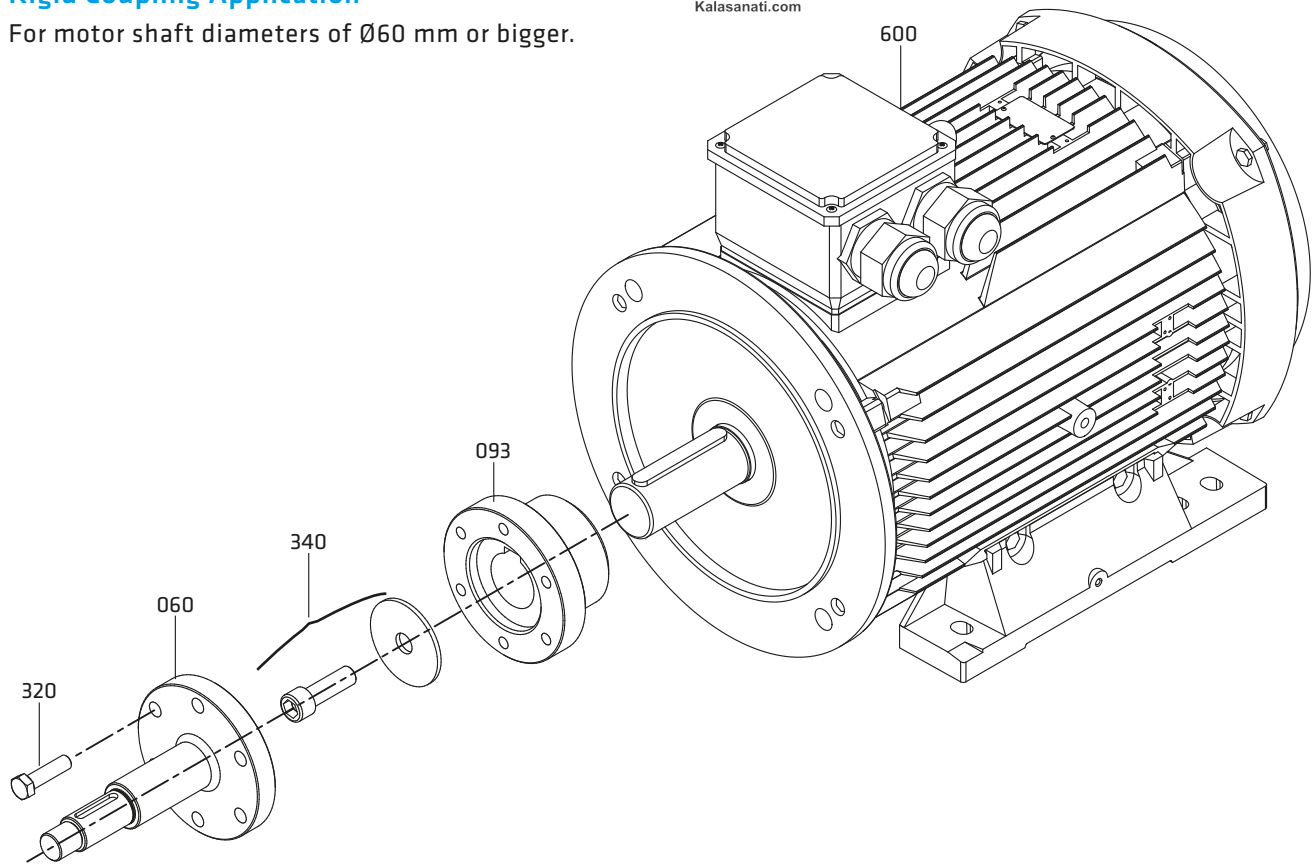

Part List

001	Volute Casing
005	Motor Pedestal
020*	Wear Ring (casing)
021*	Wear Ring (seal cover)
043	Mechanical Seal Cover
049	Mechanical Seal Spacer Sleeve
050	Impeller
060	Shaft
065	Impeller Nut and Washer
088	Thrower
093	Rigid Coupling
210	Impeller Key
230	Screw
301	Stud, Washer and Nut
320	Screw
340	Allen Screw and Washer
380	Set Screw
405	Mechanical Seal
420	O-ring
550	Guard
600	Electric Motor

(*) Optional



Kalasanati.com

Technical Data

Part List	10	30	35	20	60	6L	70	7L	8M	7D	7S	8N	80	4C	4A	40	80	8T	60	7L	7E	7D	
	0.6025	0.7040	0.7043	1.0619	1.4308	1.4309	1.4408	1.4409	1.4500	1.4517	1.4469	1.4317	1.4008	2.1050.01	2.0975.01	2.1096.01	1.4021	1.4021+QT	1.4301	1.4404	1.4460	1.4462	
Volute Casing	●	○	○	○	○	○	○	○	○	○	○	○	○	○									
Mechanical Seal Cover	●	○	○	○	○	○	○	○	○	○	○	○	○	○									
Impeller	●	○	○	○	○	○	○	○	○	○	○	○	○	○	○	○						○	
Shaft																	●	○	○	○			○
Bearing Housing	●	○	○	○	○	○	○	○															
Wear Ring	○	○	○	○	○	○	○	○	○	○	○	○	○	○	○	○							
Mech. Seal Spacer Sleeve																	●	○	○	○			○
Mechanical Seal (*)	EN 12756																						

(*) Optional :Depending on customer requirement or request different types and brands of mechanical seals are applicable.

● Standard manufacturing

NOTE: Depends on the request, different than above casting and shaft material can be supplied.

○ Optional

Material Equivalents

Description	DIN / EN		AISI / SAE / ASTM
Cast Iron	0.6025	EN-GJL-250 (GG25)	A48 Class 40B
Nodular Cast Iron	0.7040	EN-GJS-400-15 (GGG40)	A536 60-40-18
Nodular Cast Iron	0.7043	EN-GJS-400-18-LT (GGG40.3)	A536 60-40-18
Cast Steel	1.0619	GP240GHGS-C25	A216 WCB
Chrome Nickel Cast Steel	1.4308	GX5CrNi19-10	A351 CF8
Chrome Nickel Cast Steel (low carbon)	1.4309	GX2CrNi19-11	A351 CF3
Chrome Nickel Molybdenum Cast Steel	1.4408	GX5CrNiMo19-11-2	A351 CF8M
Chrome Nickel Molybdenum Cast Steel (low carbon)	1.4409	GX2CrNiMo19-11-2	A351 CF3M
Austenitic Cast Steel	1.4500	GX7NiCrMoCuNb25-20	A351 CN7M
Austenitic - Ferritic Cast Steel (duplex)	1.4517	GX2CrNiMoCuN25-6-3-3	A890 CD4MCuN
Austenitic - Ferritic Cast Steel (super duplex)	1.4469	GX2CrNiMoN26-7-4	A890 CE3MN
Martenzitic Stainless Cast Steel	1.4317	GX4CrNi13-4	A352 CA6NM
Martenzitic Stainless Cast Steel	1.4008	GX7CrNiMo12-1	A217 CA15
Cast Bronze (tin alloy)	2.1050.01	G-CuSn10	B427 C90700
Cast Bronze (nickel alloy)	2.0975.01	G-CuAl10Ni	B148 C95500
Cast Bronze (Leaded)	2.1096.01	G-CuSn5ZnPb	B584 C83600
Chrome Steel	1.4021	X20Cr13	A276 Type 420
Chrome Steel(heat treated)	1.4021	X20Cr13	A276 Type 420+QT
Chrome Nickel Steel	1.4301	X5CrNi18-10	A276 Type 304
Chrome Nickel Steel (low carbon)	1.4404	X2CrNiMo17-12-2	A276 Type 316L
Duplex (austenitic-ferritic) Steel	1.4460	X3CrNiMoN27-5-2	AISI 329
Duplex (austenitic-ferritic) Steel	1.4462	X2CrNiMoN22-5-3	UNS S32205

Flange Dimensions

EN 1092 - 2

DNe/DNb	Suction & Discharge (PN 16)			
	Df	k	s	n
32	140	100	19	4
40	150	110	19	4
50	165	125	19	4
65	185	145	19	4
80	200	160	19	8
100	220	180	19	8
125	250	210	19	8
150	285	240	23	8
200	340	295	23	12

" n " number of holes

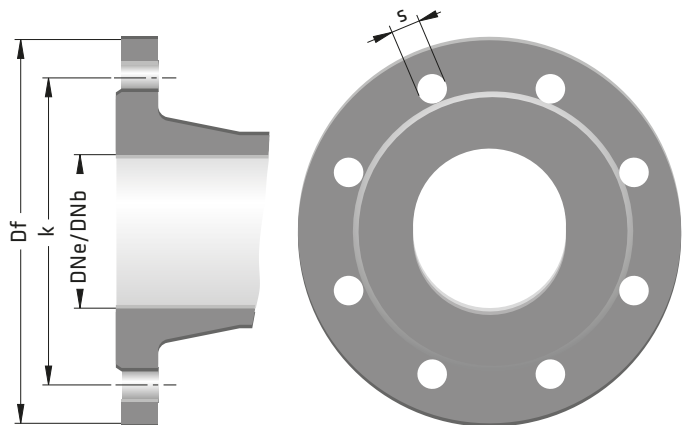



Pump • Fire Fighting Units • Booster Set

ECO SNL IN-LINE PUMPS



Kalasanati.com



Handled Liquids

Clean or slightly contaminated low viscosity liquids without solid & fibrous particles.

Technical Data

Discharge Flange _____ DN 40.....DN 150 mm

Capacity _____ up to 350 m³/h(*)

Head _____ up to 100 m(*)

Speed _____ up to 3000 rpm

Design Temperature _____ -10 °C' to +140 °C(**)

Casing Pressure (Pmax) _____ 10 bar (16 bar)(**)

(Pmax: Suction Pressure + Shut off Head)

(*) Contact company for higher capacity and head values.

(**) The Material of pump differs according to the type of pumped liquid, operating temperature and pressure. Contact for detailed information.

Design Features

• In-line, rigidly-coupled, volute casing, single stage centrifugal pump with closed impeller.

• Complies EU547/2012 regulations.

• Suction and discharge flanges conform to EN 1092-2 / PN 16. The flanges are according to EN 1092-1 / PN 16 for steel or stainless steel casing. In case of request, ANSI/ASME flanges can be supplied.

Pump Designation

Pump Type _____

Suction and Discharge Nozzle (DN-mm) _____

Nominal Impeller Diameter (mm) _____

Special Application _____

ECO SNL 100 - 250 - XXX

• Pumps are rigidly coupled with electric motors of IEC frame sizes with high efficiency class.

• All impellers are balanced dynamically or statically according to ISO 1940 grade 6.3.

• Axial thrust is balanced by impeller balancing holes system.

• Direction of rotation is clockwise viewed from drive end.

• In case of request, wear ring and/or shaft sleeve can be supplied.

• The pump and motor have separate shafts connected by a rigid coupling or through slide fit shaft. Axial and radial forces are absorbed by electric motor bearings.

• For ECO SNL drawings, please look at below address www.standartpompa.com.

Shaft Sealing

• Depending on customer request or liquid type, mechanical seals are available.

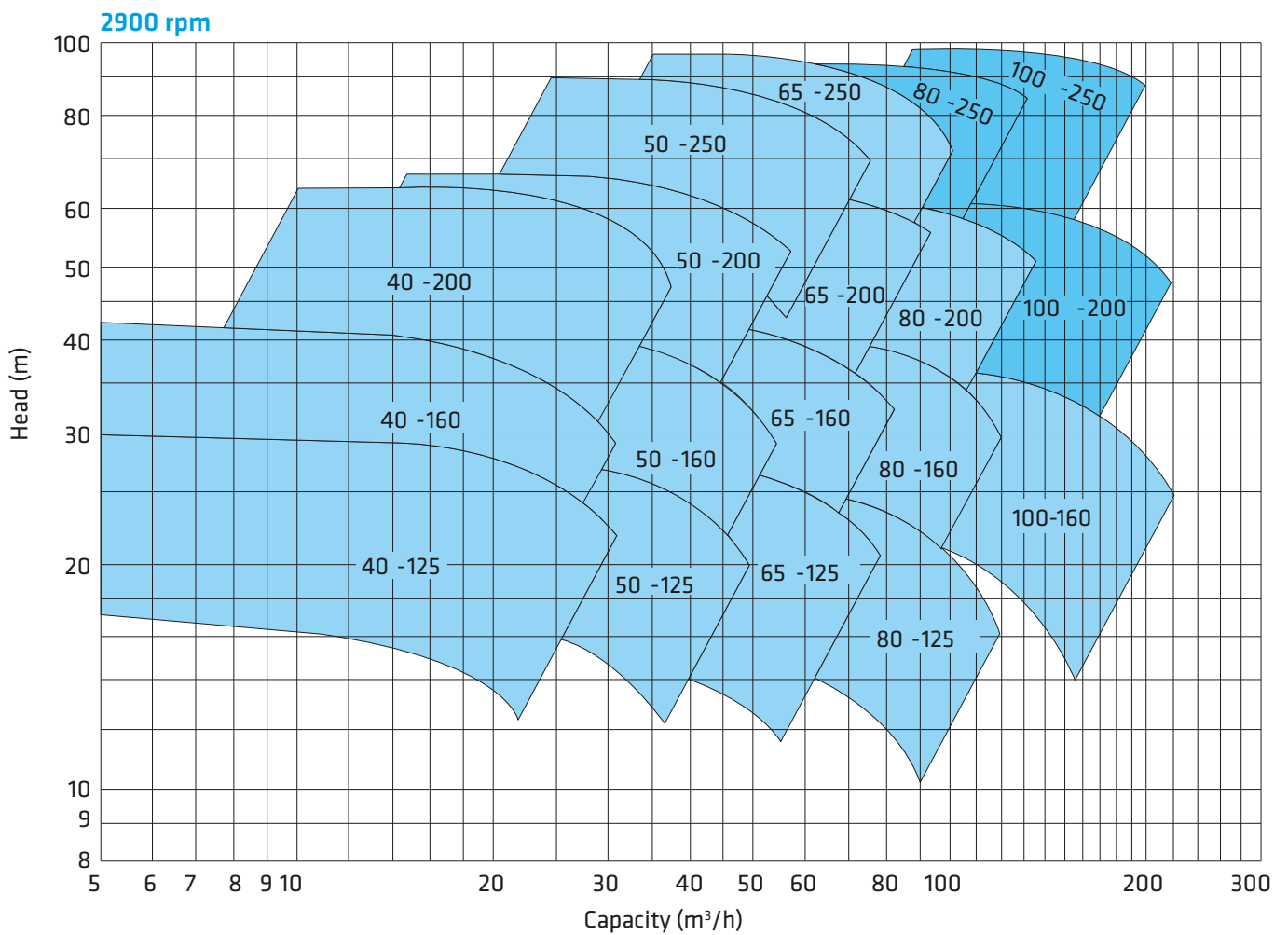
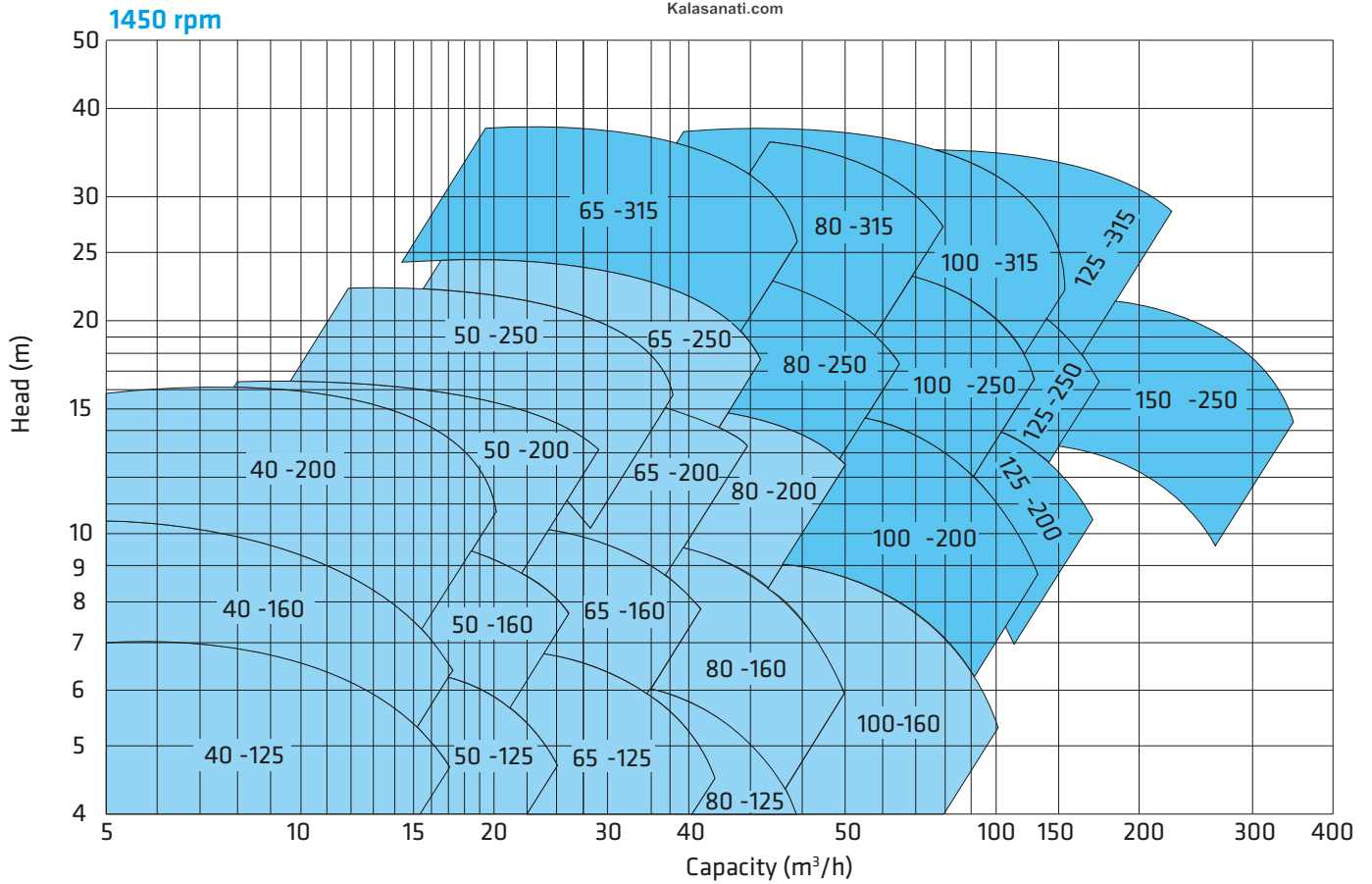

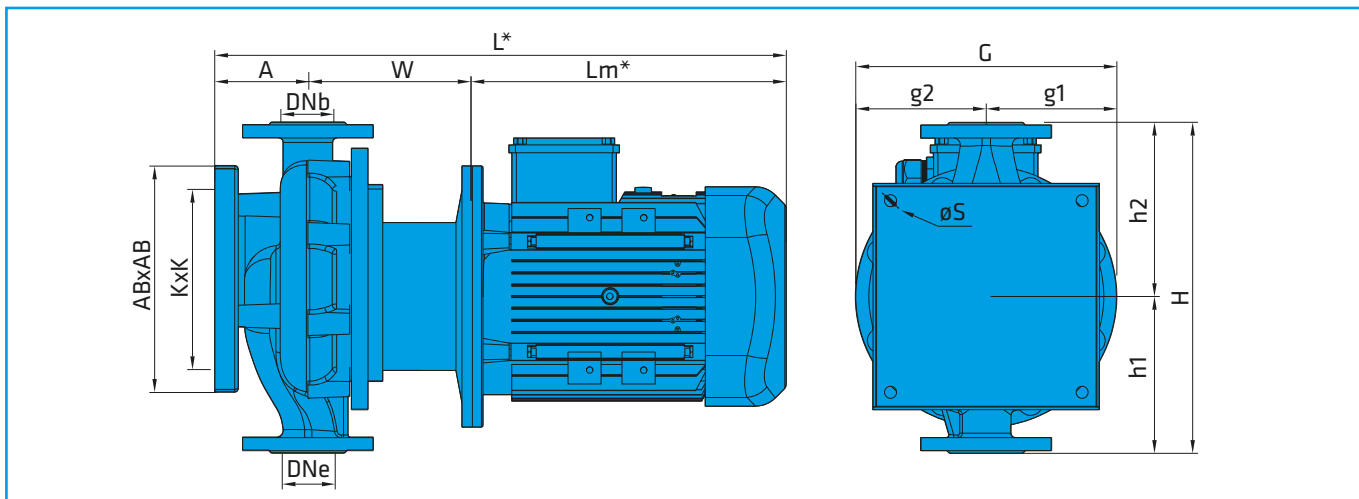

2900 rpm (2 Pole Motor)

FORM	Pump Type	MOTOR		DNe DNB mm	ECO SNL INSTALLATION DIMENSIONS (mm)														Base Plate (**)
		kW	IEC		A	W	Lm*	L*	H	h1	h2	G	g1	g2	ABxAB	KxK	øS		
F1	40-125	1,5	90L	40	109	156	267	532	300	140	160	210	110	100	170	130	14	T0	
F1	40-125	2,2	90L	40	109	156	267	532	300	140	160	210	110	100	170	130	14	T0	
F1	40-125	3	100L	40	109	179	292	580	300	140	160	210	110	100	170	130	14	T1	
F1	40-125	4	112M	40	109	179	336	624	300	140	160	210	110	100	170	130	14	T1	
F1	40-160	2,2	90L	40	103	156	267	526	340	160	180	245	130	115	170	130	14	T0	
F1	40-160	3	100L	40	103	179	292	574	340	160	180	245	130	115	200	160	14	T1	
F1	40-160	4	112M	40	103	179	336	618	340	160	180	245	130	115	200	160	14	T1	
F1	40-160	5,5	132S	40	103	189	361	652	340	160	180	245	130	115	200	160	14	T1	
F2	40-200	5,5	132S	40	107	189	360	657	380	180	200	275	140	135	260	220	14	T2	
F2	40-200	7,5	132M	40	107	189	396	692	380	180	200	275	140	135	260	220	14	T2	
F2	40-200	11	160M	40	107	226	466	799	380	180	200	275	140	135	260	220	14	T2	
F1	50-125	2,2	90L	50	133	156	267	556	360	160	200	220	120	100	200	160	14	T1	
F1	50-125	3	100L	50	133	179	292	604	360	160	200	220	120	100	200	160	14	T1	
F1	50-125	4	112M	50	133	179	335	647	360	160	200	220	120	100	200	160	14	T1	
F1	50-125	5,5	132S	50	133	189	361	683	360	160	200	220	120	100	200	160	14	T1	
F1	50-160	4	112M	50	138	179	336	653	340	160	180	255	135	120	200	160	14	T1	
F1	50-160	5,5	132S	50	138	189	361	687	340	160	180	255	135	120	200	160	14	T1	
F1	50-160	7,5	132M	50	138	189	396	723	340	160	180	255	135	120	200	160	14	T1	
F2	50-200	7,5	132M	50	122	189	396	707	425	200	225	280	145	135	260	220	14	T2	
F2	50-200	11	160M	50	122	226	466	814	425	200	225	280	145	135	260	220	14	T2	
F2	50-200	15	160M	50	122	226	466	814	425	200	225	280	145	135	260	220	14	T2	
F2	50-200	18,5	160M	50	122	226	466	814	425	200	225	280	145	135	260	220	14	T2	
F2	50-250	15	160L	50	117	226	466	809	475	225	250	340	175	165	260	220	14	T2	
F2	50-250	18,5	160L	50	117	226	466	809	475	225	250	340	175	165	260	220	14	T2	
F2	50-250	22	180M	50	117	226	519	862	475	225	250	340	175	165	260	220	14	T2	
F2	50-250	30	200L	50	124	226	555	905	475	225	250	340	175	165	320	270	18	T3	
F1	65-125	3	100L	65	163	179	292	634	340	160	180	250	140	110	200	160	14	T1	
F1	65-125	4	112M	65	163	179	336	678	340	160	180	250	140	110	200	160	14	T1	
F1	65-125	5,5	132S	65	163	189	360	712	340	160	180	250	140	110	200	160	14	T1	
F1	65-125	7,5	132M	65	163	189	396	748	340	160	180	250	140	110	200	160	14	T1	
F1	65-160	5,5	132S	65	147	189	360	696	380	180	200	280	150	130	260	220	14	T2	
F1	65-160	7,5	132M	65	147	189	396	732	380	180	200	280	150	130	260	220	14	T2	
F1	65-160	11	160M	65	147	226	466	839	380	180	200	280	150	130	260	220	14	T2	
F1	65-160	15	160M	65	147	226	466	839	380	180	200	280	150	130	260	220	14	T2	
F2	65-200	11	160M	65	132	226	466	824	475	225	250	300	155	145	260	220	14	T2	
F2	65-200	15	160M	65	132	226	466	824	475	225	250	300	155	145	260	220	14	T2	
F2	65-200	18,5	160M	65	132	226	466	824	475	225	250	300	155	145	260	220	14	T2	
F2	65-200	22	180M	65	132	226	519	877	475	225	250	300	155	145	260	220	14	T2	
F2	65-250	18,5	160L	65	132	226	466	824	475	225	250	345	180	165	260	220	14	T2	
F2	65-250	22	180M	65	132	226	519	877	475	225	250	345	180	165	260	220	14	T2	
F2	65-250	30	200L	65	132	226	555	920	475	225	250	345	180	165	320	270	18	T3	
F2	65-250	37	200L	65	132	226	555	920	475	225	250	345	180	165	320	270	18	T3	
F1	80-160	7,5	132M	80	162	189	396	747	425	200	225	295	160	135	260	220	14	T2	
F1	80-160	11	160M	80	162	226	466	854	425	200	225	295	160	135	260	220	14	T2	
F1	80-160	15	160M	80	162	226	466	854	425	200	225	295	160	135	260	220	14	T2	
F2	80-200	15	160M	80	152	226	466	844	475	225	250	315	170	145	260	220	14	T2	
F2	80-200	18,5	160M	80	152	226	466	844	475	225	250	315	170	145	260	220	14	T2	
F2	80-200	22	180M	80	152	226	519	897	475	225	250	315	170	145	260	220	14	T2	
F2	80-200	30	200L	80	159	226	555	940	475	225	250	315	170	145	320	270	18	T3	



Kalasanati.com

2900 rpm (2 Pole Motor)

FORM	Pump Type	MOTOR		DNe DNb mm	ECO SNL INSTALLATION DIMENSIONS (mm)													Base Plate (**)
		kW	IEC		A	W	Lm*	L*	H	h1	h2	G	g1	g2	ABxAB	KxK	øS	
F2	80-250	30	200L	80	184	246	555	985	560	280	280	375	195	180	320	270	18	T3
F2	80-250	37	200L	80	184	246	555	985	560	280	280	375	195	180	320	270	18	T3
F2	80-250	45	225M	80	184	248	625	1057	560	280	280	375	195	180	320	270	18	T3
F2	80-250	55	250M	80	189	294	753	1236	560	280	280	375	195	180	400	350	18	T4
F1	100-160	11	160M	100	224	226	466	916	475	175	300	370	200	170	320	270	18	T3
F1	100-160	15	160M	100	224	226	466	916	475	175	300	370	200	170	320	270	18	T3
F1	100-160	18,5	160M	100	224	226	466	916	475	175	300	370	200	170	320	270	18	T3
F1	100-160	22	180M	100	224	226	519	969	475	175	300	370	200	170	320	270	18	T3
F1	100-160	30	200L	100	224	226	555	1005	475	175	300	370	200	170	320	270	18	T3
F1	100-200	22	180M	100	202	244	519	965	550	250	300	350	190	160	260	220	14	T2
F1	100-200	30	200L	100	209	246	555	1010	550	250	300	350	190	160	320	270	18	T3
F1	100-200	37	200L	100	209	246	555	1010	550	250	300	350	190	160	320	270	18	T3
F1	100-200	45	225M	100	209	248	625	1082	550	250	300	350	190	160	320	270	18	T3
F2	100-250	37	200L	100	204	246	555	1005	580	280	300	380	205	175	320	270	18	T3
F2	100-250	45	225M	100	204	248	625	1077	580	280	300	380	205	175	320	270	18	T3
F2	100-250	55	250M	100	209	294	754	1257	580	280	300	380	205	175	400	350	18	T4
F2	100-250	75	280M	100	209	294	886	1389	580	280	300	380	205	175	400	350	18	T4
F2	100-250	90	280M	100	209	294	886	1389	580	280	300	380	205	175	400	350	18	T4

1450 rpm (4 Pole Motor)

FORM	Pump Type	MOTOR		DNe DNb mm	ECO SNL INSTALLATION DIMENSIONS (mm)													Base Plate (**)
		kW	IEC		A	W	Lm*	L*	H	h1	h2	G	g1	g2	ABxAB	KxK	øS	
F1	40-125	0,37	71M	40	109	136	222	467	300	140	160	210	110	100	170	130	14	T0
F1	40-125	0,55	80M	40	109	156	243	509	300	140	160	210	110	100	170	130	14	T0
F1	40-160	0,37	71M	40	103	136	222	462	340	160	180	245	130	115	170	130	14	T0
F1	40-160	0,55	80M	40	103	156	243	503	340	160	180	245	130	115	170	130	14	T0
F1	40-160	0,75	80M	40	103	156	243	503	340	160	180	245	130	115	170	130	14	T0
F2	40-200	0,55	80M	40	103	156	244	503	380	180	200	275	140	135	200	160	14	T1
F2	40-200	0,75	80M	40	103	156	244	503	380	180	200	275	140	135	200	160	14	T1
F2	40-200	1,1	90L	40	103	156	267	526	380	180	200	275	140	135	200	160	14	T1
F2	40-200	1,5	90L	40	103	156	267	526	380	180	200	275	140	135	200	160	14	T1
F1	50-125	0,37	71M	50	133	136	222	492	360	160	200	220	120	100	200	160	14	T1
F1	50-125	0,55	80M	50	133	156	243	533	360	160	200	220	120	100	200	160	14	T1
F1	50-125	0,75	80M	50	133	156	243	533	360	160	200	220	120	100	200	160	14	T1
F1	50-160	0,55	80M	50	138	156	244	538	340	160	180	255	135	120	170	130	14	T1
F1	50-160	0,75	80M	50	138	156	244	538	340	160	180	255	135	120	170	130	14	T0
F1	50-160	1,1	90L	50	138	156	267	561	340	160	180	255	135	120	170	130	14	T0
F2	50-200	1,1	90L	50	118	156	267	541	425	200	225	280	145	135	200	160	14	T0
F2	50-200	1,5	90L	50	118	156	267	541	425	200	225	280	145	135	200	160	14	T1
F2	50-200	2,2	100L	50	118	179	292	589	425	200	225	280	145	135	200	160	14	T1
F2	50-250	2,2	100L	50	117	179	292	588	475	225	250	340	175	165	260	220	14	T1
F2	50-250	3	100L	50	117	179	292	588	475	225	250	340	175	165	260	220	14	T2
F2	50-250	4	112M	50	117	179	336	632	475	225	250	340	175	165	260	220	14	T2
F1	65-125	0,37	71M	65	163	136	222	522	340	160	180	140	110	140	200	160	14	T2
F1	65-125	0,55	80M	65	163	156	244	563	340	160	180	140	110	140	200	160	14	T1
F1	65-125	0,75	80M	65	163	156	244	563	340	160	180	140	110	140	200	160	14	T1
F1	65-125	1,1	90L	65	163	156	266	585	340	160	180	140	110	140	200	160	14	T1
F1	65-160	0,75	80M	65	143	156	244	543	380	180	200	150	130	150	200	160	14	T1
F1	65-160	1,1	90L	65	143	156	267	566	380	180	200	150	130	150	200	160	14	T1
F1	65-160	1,5	90L	65	143	156	267	566	380	180	200	150	130	150	200	160	14	T1
F1	65-160	2,2	100L	65	143	179	292	614	380	180	200	150	130	150	200	160	14	T1
F2	65-200	1,1	90L	65	132	156	267	555	475	225	250	300	155	145	260	220	14	T2
F2	65-200	1,5	90L	65	132	156	267	555	475	225	250	300	155	145	260	220	14	T2
F2	65-200	2,2	100L	65	132	179	292	603	475	225	250	300	155	145	260	220	14	T2
F2	65-200	3	100L	65	132	179	292	603	475	225	250	300	155	145	260	220	14	T2
F2	65-250	2,2	100L	65	132	179	292	603	475	225	250	345	180	165	260	220	14	T2
F2	65-250	3	100L	65	132	179	292	603	475	225	250	345	180	165	260	220	14	T2
F2	65-250	4	112M	65	132	179	336	647	475	225	250	345	180	165	260	220	14	T2
F2	65-250	5,5	132M	65	132	189	396	717	475	225	250	345	180	165	260	220	14	T2
F2	65-315	5,5	132M	65	169	215	396	780	560	280	280	420	220	200	400	350	18	T4
F2	65-315	7,5	132M	65	169	215	396	780	560	280	280	420	220	200	400	350	18	T4
F2	65-315	11	160M	65	169	245	466	880	560	280	280	420	220	200	400	350	18	T4
F1	80-160	1,1	90L	80	158	156	267	581	425	200	225	295	160	135	200	160	14	T1
F1	80-160	1,5	90L	80	158	156	267	581	425	200	225	295	160	135	200	160	14	T1
F1	80-160	2,2	100L	80	158	179	292	629	425	200	225	295	160	135	200	160	14	T1
F2	80-200	1,5	90L	80	152	156	267	575	475	225	250	315	170	145	260	220	14	T2
F2	80-200	2,2	100L	80	152	179	292	623	475	225	250	315	170	145	260	220	14	T2
F2	80-200	3	100L	80	152	179	292	623	475	225	250	315	170	145	260	220	14	T2
F2	80-200	4	112M	80	152	179	336	667	475	225	250	315	170	145	260	220	14	T2



Kalasanati.com

1450 rpm (4 Pole Motor)

FORM	Pump Type	MOTOR		DNe DNb mm	ECO SNL INSTALLATION DIMENSIONS (mm)													Base Plate (**)
		kW	IEC		A	W	Lm*	L*	H	h1	h2	G	g1	g2	ABxAB	KxK	øS	
F2	80-250	3	100L	80	184	189	292	665	560	280	280	375	195	180	320	270	18	T3
F2	80-250	4	112M	80	184	189	336	709	560	280	280	375	195	180	320	270	18	T3
F2	80-250	5,5	132M	80	184	214	396	794	560	280	280	375	195	180	320	270	18	T3
F2	80-250	7,5	132M	80	184	214	396	794	560	280	280	375	195	180	320	270	18	T3
F2	80-315	5,5	132M	80	194	215	396	805	595	280	315	425	220	205	400	350	18	T4
F2	80-315	7,5	132M	80	194	215	396	805	595	280	315	425	220	205	400	350	18	T4
F2	80-315	11	160M	80	194	245	466	905	595	280	315	425	220	205	400	350	18	T4
F2	80-315	15	160M	80	194	245	466	905	595	280	315	425	220	205	400	350	18	T4
F1	100-160	1,5	90L	100	224	156	267	647	475	175	300	370	200	170	320	270	18	T3
F1	100-160	2,2	100L	100	224	179	292	695	475	175	300	370	200	170	320	270	18	T3
F1	100-160	3	100L	100	224	179	292	695	475	175	300	370	200	170	320	270	18	T3
F1	100-200	3	100L	100	202	189	292	683	550	250	300	350	190	160	260	220	14	T2
F1	100-200	4	112M	100	202	189	336	727	550	250	300	350	190	160	260	220	14	T2
F1	100-200	5,5	132M	100	202	214	396	812	550	250	300	350	190	160	260	220	14	T2
F2	100-250	4	112M	100	204	189	336	729	580	280	300	380	205	175	320	270	18	T3
F2	100-250	5,5	132M	100	204	214	396	814	580	280	300	380	205	175	320	270	18	T3
F2	100-250	7,5	132M	100	204	214	396	814	580	280	300	380	205	175	320	270	18	T3
F2	100-250	11	160M	100	204	244	466	914	580	280	300	380	205	175	320	270	18	T3
F2	100-315	7,5	132M	100	199	215	396	810	670	315	355	455	240	215	400	350	18	T4
F2	100-315	11	160M	100	199	245	466	910	670	315	355	455	240	215	400	350	18	T4
F2	100-315	15	160M	100	199	245	466	910	670	315	355	455	240	215	400	350	18	T4
F2	100-315	18,5	180M	100	199	245	519	963	670	315	355	455	240	215	400	350	18	T4
F1	125-200	4	112M	125	220	213	336	769	560	280	280	390	210	180	400	350	18	T4
F1	125-200	5,5	132M	125	220	238	396	854	560	280	280	390	210	180	400	350	18	T4
F1	125-200	7,5	132M	125	220	238	396	854	560	280	280	390	210	180	400	350	18	T4
F2	125-250	5,5	132M	125	220	239	396	854	630	315	315	410	215	195	400	350	18	T4
F2	125-250	7,5	132M	125	220	239	396	854	630	315	315	410	215	195	400	350	18	T4
F2	125-250	11	160M	125	220	269	466	954	630	315	315	410	215	195	400	350	18	T4
F2	125-250	15	160M	125	220	269	466	954	630	315	315	410	215	195	400	350	18	T4
F2	125-315	11	160M	125	200	240	396	835	710	355	355	490	260	230	400	350	18	T4
F2	125-315	15	160M	125	200	240	396	835	710	355	355	490	260	230	400	350	18	T4
F2	125-315	18,5	180M	125	200	270	519	988	710	355	355	490	260	230	400	350	18	T4
F2	125-315	22	180M	125	200	270	519	988	710	355	355	490	260	230	400	350	18	T4
F2	125-315	30	200L	125	200	272	555	1026	710	355	355	490	260	230	400	350	18	T4
F2	150-250	15	160L	150	220	290	466	974	710	355	355	470	250	220	400	350	18	T4
F2	150-250	18,5	180M	150	223	290	519	1032	710	355	355	470	250	220	400	350	18	T4
F2	150-250	22	180M	150	223	290	519	1032	710	355	355	470	250	220	400	350	18	T4

Installation Arrangements

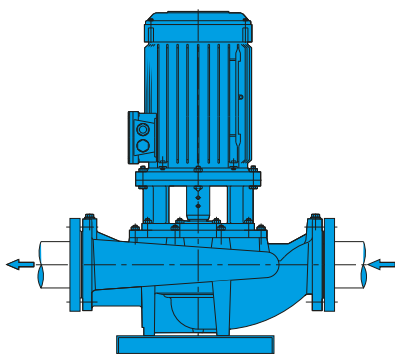

Standard installation type to horizontal pipe. (on ground)

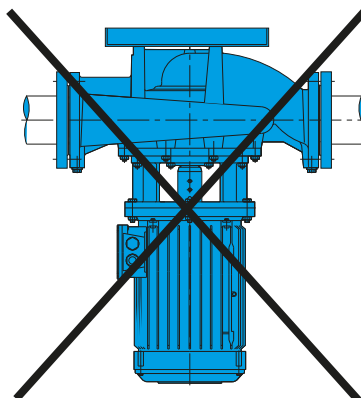

The axis of motor below the horizontal line is **not** admissible.

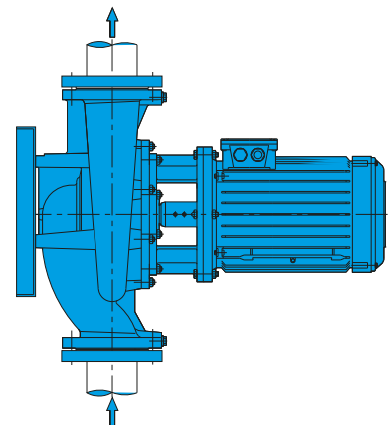

Please consult to Standart Pompa in case of installation to vertical pipes.



Assembly Drawings

Form: F1 (Slide - fit shaft application)

Kalasanati.com

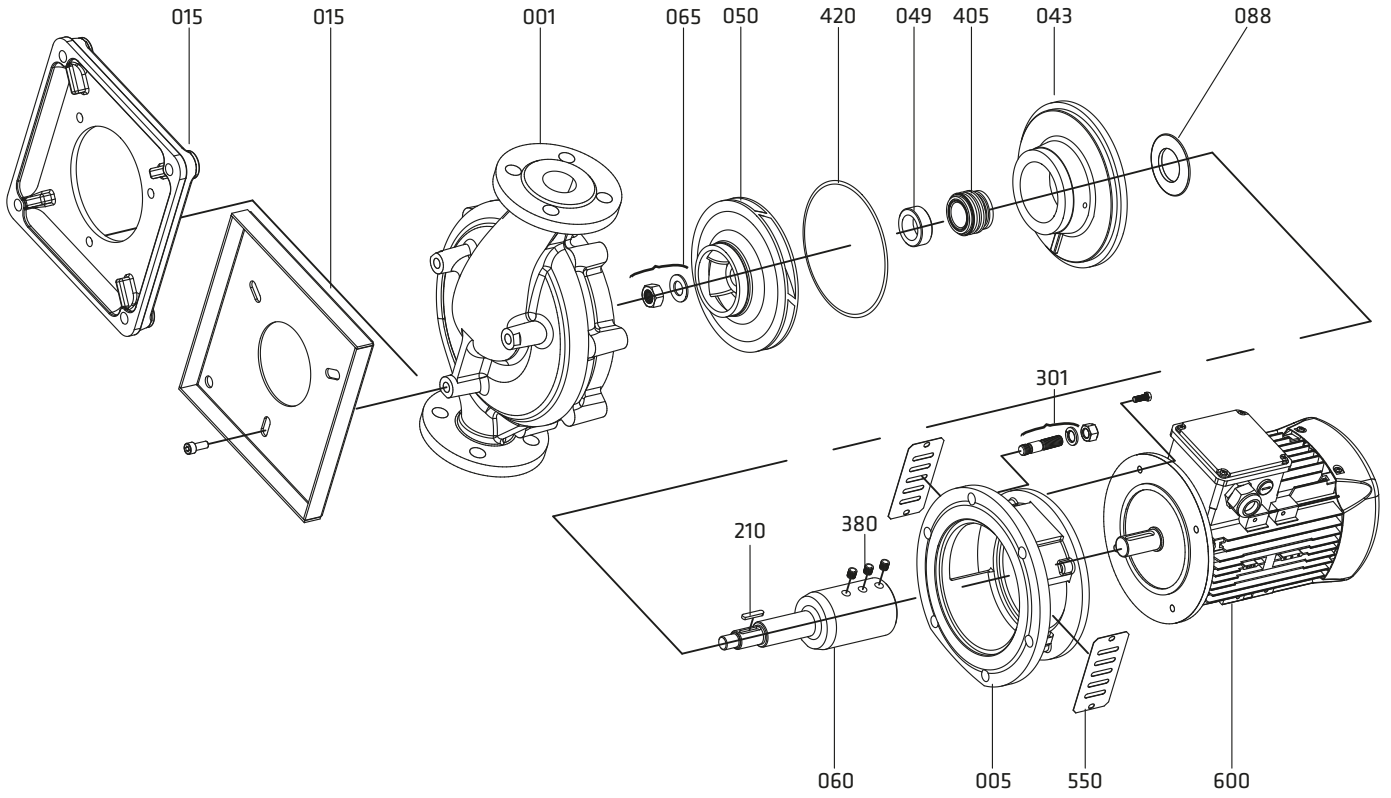

Form: F2 (Slide - fit shaft application)

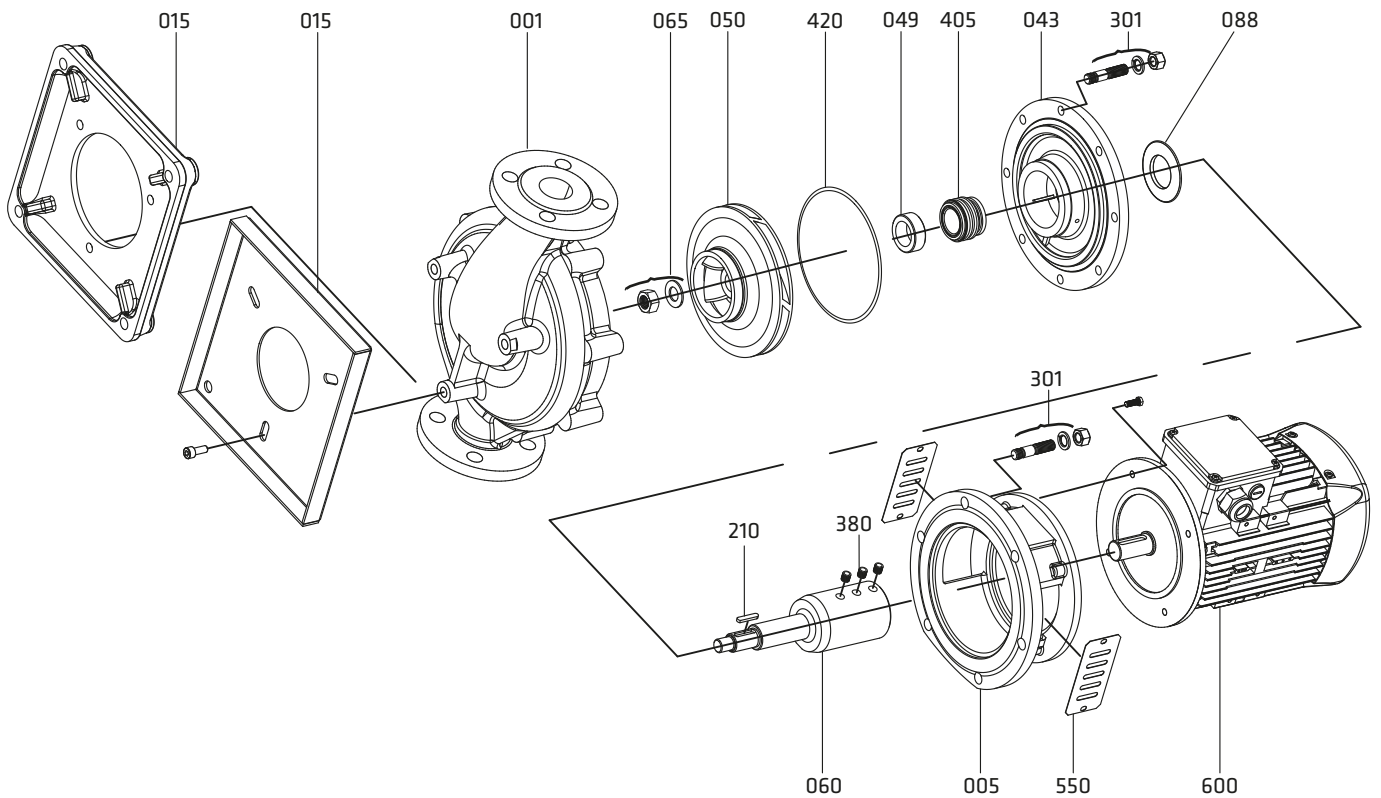

Rigid Coupling Application

For motor shaft diameters of Ø60 mm or bigger.

ECO SNL



Kalasanati.com

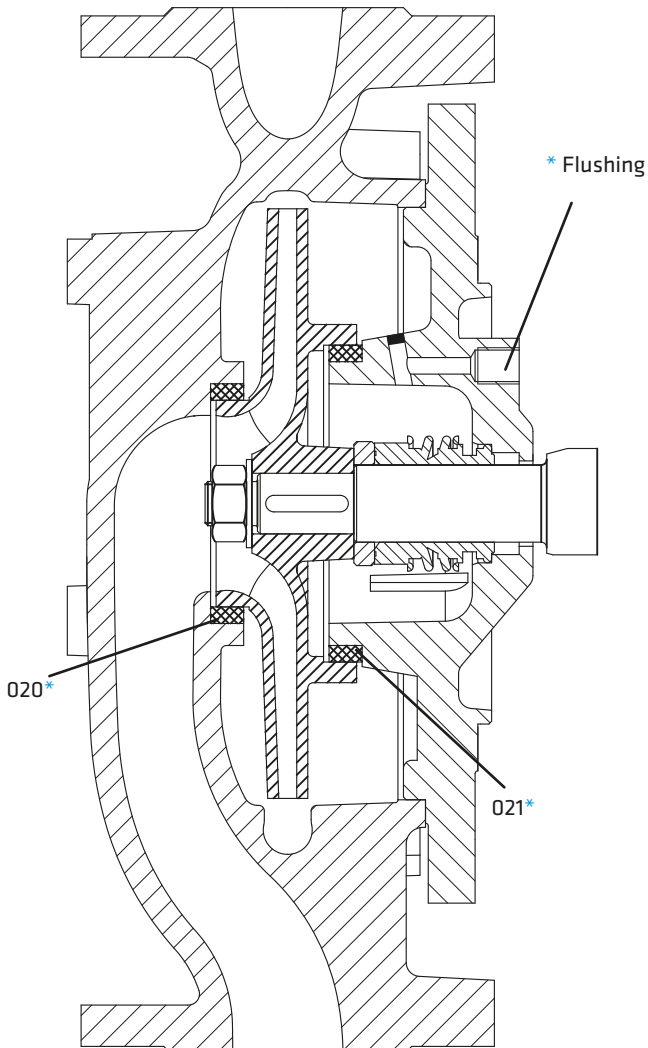
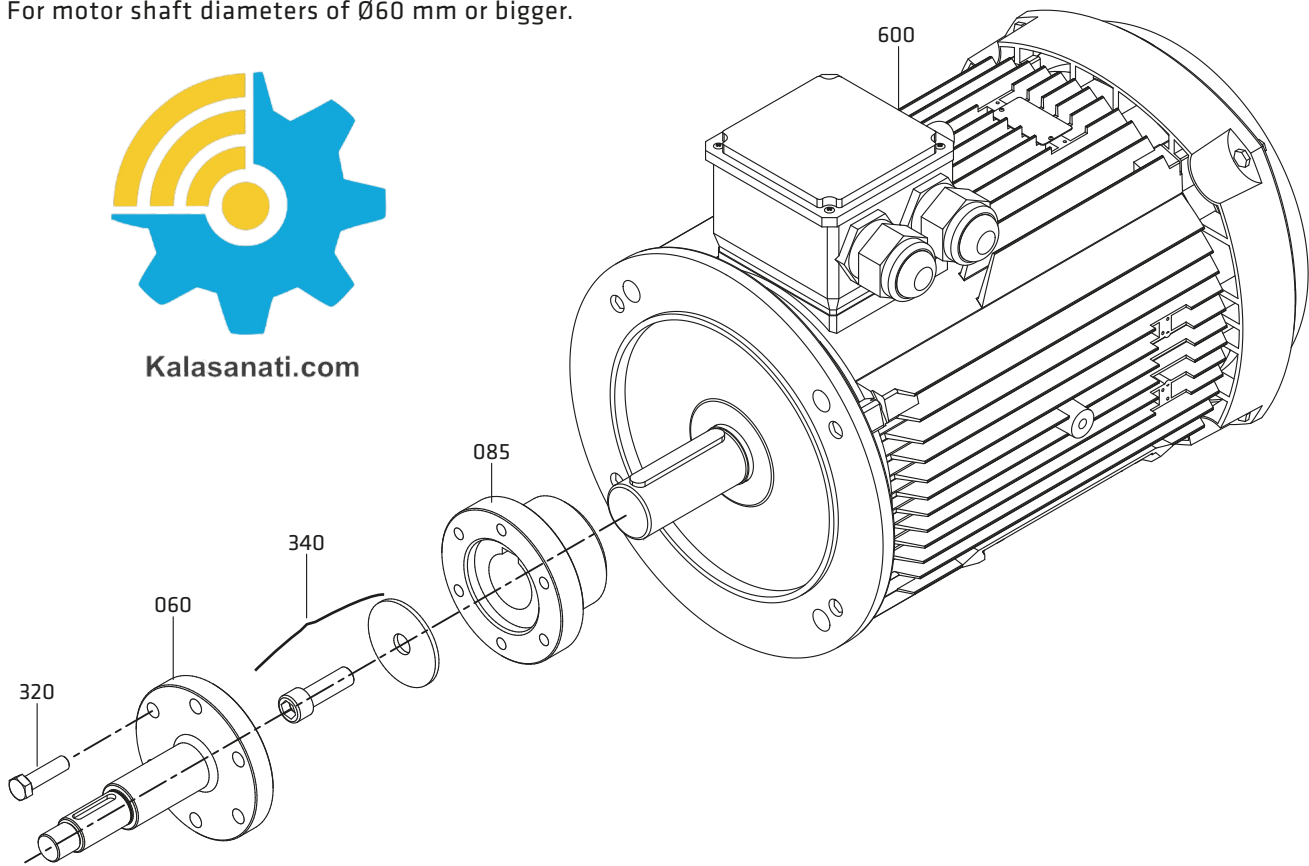

Part List

001	Volute Casing
005	Motor Pedestal
015	Bottom Plate
020*	Wear Ring (casing)
021*	Wear Ring (seal cover)
043	Mechanical Seal Cover
049	Mechanical Seal Spacer Sleeve
050	Impeller
060	Shaft
065	Impeller Nut and Washer
088	Thrower
093	Rigid Coupling
210	Impeller Key
230	Screw
301	Stud, Washer and Nut
320	Screw
340	Allen Screw and Washer
380	Set Screw
405	Mechanical Seal
420	O-ring
550	Guard
600	Electric Motor

(* Optional)



Kalasanati.com

Technical Data

ECO SNL

PART LIST	10	30	35	20	60	6L	70	7L	8M	7D	7S	8N	80	4C	4A	40	80	8T	60	7L	7E	7D	
	0.6025	0.7040	0.7043	1.0619	1.4308	1.4309	1.4408	1.4409	1.4500	1.4517	1.4469	1.4317	1.4008	2.1050.01	2.0975.01	2.1096.01	1.4021	1.4021+QT	1.4301	1.4404	1.4460	1.4462	
Volute Casing	●	○	○	○	○	○	○	○	○	○	○	○	○	○	○	○	○	○	○	○	○	○	○
Mechanical Seal Cover	●	○	○	○	○	○	○	○	○	○	○	○	○	○	○	○	○	○	○	○	○	○	○
Impeller	●	○	○	○	○	○	○	○	○	○	○	○	○	○	○	○	○	○	○	○	○	○	○
Shaft																	●	○	○	○	○	○	○
Motor Pedestal	●	○	○	○	○	○	○	○															
Wear Ring	○	○	○	○	○	○	○	○	○	○	○	○	○	○	○	○	○	○	○	○	○	○	○
Mech Seal Spacer Sleeve																	●	○	○	○	○	○	○
Mechanical Seal (*)	EN 12756																						
Bottom Plate	According to pump types, steel or cast iron material can be used. Contact company for non-standard application.																						

(*) Optional :Depending on customer requirement or request different types and brands of mechanical seals are applicable.

● Standard manufacturing

NOTE: Depends on the request, different than above casting and shaft material can be supplied.

○ Optional

Material Equivalents

Description	DIN / EN		AISI / SAE / ASTM
Cast Iron	0.6025	EN-GJL-250 (GG25)	A48 Class 40B
Nodular Cast Iron	0.7040	EN-GJS-400-15 (GGG40)	A536 60-40-18
Nodular Cast Iron	0.7043	EN-GJS-400-18-LT (GGG40.3)	A536 60-40-18
Cast Steel	1.0619	GP240GHGS-C25	A216 WCB
Chrome Nickel Cast Steel	1.4308	GX5CrNi19-10	A351 CF8
Chrome Nickel Cast Steel (low carbon)	1.4309	GX2CrNi19-11	A351 CF3
Chrome Nickel Molybdenum Cast Steel	1.4408	GX5CrNiMo19-11-2	A351 CF8M
Chrome Nickel Molybdenum Cast Steel (low carbon)	1.4409	GX2CrNiMo19-11-2	A351 CF3M
Austenitic Cast Steel	1.4500	GX7NiCrMoCuNb25-20	A351 CN7M
Austenitic - Ferritic Cast Steel (duplex)	1.4517	GX2CrNiMoCuN25-6-3-3	A890 CD4MCuN
Austenitic - Ferritic Cast Steel (super duplex)	1.4469	GX2CrNiMoN26-7-4	A890 CE3MN
Martenzitic Stainless Cast Steel	1.4317	GX4CrNi13-4	A352 CA6NM
Martenzitic Stainless Cast Steel	1.4008	GX7CrNiMo12-1	A217 CA15
Cast Bronze (tin alloy)	2.1050.01	G-CuSn10	B427 C90700
Cast Bronze (nickel alloy)	2.0975.01	G-CuAl10Ni	B148 C95500
Cast Bronze (Leaded)	2.1096.01	G-CuSn5ZnPb	B584 C83600
Chrome Steel	1.4021	X20Cr13	A276 Type 420
Chrome Steel(heat treated)	1.4021	X20Cr13	A276 Type 420+QT
Chrome Nickel Steel	1.4301	X5CrNi18-10	A276 Type 304
Chrome Nickel Steel (low carbon)	1.4404	X2CrNiMo17-12-2	A276 Type 316L
Duplex (austenitic-ferritic) Steel	1.4460	X3CrNiMoN27-5-2	AISI 329
Duplex (austenitic-ferritic) Steel	1.4462	X2CrNiMoN22-5-3	UNS S32205

Flange Dimensions

DNe/DNb	Suction & Discharge (PN 16)			
	Df	k	s	n
40	150	110	19	4
50	165	125	19	4
65	185	145	19	4
80	200	160	19	8
100	220	180	19	8
125	250	210	19	8
150	285	240	23	8
200	340	295	23	12

" n " number of holes

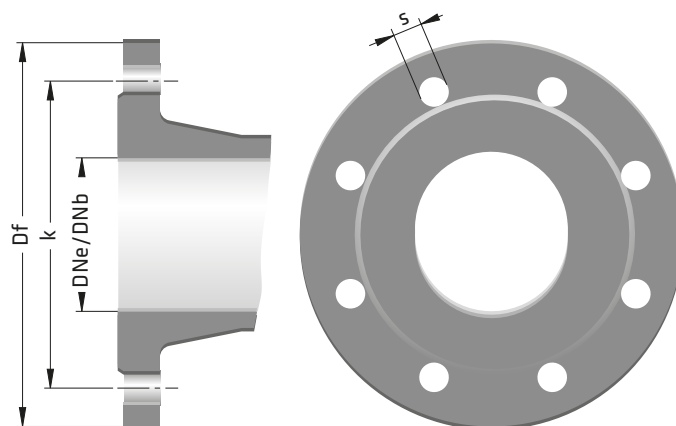



Pump • Fire Fighting Units • Booster Set

ECO SKY

THERMAL OIL PUMPS

Handled Liquids

Heat transfer oil or low viscosity industrial oil without aggressive solid particles.

Technical Data

Discharge Flange _____ DN 32.....DN 125 mm

Capacity _____ up to 500 m³/h*

Head _____ up to 105 m*

Design Temperature _____ up to 340 °C

Cooling Method _____ With Air

Casing Pressure (Pmax) _____ 10 bar (16 bar)**

(Pmax: Suction Pressure + Shut off Head)

(*) Contact company for higher capacity and head values.

(**) The Material of pump differs according to the type of pumped liquid, operating temperature and pressure. Contact for detailed information.

Design Features

- Horizontal, radially split volute casing type, single stage, end suction, air cooled centrifugal pumps with closed impeller.

- Suction and discharge flanges conform to EN 1092-2 / PN 16. For stainless steel casing, flanges are according EN 1092-1 / PN 16.

- Due to the back-pull-out design, the complete bearing assembly including impeller and casing cover can be dismantled without removing the volute casing from the pipe system. With spacer coupling application, also possible to take out the rotor group without dismantling the electric motor.



- All impellers are balanced dynamically according to ISO 1940 class 6.3.

- Axial thrust is balanced by impeller balancing holes system.

- Direction of rotation is clockwise viewed from drive end.

- Bearings of ECO SKY type pumps are “grease lubricated” ball bearings.

Shaft Sealing

- High temperature resistant mechanical seals are used.

Pressure & Temperature Limits

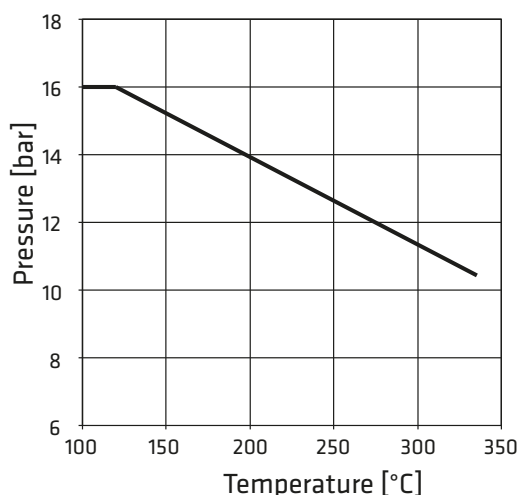

Pump Designation

Pump Type _____

Discharge Nozzle (DN-mm) _____

Nominal Impeller Diameter (mm) _____

ECO SKY 100 - 250



Kalasanati.com

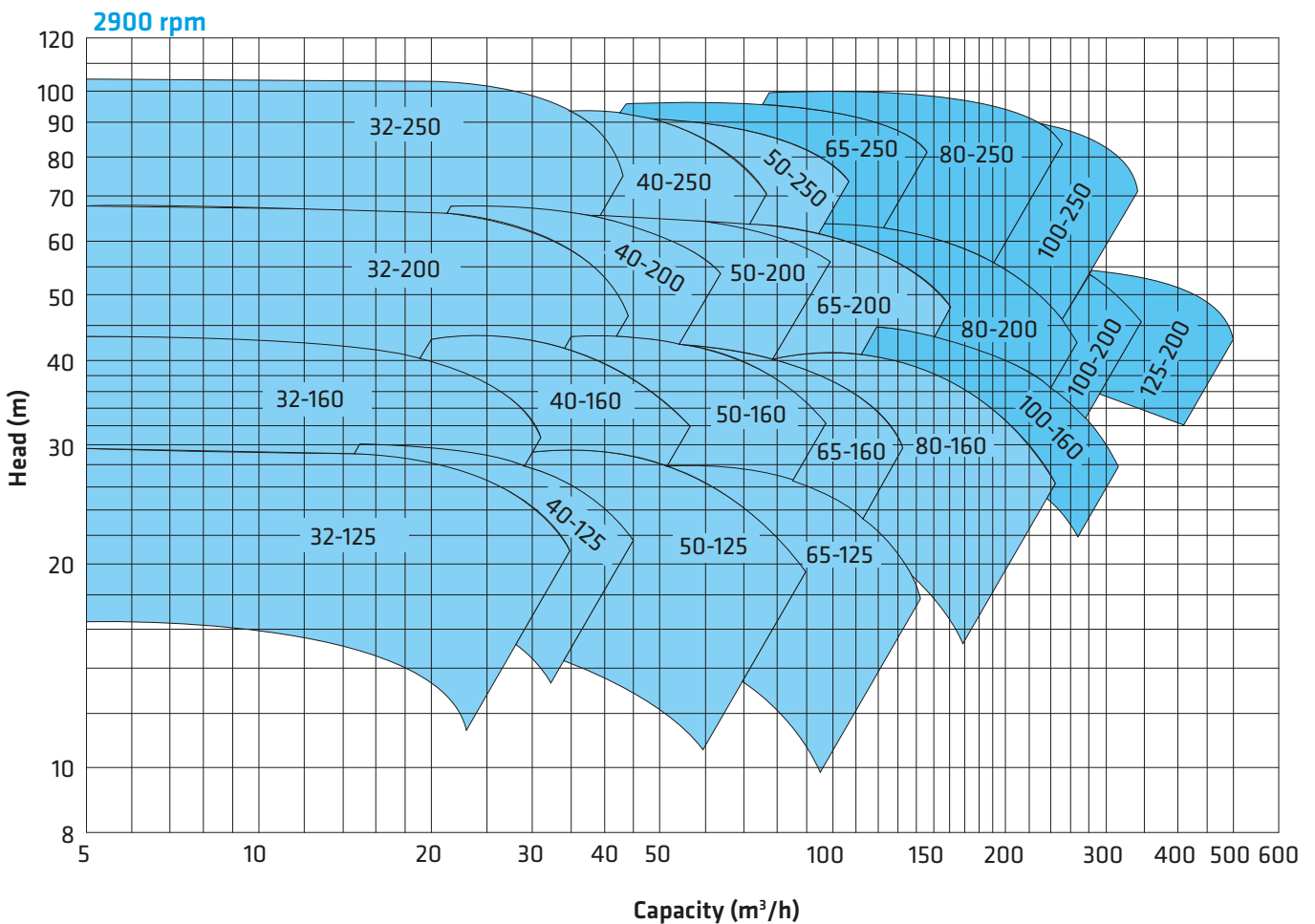
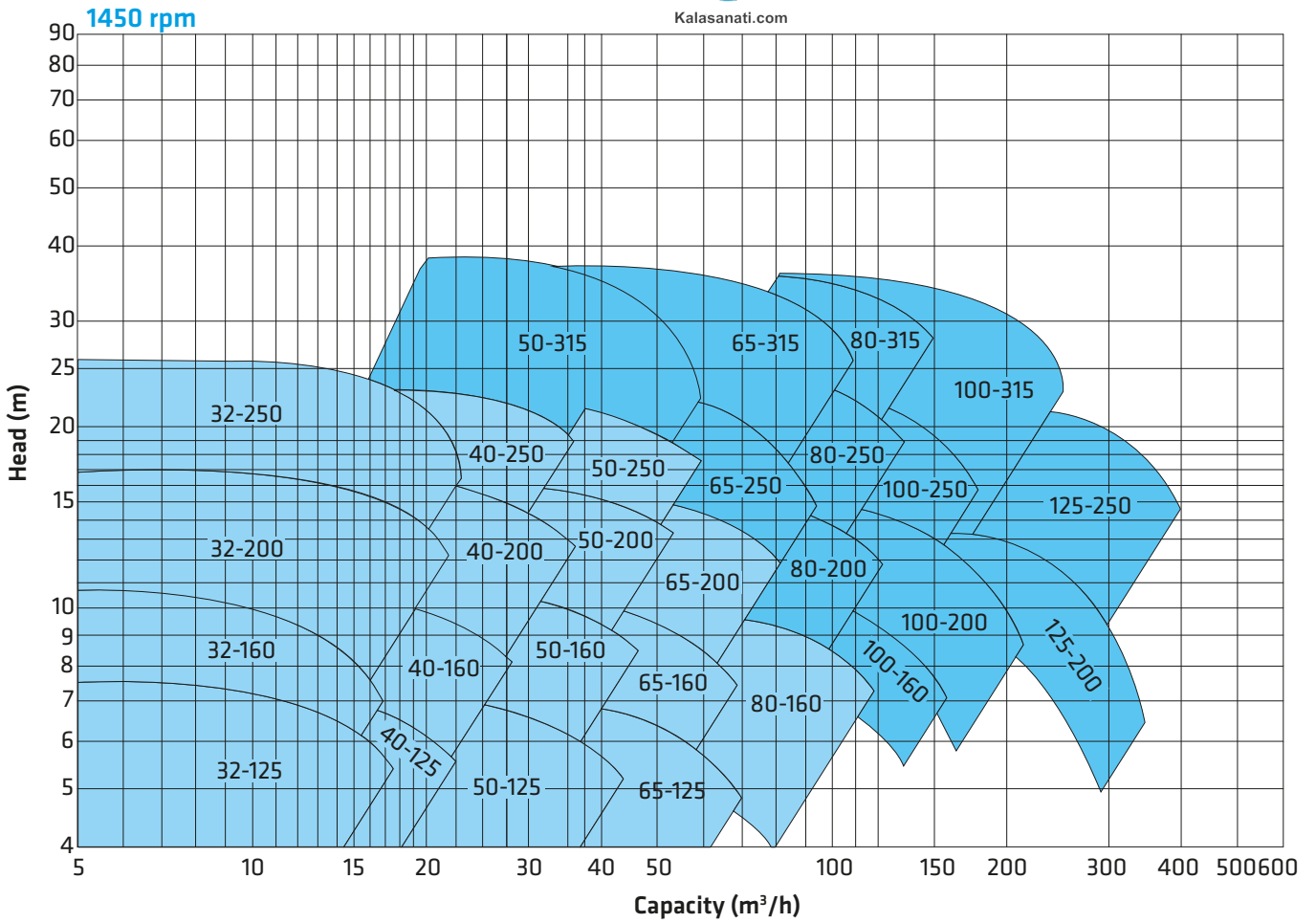

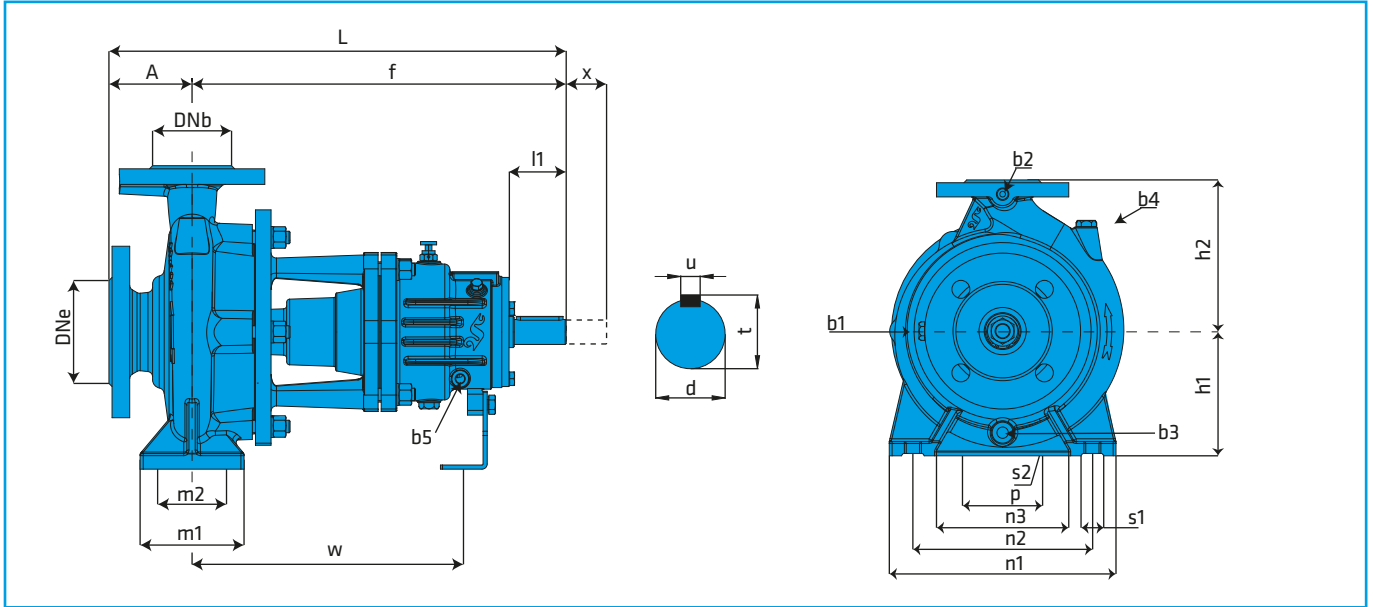

Pump Type		Overall Dimensions (mm)		Support & Foot Dimensions(mm)													Shaft End (mm)					Auxiliary Connections					Weight (kg)	Spacer x**
EN 733	Other	DN _e	DN _b	A	f	L	h ₁	h ₂	m ₁	m ₂	n ₁	n ₂	n ₃	s ₁	p	s ₂	w	d	l ₁	t	u	b ₁	b ₂	b ₃	b ₄	b ₅		
32-125		50	32	80	360	440	112	140	100	70	190	140	90	14	110	14	260	24	50	27	8	1/4"	1/4"	1/4"	1/4"	3/8"	32	100
32-160		50	32	80	360	440	132	160	100	70	240	190	140	14	110	14	260	24	50	27	8	1/4"	1/4"	1/4"	1/4"	3/8"	39	100
32-200		50	32	80	360	440	160	180	100	70	240	190	140	14	110	14	260	24	50	27	8	1/4"	1/4"	1/4"	1/4"	3/8"	41	100
	32-250	50	32	100	360	460	180	225	125	95	320	250	190	14	110	14	260	24	50	27	8	1/4"	1/4"	1/4"	1/4"	3/8"	53	100
40-125		65	40	80	360	440	112	140	100	70	210	160	110	14	110	14	260	24	50	27	8	1/4"	1/4"	1/4"	1/4"	3/8"	33	100
40-160		65	40	80	360	440	132	160	100	70	240	190	140	14	110	14	260	24	50	27	8	1/4"	1/4"	1/4"	1/4"	3/8"	40	100
40-200		65	40	100	360	460	160	180	100	70	265	212	165	14	110	14	260	24	50	27	8	1/4"	1/4"	1/4"	1/4"	3/8"	45	100
40-250		65	40	100	360	460	180	225	125	95	320	250	190	14	110	14	260	24	50	27	8	1/4"	1/4"	1/4"	1/4"	3/8"	57	100
50-125		65	50	100	360	460	132	160	100	70	240	190	140	14	110	14	260	24	50	27	8	1/4"	1/4"	1/4"	1/4"	3/8"	34	100
50-160		65	50	100	360	460	160	180	100	70	265	212	165	14	110	14	260	24	50	27	8	1/4"	1/4"	1/4"	1/4"	3/8"	42	100
50-200		65	50	100	360	460	160	200	100	70	265	212	165	14	110	14	260	24	50	27	8	1/4"	1/4"	1/4"	1/4"	3/8"	48	100
50-250		65	50	100	360	460	180	225	125	95	320	250	190	14	110	14	260	24	50	27	8	1/4"	1/4"	1/4"	1/4"	3/8"	57	100
	50-315	65	50	125	470	595	225	280	125	95	345	280	190	19	110	14	340	32	80	35	10	1/4"	1/4"	1/4"	1/4"	3/8"	90	100
65-125		80	65	100	360	460	160	180	125	95	280	212	150	14	110	14	260	24	50	27	8	1/4"	1/4"	3/8"	3/8"	3/8"	40	100
65-160		80	65	100	360	460	160	200	125	95	280	212	150	14	110	14	260	24	50	27	8	1/4"	1/4"	3/8"	3/8"	3/8"	46	100
65-200		80	65	100	360	460	180	225	125	95	320	250	190	14	110	14	260	24	50	27	8	1/4"	1/4"	3/8"	3/8"	3/8"	51	140
65-250		80	65	100	470	570	200	250	160	120	360	280	200	19	110	14	340	32	80	35	10	1/4"	1/4"	3/8"	3/8"	3/8"	90	140
65-315		80	65	125	470	595	225	280	160	120	400	315	240	19	110	14	340	32	80	35	10	1/4"	1/4"	3/8"	3/8"	3/8"	105	140
80-160		100	80	125	360	485	180	225	125	95	320	250	190	14	110	14	260	24	50	27	8	1/4"	1/4"	3/8"	3/8"	3/8"	49	140
80-200		100	80	125	470	595	180	250	125	95	345	280	215	14	110	14	340	32	80	35	10	1/4"	1/4"	3/8"	3/8"	3/8"	63	140
80-250		100	80	125	470	595	200	280	160	120	400	315	240	19	110	14	340	32	80	35	10	1/4"	1/4"	3/8"	3/8"	3/8"	95	140
80-315		100	80	125	470	595	250	315	160	120	400	315	240	19	110	14	340	32	80	35	10	1/4"	1/4"	3/8"	3/8"	3/8"	125	140
	100-160	125	100	125	470	595	200	280	160	120	360	280	200	19	110	14	340	32	80	35	10	1/4"	1/4"	3/8"	3/8"	3/8"	80	140
	100-200	125	100	125	470	595	200	280	160	120	360	280	200	19	110	14	340	32	80	35	10	1/4"	1/4"	3/8"	3/8"	3/8"	87	140
	100-250	125	100	140	470	610	225	280	160	120	400	315	240	19	110	14	340	32	80	35	10	1/4"	1/4"	3/8"	3/8"	3/8"	100	140
	100-315	125	100	140	470	610	250	315	160	120	400	315	240	19	110	14	340	32	80	35	10	1/4"	1/4"	3/8"	3/8"	3/8"	130	140
	125-200	150	125	140	470	610	250	315	160	120	400	315	240	19	110	14	340	32	80	35	10	1/4"	1/4"	1/2"	1/2"	3/8"	97	140
125-250		150	125	140	470	610	250	355	160	120	400	315	240	19	110	14	340	32	80	35	10	1/4"	1/4"	1/2"	1/2"	3/8"	110	140

(**) Gap necessary for the withdrawal of the pump rotor from the driven end without the need for dismantling the motor and pipework (spacer coupling application)



Kalasanati.com

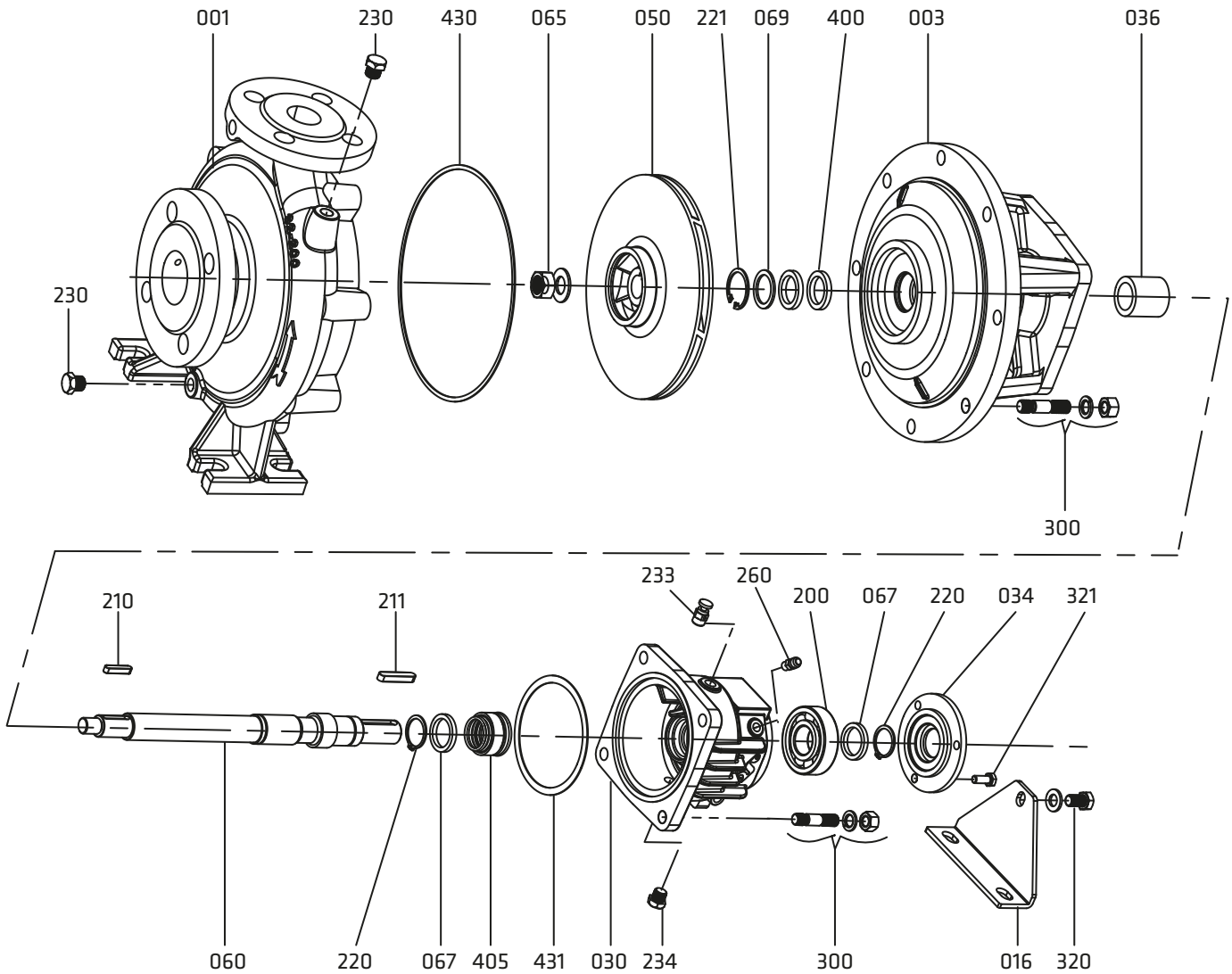

Part List

001	Volute Casing	221	Circlip
003	Casing Cover	230	Screw
016	Support Foot	233	Breather
030	Bearing Housing	234	Screw
034	Bearing Cover	260	Grease Nipple
036	Sleeve Bearing	300	Stud Bolt, Washer and Nut
050	Impeller	320	Screw
060	Shaft	321	Screw
065	Impeller Nut and Washer	400	Soft Packing
067	Spacer Sleeve	405	Mechanical Seal
069	Seal Sleeve	430	Gasket
200	Ball Bearing	431	Gasket
210	Impeller Key		
211	Coupling Key		
220	Circlip		



Material Equivalents

Description	DIN / EN		AISI / SAE / ASTM
Cast Iron	0.6025	EN-GJL-250 (GG25)	A48 Class 40B
Nodular Cast Iron	0.7040	EN-GJS-400-15 (GGG40)	A 536 Gr. 60-40-18
Chrome Nickel Moly. Cast Steel	1.4408	GX5CrNiMo19-11-2	A351 CF8M
Chrome Steel	1.4021	X20Cr13	A276 Type 420
Chrome Nickel Steel (low carbon)	1.4404	X2CrNiMo17-12-2	A276 Type 316L

Material Options

Part List	10	30	70	80	7L
	0.6025	0.7040	1.4408	1.4021	1.4404
Volute Casing		●	○		
Casing Cover		●	○		
Impeller	●	○	○		
Shaft				●	○
Bearing House		●	○		
Mechanical Seal	EN 12756				

● Standard manufacturing
○ Optional

Flange Dimensions

EN 1092 - 2	DNe/DNb	Suction & Discharge (PN 16)			
		Df	k	s	n
	32	140	100	19	4
	40	150	110	19	4
	50	165	125	19	4
	65	185	145	19	4
	80	200	160	19	8
	100	220	180	19	8
	125	250	210	19	8
	150	285	240	23	8

“ n “ number of holes



Kalasanati.com



ECO SNV

SUMP PUMP



Handled Liquids

Clean or normal contaminated low or medium viscosity liquids without solid & fibrous particles.

Technical Data

Discharge Flange _____ DN 32....DN 150 mm

Capacity _____ up to 400 m³/h

Head _____ up to 60 m

Speed _____ up to 1450 rpm

Design Temperature _____ up to +90 °C

Casing Pressure (Pmax) _____ 10 bar

Design Features

- Vertical, volute casing, single stage, end suction centrifugal sump pumps with enclosed type impeller.
- Up to 4 m. column length.
- Discharge pipe is extended up to base plate for easy installation.
- Suction and discharge flanges conform to EN 1092-2 / PN 16. (EN 1092-1 / PN 16 for steel or stainless steel casing)
- All impellers are balanced dynamically or statically according to ISO 1940 class 6.3.
- Axial thrust is balanced by impeller balancing holes system.

- Direction of rotation is clockwise viewed from driver.
- Bearings of ECO SNV type pumps are grease lubricated. Bottom and internal sleeve bearings are lubricated by the pumping liquid. (different lubrication systems can be applied for the sleeve bearings in case of request or requirement. Contact for detailed information)
- Discharge flange is screwed into the discharge pipe.
- Head is measured at the end of the volute casing discharge.

Shaft Sealing

- No sealing is required.

Pump Designation

Pump Type _____

Discharge Nozzle (DN-mm) _____

Nominal Impeller Diameter (mm) _____

ECO SNV 100 - 250

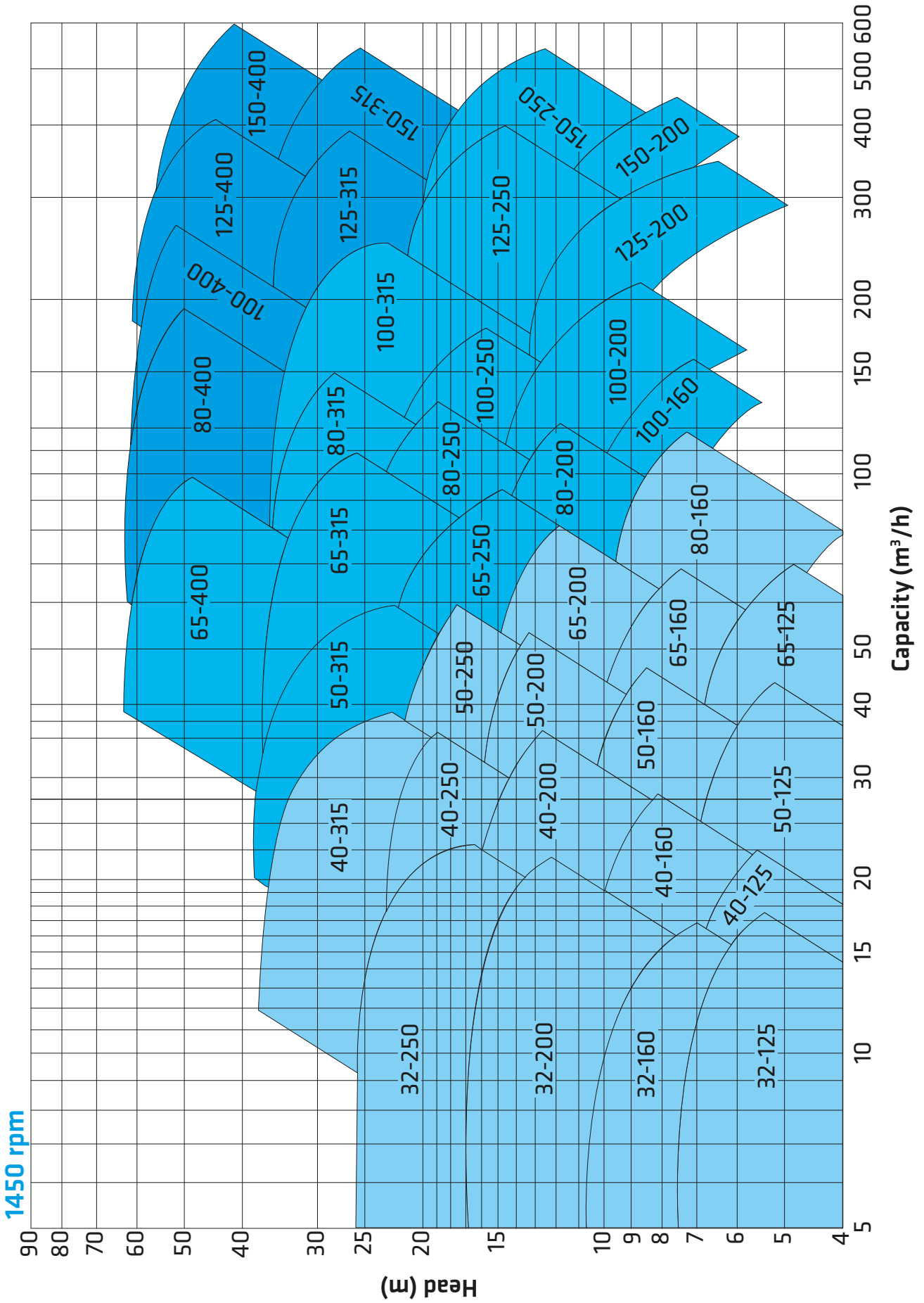



Kalasanati.com

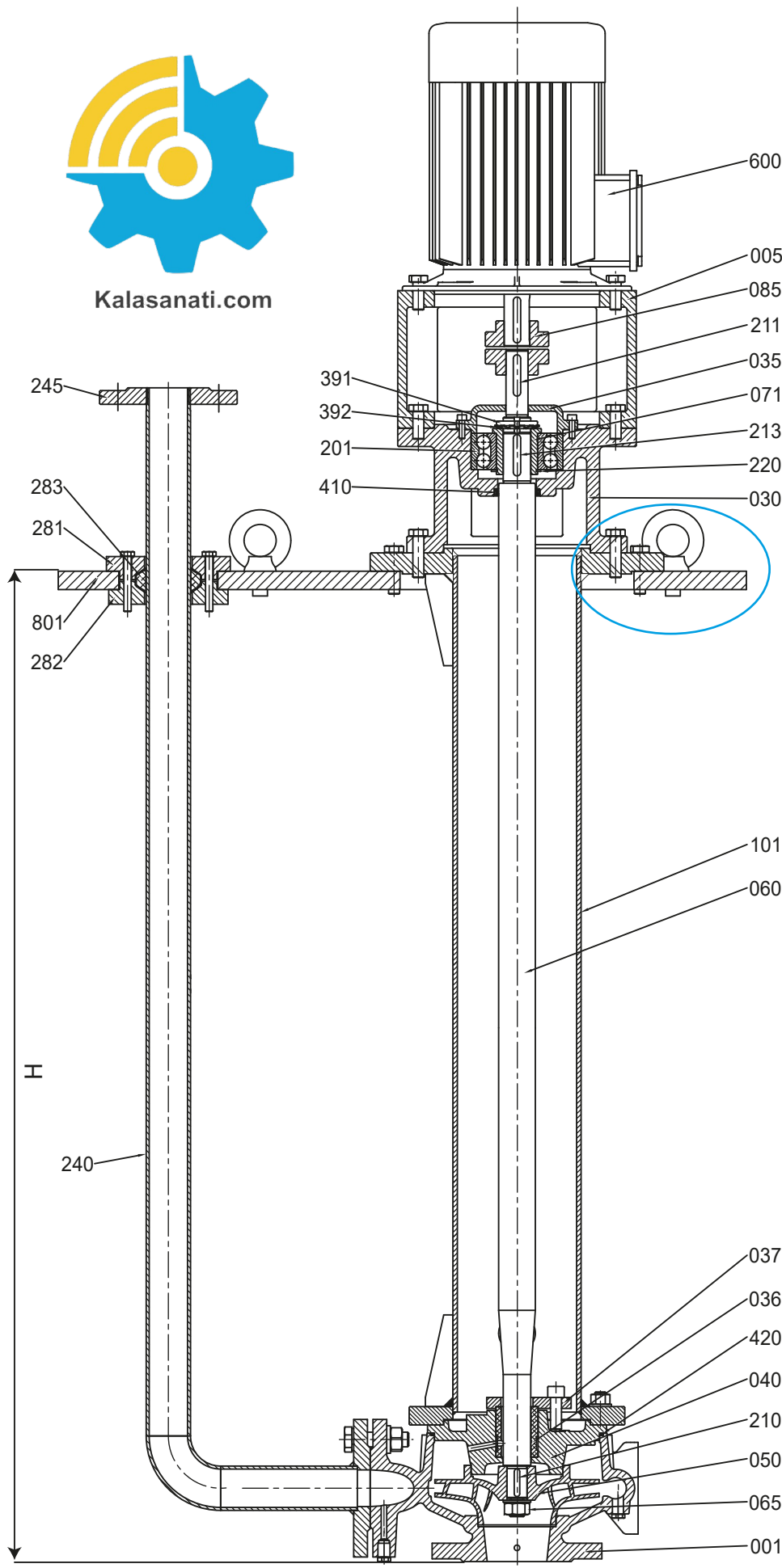

Part List

001	Volute Casing
003	Casing Cover
011	Motor Pedestal
030	Bearing Housing
035	Bearing Cover
036	Sleeve Bearing
037	Sleeve Bearing Cover
050	Impeller
060	Shaft
065	Impeller Nut
071	Intermediate Bearing Sleeve
085	Flexible Coupling
101	Column Pipe
201	Double Row Ball Bearing
210	Impeller Key
211	Coupling Key
213	Bearing Sleeve Key
220	Circlip
240	Discharge Pipe
245	Discharge Flange
281	Top Fixing Flange
282	Bottom Fixing Flange
283	Rubber Gasket
391	Shaft end nut
392	Lock Washer
410	Lip Seal
420	O-Ring
600	Electric Motor

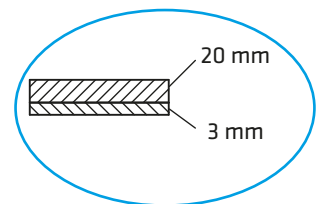

Optional
Stainless steel pump base plate
can be asked for stainless steel
pump as shown in the figure.

Sectional Drawing (Colum height greater than 1.5 m)

ECO SNV



Kalasanati.com

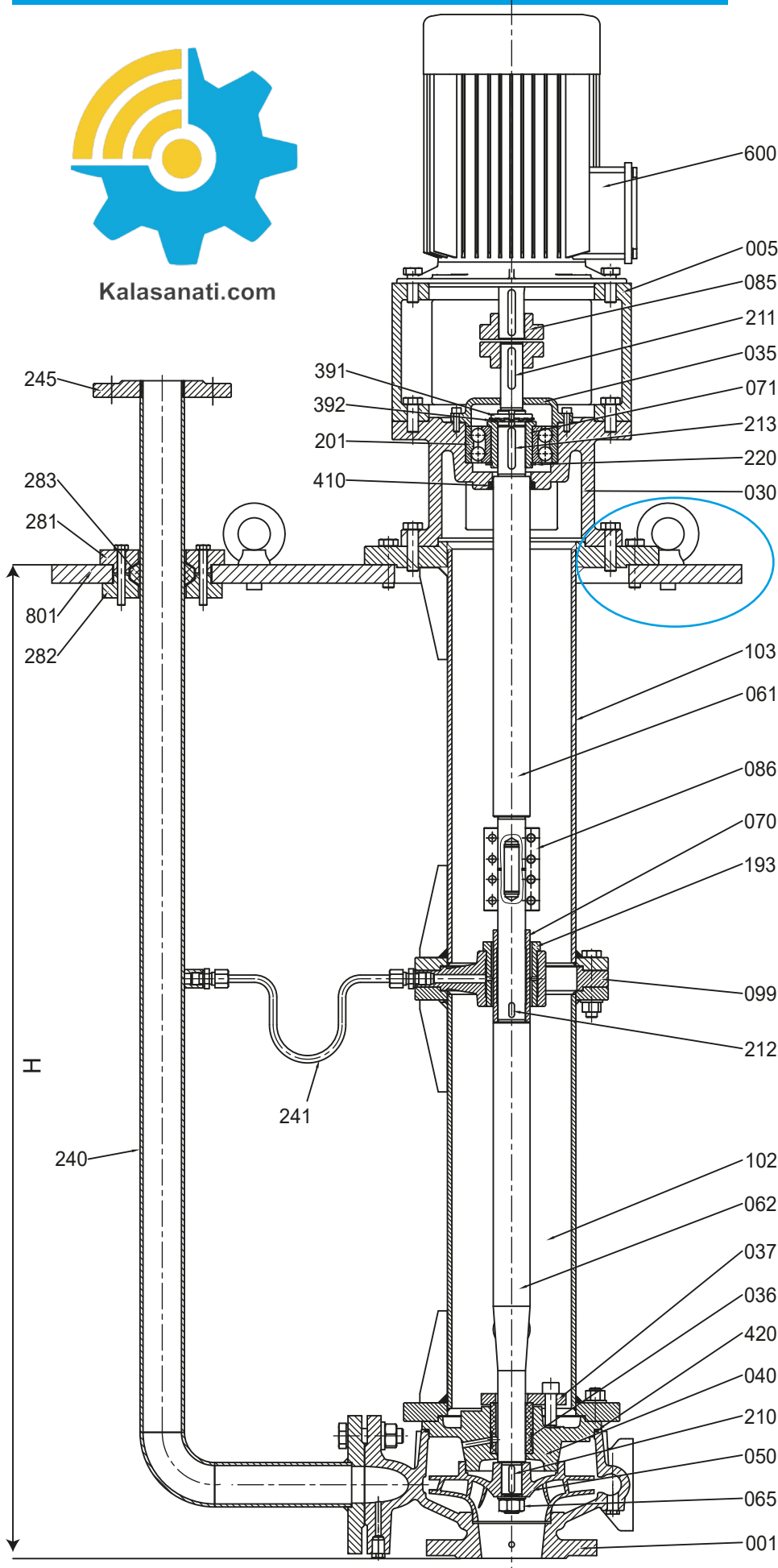

Part List

001	Volute Casing
005	Motor Pedestal
030	Bearing Housing
035	Bearing Cover
036	Sleeve Bearing
037	Sleeve Bearing Cover
040	Casing Cover
050	Impeller
061	Shaft (bottom)
062	Shaft (top)
065	Impeller Nut and Washer
070	Spacer Sleeve
071	Intermediate Bearing Sleeve
085	Flexible Coupling
086	Rigid Coupling
099	Intermediate Bearing Housing
102	Column Pipe (bottom)
103	Column Pipe (top)
193	Intermediate Sleeve Bearing
201	Double Row Ball Bearing
210	Impeller Key
211	Coupling Key
212	Spacer Sleeve Key
213	Bearing Sleeve Key
220	Circlip
240	Discharge Pipe
241	Cooling Pipe
245	Discharge Flange
281	Top Fixing Flange
282	Bottom Fixing Flange
283	Rubber Gasket
391	Shaft end nut
392	Lock Washer
410	Lip Seal
420	O-Ring
600	Electric Motor

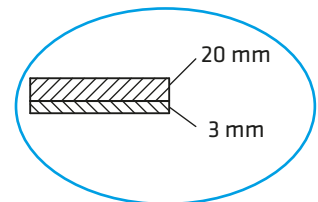

Optional
Stainless steel pump base plate
can be asked for stainless steel
pump as shown in the figure.



Technical Data

Kalasanati.com

PART LIST	0.6025	0.7040	1.0619	1.4308	1.4309	1.4408	1.4409	1.4500	1.4517	1.4469	1.4317	1.4008	2.1050.01	2.0975.01	2.1096.01	1.0037	1.0503	1.4021	1.4021+QT	1.4301	1.4404	1.4460	1.4462	Tungsten Carbide	
Volute Casing	●	○	○	○	○	○	○	○	○	○	○	○	○												
Casing Cover	●	○	○	○	○	○	○	○	○	○	○	○	○												
Impeller	●	○	○	○	○	○	○	○	○	○	○	○	○	○	○								○		
Shaft																	●	○	○	○	○			○	
Bearing Housing	●	○	○	○	○	○	○																		
Column Pipe																●				○	○				
Sleeve Bearing													●												○

● Standard manufacturing
○ Optional

Material Equivalents

Description	DIN / EN		AISI / SAE / ASTM
Cast Iron	0.6025	EN-GJL-250 (GG25)	A48 Class 40B
Nodular Cast Iron	0.7040	EN-GJS-400-15 (GGG40)	A536 60-40-18
Nodular Cast Iron	0.7043	EN-GJS-400-18-LT (GGG40.3)	A536 60-40-18
Cast Steel	1.0619	GP240GHGS-C25	A216 WCB
Chrome Nickel Cast Steel	1.4308	GX5CrNi19-10	A351 CF8
Chrome Nickel Cast Steel (low carbon)	1.4309	GX2CrNi19-11	A351 CF3
Chrome Nickel Molybdenum Cast Steel	1.4408	GX5CrNiMo19-11-2	A351 CF8M
Chrome Nickel Molybdenum Cast Steel (low carbon)	1.4409	GX2CrNiMo19-11-2	A351 CF3M
Austenitic Cast Steel	1.4500	GX7NiCrMoCuNb25-20	A351 CN7M
Austenitic - Ferritic Cast Steel (duplex)	1.4517	GX2CrNiMoCuN25-6-3-3	A890 CD4MCuN
Austenitic - Ferritic Cast Steel (super duplex)	1.4469	GX2CrNiMoN26-7-4	A890 CE3MN
Martenzitic Stainless Cast Steel	1.4317	GX4CrNi13-4	A352 CA6NM
Martenzitic Stainless Cast Steel	1.4008	GX7CrNiMo12-1	A217 CA15
Cast Bronze (tin alloy)	2.1050.01	G-CuSn10	B427 C90700
Cast Bronze (nickel alloy)	2.0975.01	G-CuAl10Ni	B148 C95500
Cast Bronze (lead)	2.1096.01	G-CuSn5ZnPb	B584 C83600
Steel	1.0037	St37	A 29 1015
Carbon Steel	1.0503	C45	AISI 1045
Chrome Steel	1.4021	X20Cr13	A276 Type 420
Chrome Steel (heat treated)	1.4021	X20Cr13	A276 Type 420+QT
Chrome Nickel Steel	1.4301	X5CrNi18-10	A276 Type 304
Chrome Nickel Steel (low carbon)	1.4404	X2CrNiMo17-12-2	A276 Type 316L
Duplex (austenitic-ferritic) Steel	1.4460	X3CrNiMoN27-5-2	AISI 329
Duplex (austenitic-ferritic) Steel	1.4462	X2CrNiMoN22-5-3	UNS S32205

Flange Dimensions

EN 1092 - 2

DNb	Discharge (PN 16)			
	Df	k	s	n
32	140	100	19	4
40	150	110	19	4
50	165	125	19	4
65	185	145	19	4
80	200	160	19	8
100	220	180	19	8
125	250	210	19	8
150	285	240	23	8

“ n “ number of holes





Pump • Fire Fighting Units • Booster Set

SNT NORM PUMPS



Kalasanati.com



Handled Liquids

Clean or slightly contaminated low viscosity liquids without solid & fibrous particles.

Technical Data

Discharge Flange _____ DN 150.....DN 250 mm

Capacity _____ up to 1500 m³/h

Head _____ up to 100 m

Speed _____ up to 1450 rpm

Design Temperature _____ -10 °C' to +140 °C*

Casing Pressure (Pmax) _____ 10 bar (16 bar)*

(Pmax: Suction Pressure + Shut off Head)

(*) The Material of pumps differ according to the type of pumped liquid, operating temperature and pressure. Contact for detailed information.

Design Features

•Horizontal , radially split volute casing type , single stage, end suction centrifugal pump with closed impeller.

•Suction and discharge flanges conform to EN 1092-2 / PN 16. (EN 1092-1 / PN 16 for steel or stainless steel casing)

•Due to the back-pull-out design, the complete bearing assembly including impeller and casing cover can be dismantled without removing the volute casing from the pipe system. (With spacer coupling application, also possible to take out the rotor group without dismantling the electric motor.)

•All impellers are balanced dynamically or statically according to ISO 1940 class 6.3.

•Axial thrust is balanced by impeller balancing holes system.

•Direction of rotation is clockwise viewed from drive end.

•Bearings of SNT type pumps are normally "life time grease lubricated" ball bearings, except the pumps SNT 200-500 and SNT 250-500 which are always oil lubricated.

Shaft Sealing

•In standard production soft packed stuffing boxes are used.

•Depending on customer request, mechanical seals are available. In this case, pump shaft is always stainless steel.

Pump Designation

SNT 150 - 500

Pump Type _____

Discharge Nozzle (DN-mm) _____

Nominal Impeller Diameter (mm) _____

02.2020 / Rev. 3



Kalasanati.com

SNT

Field Chart

1450 rpm

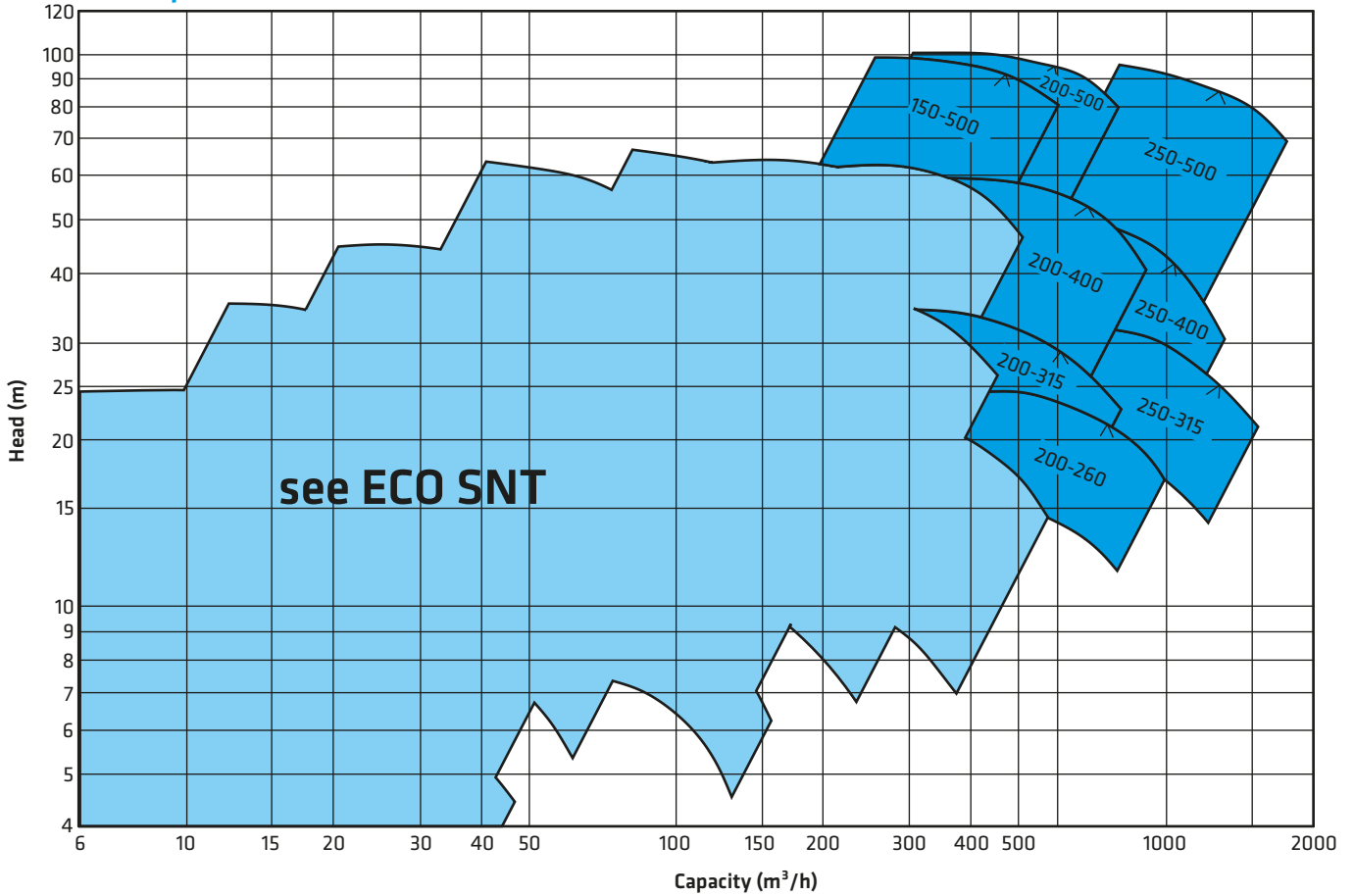

Technical Data

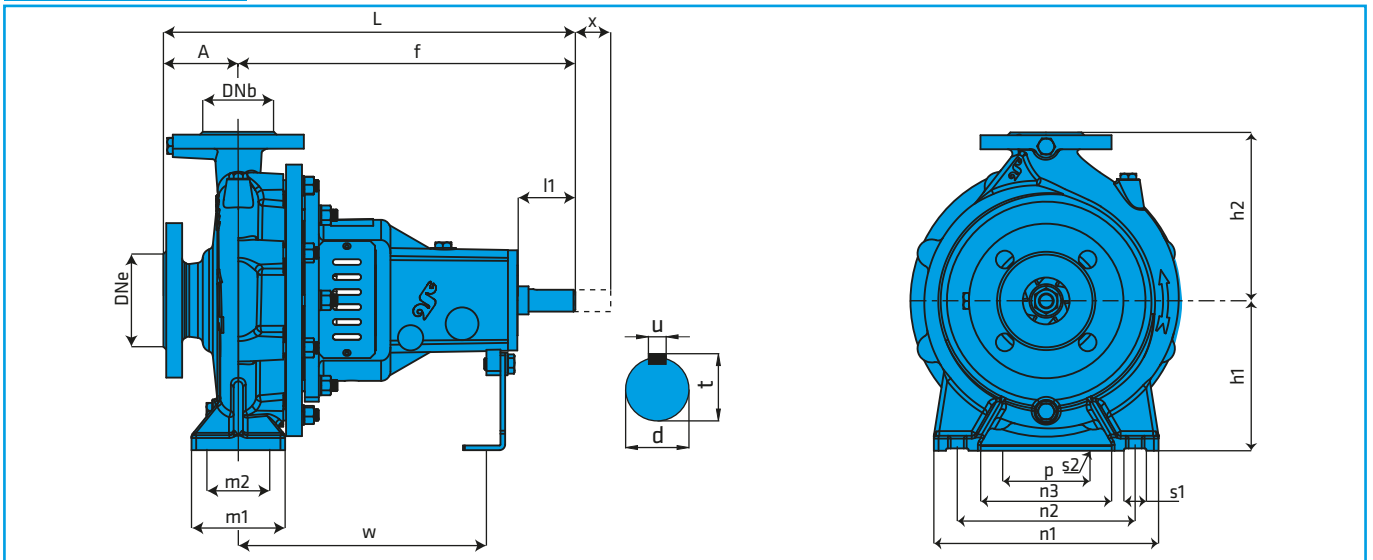

DIMENSIONS

Pump Type	Form	Overall Dimensions						Support & Foot Dimensions							Shaft End				Weight (kg)	Space x**			
		DNe	DNb	A	f	L	h1	h2	m1	m2	n1	n2	n3	s1	p	s2	w	d			l1	t	u
150-500	F2	200	150	200	730	930	400	525	250	200	720	600	435	27	140	20	495	55	110	59	16	480	140
200-260	F1	250	200	200	610	810	355	450	250	200	600	500	360	23	140	20	410	42	110	45	12	280	200
200-315	F1	250	200	200	610	810	355	450	250	200	600	500	360	23	140	20	410	42	110	45	12	300	180
200-400	F2	250	200	180	725	905	400	500	250	200	600	500	360	23	140	20	490	55	110	59	16	360	180
200-500	F3	250	200	210	925	1135	400	525	300	240	720	600	435	27	140	20	640	70	140	74.5	20	640	180
250-315	F1	300	250	230	740	970	400	525	300	240	720	600	435	27	140	20	520	55	110	59	16	390	200
250-400	F2	300	250	230	750	980	400	525	300	240	720	600	435	27	140	20	530	55	110	59	16	460	200
250-500	F3	300	250	225	940	1165	450	630	300	240	720	600	435	27	140	20	670	70	140	74.5	20	660	200

(**) Gap necessary for the withdrawal of the pump rotor from the driven end with out the need for dismantling the motor and pipework (spacer coupling application).

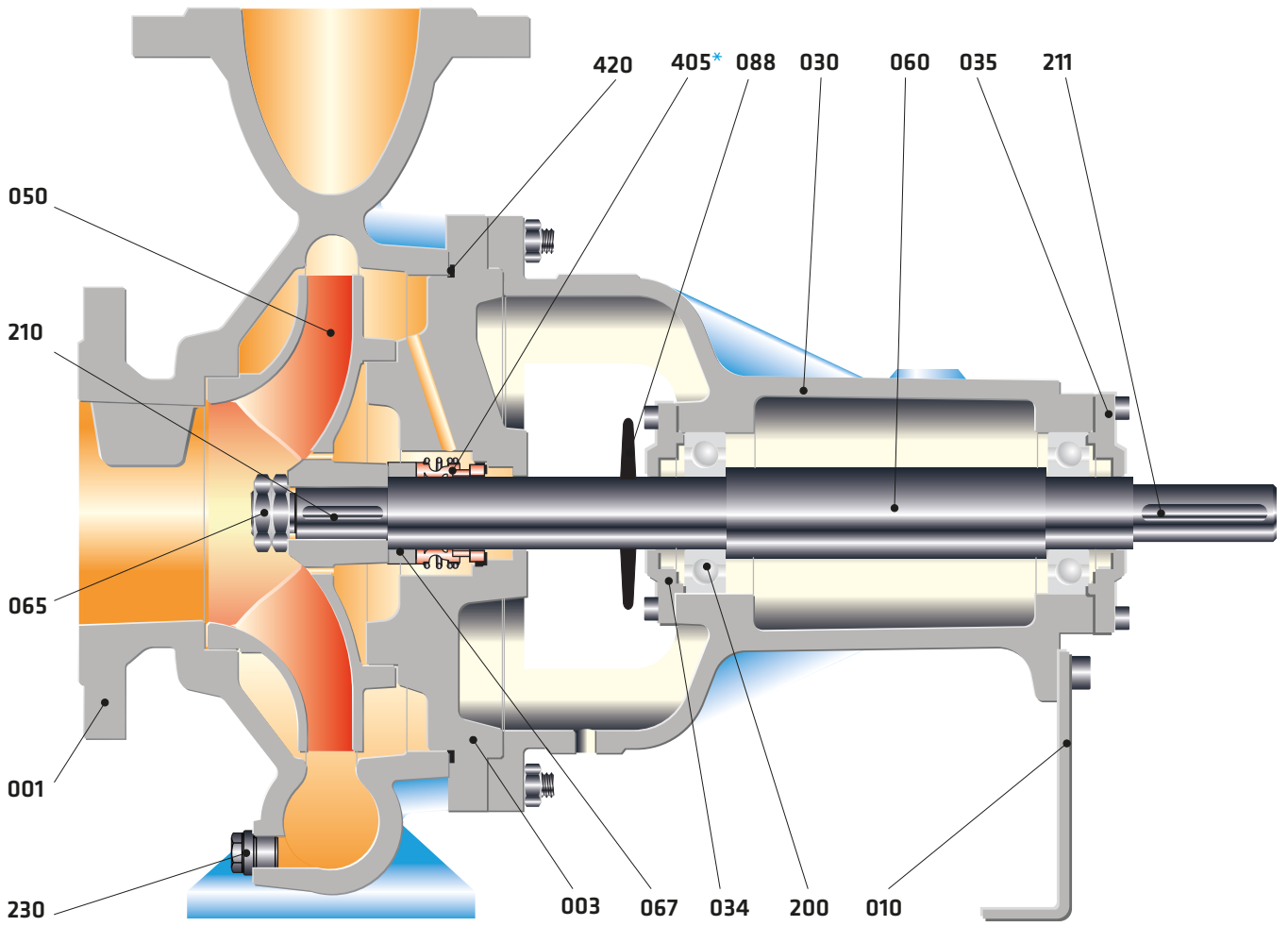

Form F1

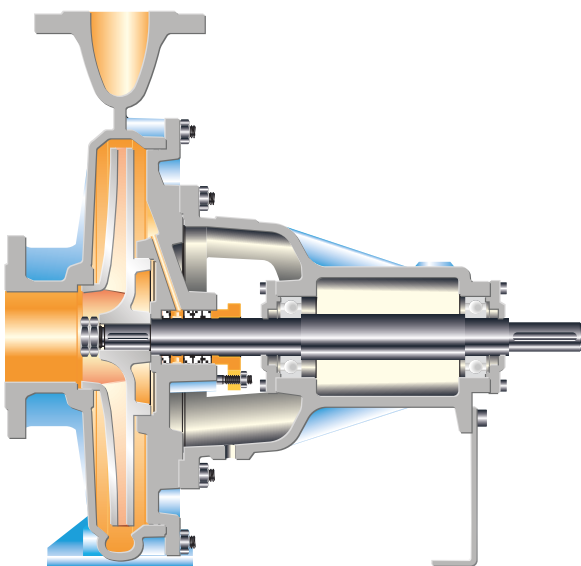

Form F2

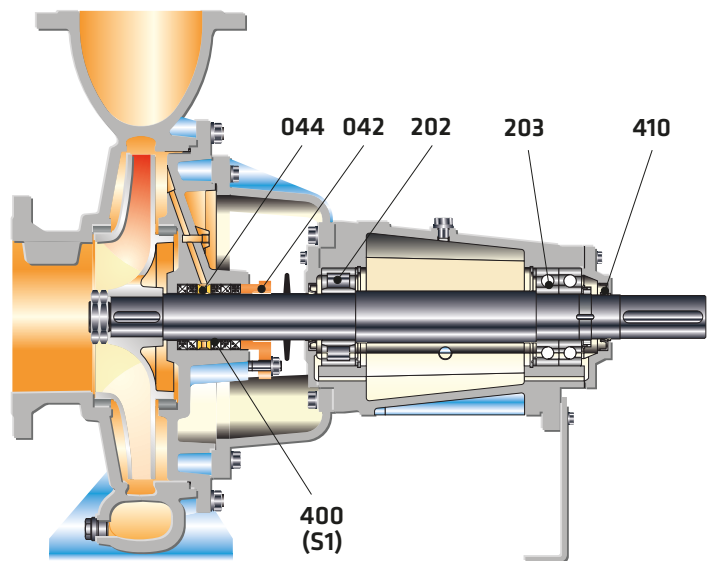

Form F3

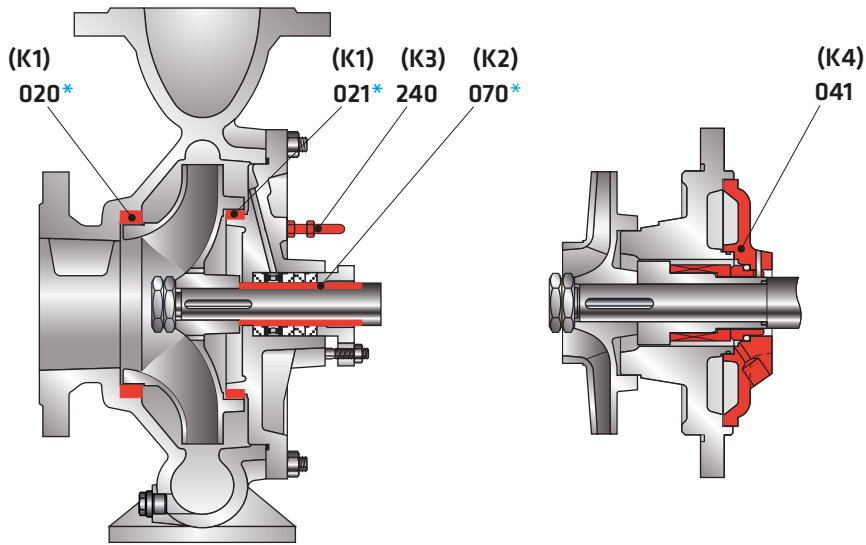

- (K1) Casing wear rings (front - back)
- (K2) Shaft sleeve
- (K3) Sealing fluid from outside source (for pumping contaminated and/or malodorous liquids)
- (K4) Stuffing box cooling (100 °C up to 140 °C)

Part List

001	Volute casing
003	Casing cover
010	Frame foot
020*	Wear ring (casing)
021*	Wear ring (casing cover)
030	Bearing housing
034	Bearing cover
035	Bearing cover
041	Cooling jacket
042	Gland
044	Lantern ring
048	Mechanical seal cover
050	Impeller
060	Pump shaft
065	Impeller nut
067	Spacer sleeve
070*	Shaft sleeve
088	Thrower
200	Ball bearing
202	Cylindrical roller bearing
203	Angular contact ball bearing
210	Impeller key
211	Coupling key
230	Drain plug
240	Seal tubing
400	Stuffing box packing
405*	Mechanical seal
410	Oil seal
420	O-Ring

(*) Optional

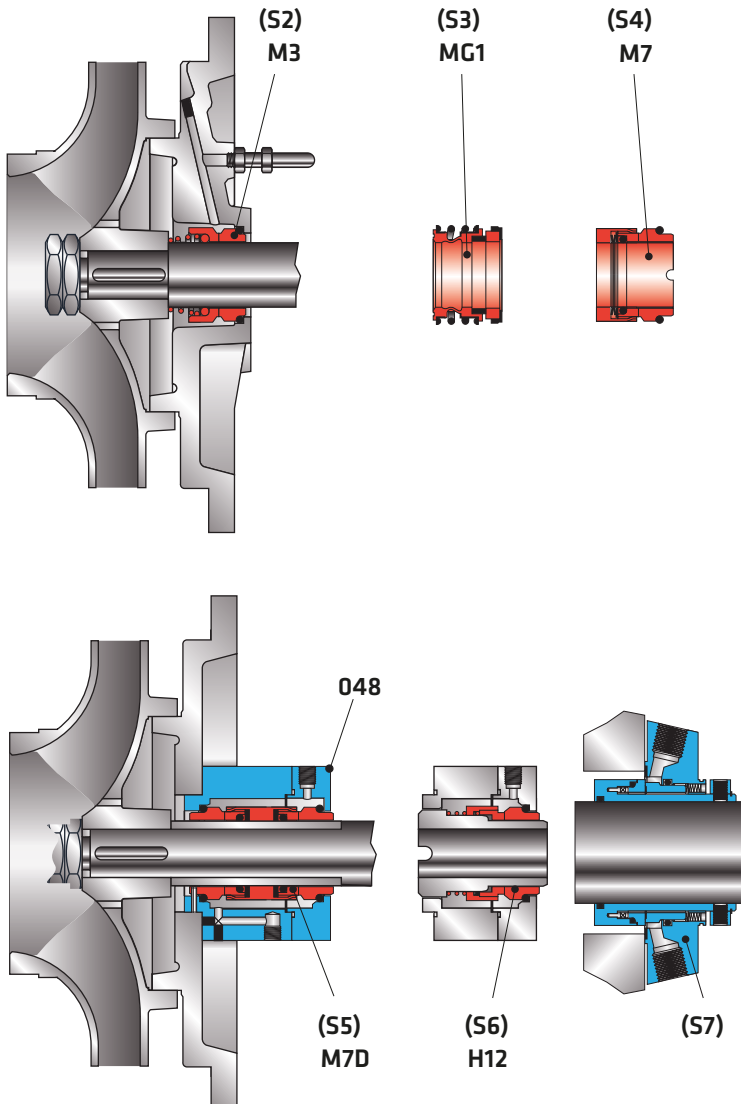

- (S1) Different soft packing types (up to 100 °C)
- (S2) M3 mechanical seal (up to 10 bar - 140 °C)
- (S3) MG1 mechanical seal (up to 12 bar - 140 °C)
- (S4) M7 mechanical seal (up to 16 bar - 140 °C)
- (S5) Double mechanical seal
- (S6) Balanced mechanical seal
- (S7) Cartridge mechanical seal

Technical Data

Part List	10	30	35	20	60	6L	70	7L	8M	7D	7S	8N	80	4C	4A	40	20	80	8T	60	7L	7E	7D	
	0.6025	0.7040	0.7043	1.0619	1.4308	1.4309	1.4408	1.4409	1.4500	1.4517	1.4469	1.4317	1.4008	2.1050.01	2.0975.01	2.1096.01	1.0503	1.4021	1.4021+QT	1.4301	1.4404	1.4460	1.4462	
Volute Casing	●	○	○	○	○	○	○	○	○	○	○	○	○	○	○	○	○	○	○	○	○	○	○	○
Casing Cover	●	○	○	○	○	○	○	○	○	○	○	○	○	○	○	○	○	○	○	○	○	○	○	○
Impeller	●	○	○	○	○	○	○	○	○	○	○	○	○	○	○	○	○	○	○	○	○	○	○	○
Shaft																	●	○	○	○	○	○	○	○
Bearing Housing	●	○	○	○	○	○	○	○																
Wear Ring	○	○	○	○	○	○	○	○	○	○	○	○	○	○	○	○	○	○	○	○	○	○	○	○
Shaft Sleeve																	○	○	○	○	○	○	○	○
Mechanical Seal (*)	EN 12756																							

(*) Optional :Depending on customer requirement or request different types and brands of mechanical seals are applicable.

● Standard manufacturing
○ Optional

Material Equivalents

Description	DIN / EN		AISI / SAE / ASTM
Cast Iron	0.6025	EN-GJL-250 (GG25)	A48 Class 40B
Nodular Cast Iron	0.7040	EN-GJS-400-15 (GGG40)	A536 60-40-18
Nodular Cast Iron	0.7043	EN-GJS-400-18-LT (GGG40.3)	A536 60-40-18
Cast Steel	1.0619	GP240GHGS-C25	A216 WCB
Chrome Nickel Cast Steel	1.4308	GX5CrNi19-10	A351 CF8
Chrome Nickel Cast Steel (low carbon)	1.4309	GX2CrNi19-11	A351 CF3
Chrome Nickel Molybdenum Cast Steel	1.4408	GX5CrNiMo19-11-2	A351 CF8M
Chrome Nickel Molybdenum Cast Steel (low carbon)	1.4409	GX2CrNiMo19-11-2	A351 CF3M
Austenitic Cast Steel	1.4500	GX7NiCrMoCuNb25-20	A351 CN7M
Austenitic - Ferritic Cast Steel (duplex)	1.4517	GX2CrNiMoCuN25-6-3-3	A890 CD4MCuN
Austenitic - Ferritic Cast Steel (super duplex)	1.4469	GX2CrNiMoN26-7-4	A890 CE3MN
Martenzitic Stainless Cast Steel	1.4317	GX4CrNi13-4	A352 CA6NM
Martenzitic Stainless Cast Steel	1.4008	GX7CrNiMo12-1	A217 CA15
Cast Bronze (tin alloy)	2.1050.01	G-CuSn10	B427 C90700
Cast Bronze (nickel alloy)	2.0975.01	G-CuAl10Ni	B148 C95500
Cast Bronze (Leaded)	2.1096.01	G-CuSn5ZnPb	B584 C83600
Carbon Steel	1.0503	C45	AISI 1045
Chrome Steel	1.4021	X20Cr13	A276 Type 420
Chrome Steel (Heat Treated)	1.4021	X20Cr13	A276 Type 420+QT
Chrome Nickel Steel	1.4301	X5CrNi18-10	A276 Type 304
Chrome Nickel Steel (low carbon)	1.4404	X2CrNiMo17-12-2	A276 Type 316L
Duplex (austenitic-ferritic) Steel	1.4460	X3CrNiMoN27-5-2	AISI 329
Duplex (austenitic-ferritic) Steel	1.4462	X2CrNiMoN22-5-3	UNS S32205

Flange Dimensions

EN 1092 - 2

DNe/DNb	Suction & Discharge (PN 16)			
	Df	k	s	n
32	140	100	19	4
40	150	110	19	4
50	165	125	19	4
65	185	145	19	4
80	200	160	19	8
100	220	180	19	8
125	250	210	19	8
150	285	240	23	8
200	340	295	23	12
250	405	355	28	12
300	460	410	28	12

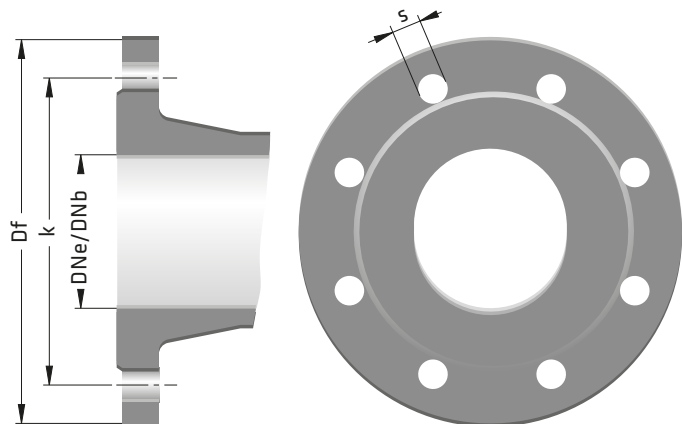

" n " number of holes



SNL

IN-LINE PUMPS



Handled Liquids

Clean or slightly contaminated low viscosity liquids without solid & fibrous particles.

Technical Data

Discharge Flange _____ DN 100.....DN 200 mm

Capacity _____ up to 500 m³/h

Head _____ up to 70 m

Speed _____ up to 1450 rpm

Motor Rating _____ up to 90 kW

Design Temperature _____ -10 °C' to +110 °C*

Casing Pressure (Pmax) _____ 10 bar (16 bar)*

(Pmax: Suction Pressure + Shut off Head)

(*) The Material of pumps differ according to the type of pumped liquid, operating temperature and pressure. Contact for detailed information.

Design Features

- Volute casing, single stage, rigidly coupled in-line centrifugal pump with closed impeller.

- Suction and discharge flanges conform to EN 1092-2 / PN 16. (EN 1092-1 / PN 16 for steel or stainless steel casing)

Pump Designation

Pump Type _____ **SNL**

Suction and Discharge Nozzle (DN-mm) _____ **100 - 250**

Nominal Impeller Diameter (mm) _____



- SNL pumps are rigidly coupled with electric motors of IEC frame sizes with high efficiency class.
- All impellers are balanced dynamically or statically according to ISO 1940 class 6.3.
- Axial thrust is balanced by impeller balancing holes system.
- The pump and motor have separate shafts connected by a rigid coupling and motor bearings absorb all pump axial thrust loads and radial load.
- Direction of rotation is clockwise viewed from drive end.

Shaft Sealing

- Single mechanical seal, flushed by pumped liquid, uncooled and unbalanced.

1450 rpm

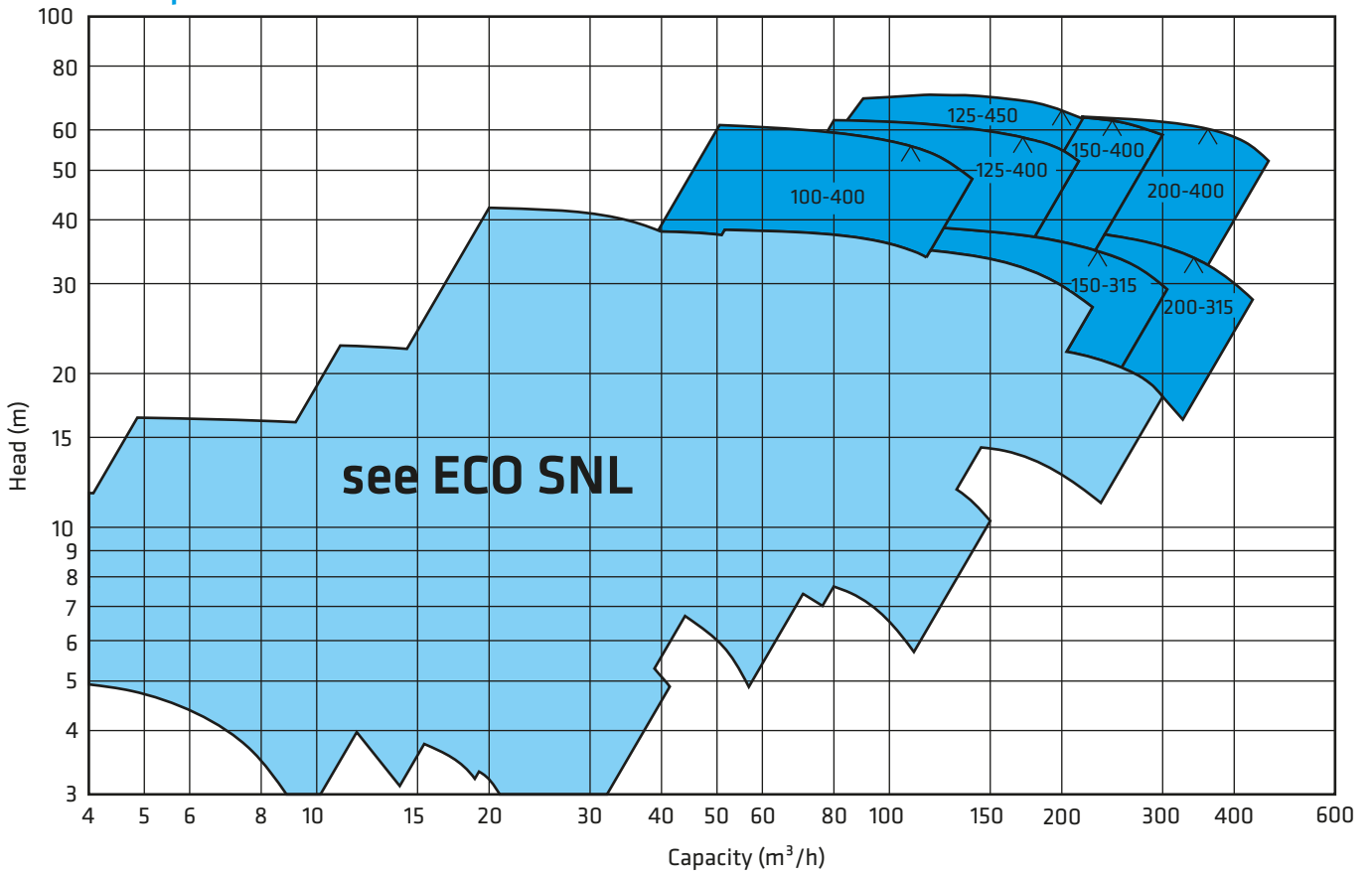

Installation Arrangements

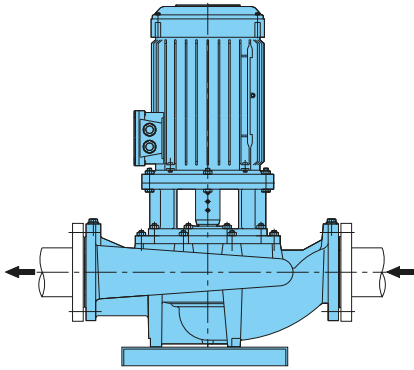

Standard installation type to horizontal pipe. (on ground)

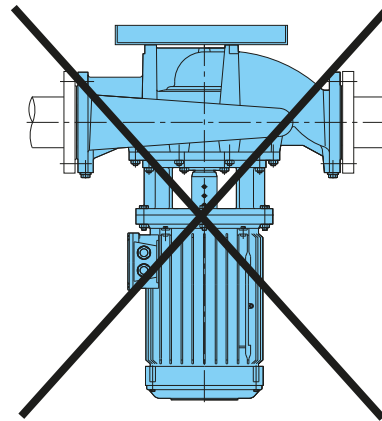

The axis of motor below the horizontal line is not admissible.



Kalasanati.com

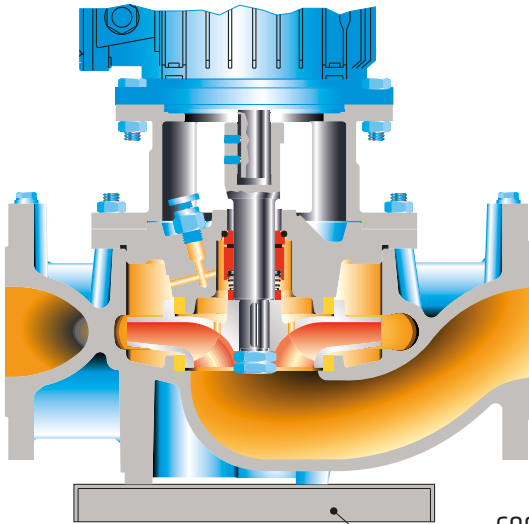

Form D1

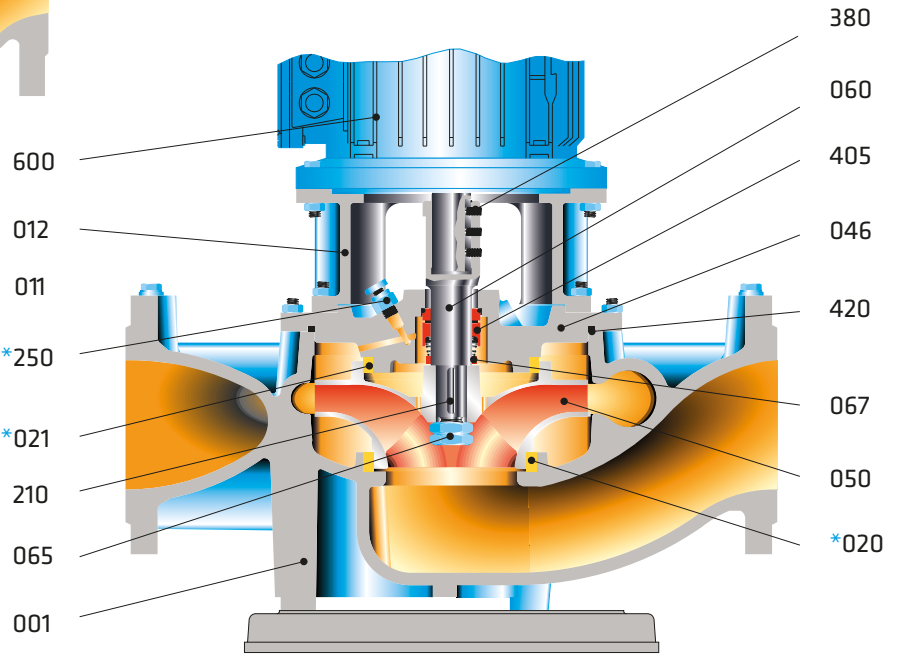

Form D2

Part List

- 001 Volute Casing
- 011 Base Plate (Foot)
- 012 Motor Pedestal
- *020 Wear Ring (Casing)
- *021 Wear Ring (Casing Cover)
- 046 Casing Cover
- 050 Impeller
- 060 Pump Shaft
- 065 Impeller Nut
- 067 Spacer Sleeve
- 085 Rigid Coupling
- 210 Impeller Key
- *250 Air Vent Screw
- 320 Hex. Head Bolt
- 340 Allen Bolt
- 370 Washer
- 380 Set-screw
- 405 Mechanical Seal
- 420 O-Ring
- 600 Electric Motor

(*) Optional

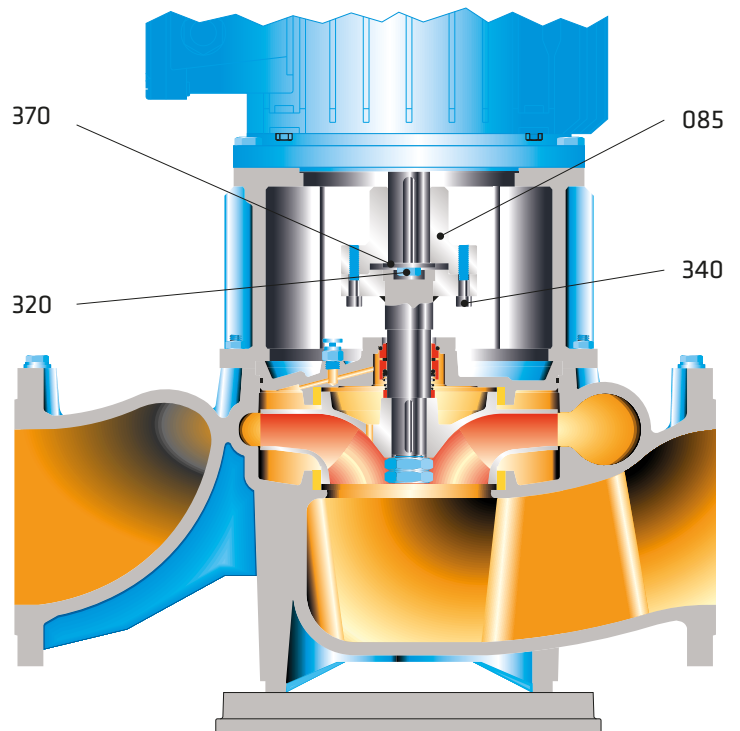

Form D3



Technical Data

Kalasanati.com

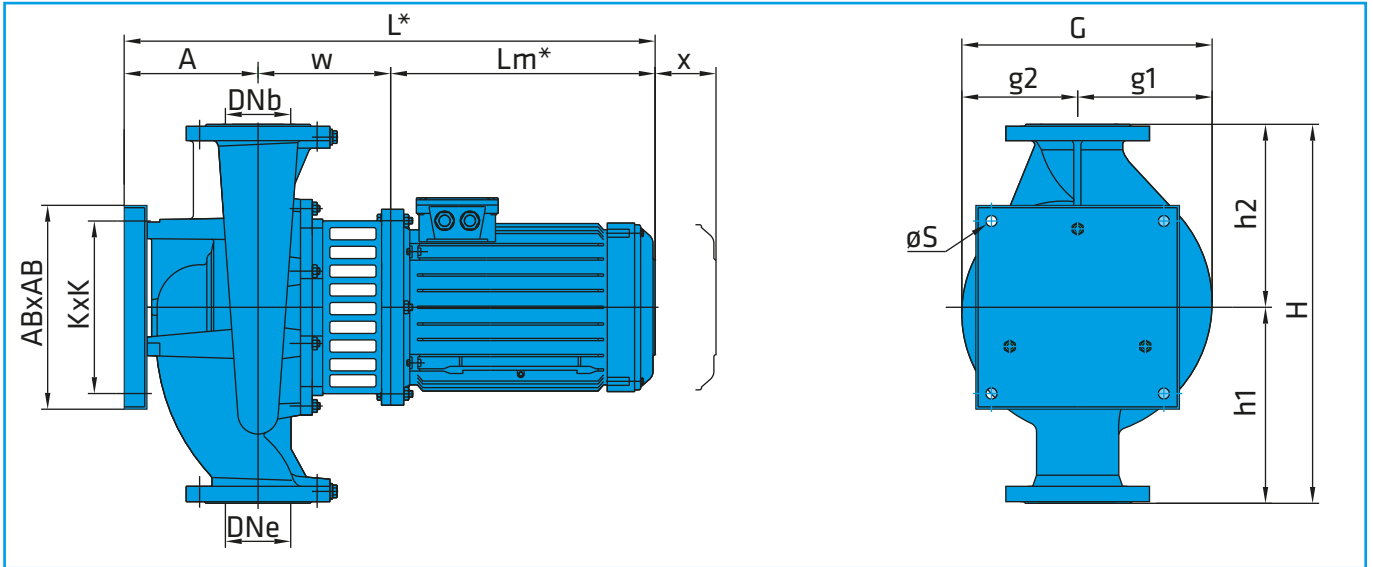

Technical Data

1450 rpm (4 Pole Motor)

FORM	Pump Type	MOTOR		DNe DNb mm	SNL DIMENSIONS (mm)*													Base Plate (**)	Weight (kg)*	
		kW	IEC		A	W	Lm	L	H	h1	h2	X	G	g1	g2	ABxAB	KxK			øS
D2	100-400	15	160L	100	190	255	476	921	800	400	400	160	558	288	270	400	350	18	T4	270
D2	100-400	18,5	180M	100	190	255	519	964	800	400	400	160	558	288	270	400	350	18	T4	293
D2	100-400	22	180L	100	190	255	519	964	800	400	400	160	558	288	270	400	350	18	T4	307
D3	100-400	30	200L	100	190	255	555	1000	800	400	400	160	558	288	270	400	350	18	T4	356
D3	100-400	37	225S	100	190	300	625	1115	800	400	400	160	558	288	270	400	350	18	T4	403
D2	125-400	22	180L	125	200	280	519	999	800	400	400	160	562	292	270	400	350	18	T4	336
D3	125-400	30	200L	125	200	280	555	1035	800	400	400	160	562	292	270	400	350	18	T4	385
D3	125-400	37	225S	125	200	325	625	1150	800	400	400	160	562	292	270	400	350	18	T4	432
D3	125-400	45	225M	125	200	325	625	1150	800	400	400	160	562	292	270	400	350	18	T4	469
D3	125-450	45	225M	125	205	325	625	1155	850	425	425	160	613	316	297	440	380	23	T5	574
D3	125-450	55	250M	125	205	325	644	1174	850	425	425	160	613	316	297	440	380	23	T5	594
D3	125-450	75	280M4	125	205	325	885	1415	850	425	425		613	316	293	440	380	23	T5	
D3	125-450	90	280M4	125	205	325	885	1415	850	425	425		613	316	293	440	380	23	T5	
D2	150-315	15	160L	150	225	315	476	1016	710	355	355	160	548	290	258	400	350	23	T5	290
D2	150-315	18,5	180M	150	225	315	519	1059	710	355	355	160	548	290	258	440	380	23	T5	319
D2	150-315	22	180L	150	225	315	519	1059	710	355	355	160	548	290	258	440	380	23	T5	327
D3	150-315	30	200L	150	225	315	555	1095	710	355	355	160	548	290	258	440	380	23	T5	376
D3	150-315	37	225S	150	225	360	625	1210	710	355	355	160	548	290	258	440	380	23	T5	423
D3	150-400	37	225S	150	225	360	625	1210	800	400	400	160	604	314	290	440	380	23	T5	483
D3	150-400	45	225M	150	225	360	625	1210	800	400	400	160	604	314	290	440	380	23	T5	520
D3	150-400	55	250M	150	225	360	644	1229	800	400	400	160	604	314	290	440	380	23	T5	540
D3	150-400	75	280M4	150	225	360	885	1470	800	400	400		604	314	290	440	380	23	T5	
D3	150-400	90	280M4	150	225	360	885	1470	800	400	400		604	314	290	440	380	23	T5	
D2	200-315	18,5	180M	200	245	355	519	1119	800	350	450	160	547	295	252	440	380	23	T5	384
D2	200-315	22	180L	200	245	355	519	1119	800	350	450	160	547	295	252	440	380	23	T5	392
D3	200-315	30	200L	200	245	355	555	1155	800	350	450	160	547	295	252	440	380	23	T5	441
D3	200-315	37	225S	200	245	385	625	1255	800	350	450	160	547	295	252	440	380	23	T5	488
D3	200-315	45	225M	200	245	385	625	1255	800	350	450	160	547	295	252	440	380	23	T5	522
D3	200-400	37	225S	200	245	400	625	1270	900	400	500	160	618	328	290	440	380	23	T5	493
D3	200-400	45	225M	200	245	400	625	1270	900	400	500	160	618	328	290	440	380	23	T5	527
D3	200-400	55	250M	200	245	400	644	1289	900	400	500	160	618	328	290	440	380	23	T5	550
D3	200-400	75	280M4	200	245	400	885	1530	900	400	500		618	328	290	440	380	23	T5	
D3	200-400	90	280M4	200	245	400	885	1530	900	400	500		618	328	290	440	380	23	T5	

1- (*) Dimensions and weights may change according to motor brand.

2- (**) Optional

3- Rights reserved to change without notice.

4- Base plate (foot) may differ for marine sector. Please consult to sales department for more information.



Kalasanati.com

SNL

Technical Data

Part List	10	30	35	20	60	6L	70	7L	8M	7D	7S	8N	80	4C	4A	40	80	8T	60	7L	7E	7D	
	0.6025	0.7040	0.7043	1.0619	1.4308	1.4309	1.4408	1.4409	1.4500	1.4517	1.4469	1.4317	1.4008	2.1050.01	2.0975.01	2.1096.01	1.4021	1.4021+QT	1.4301	1.4404	1.4460	1.4462	
Volute Casing	●	○	○	○	○	○	○	○	○	○	○	○	○	○	○	○							
Casing Cover	●	○	○	○	○	○	○	○	○	○	○	○	○	○	○	○							
Impeller	●	○	○	○	○	○	○	○	○	○	○	○	○	○	○	○						○	
Shaft																	●	○	○	○			○
Motor Pedestal	●	○	○	○	○	○	○	○															
Wear Ring	○	○	○	○	○	○	○	○	○	○	○	○	○	○	○	○							
Spacer Sleeve																	●	○	○	○			○
Mechanical Seal (*)	EN 12756																						

(*) Optional :Depending on customer requirement or request different types and brands of mechanical seals are applicable.

● Standard manufacturing
○ Optional

Material Equivalents

TANIM	DIN / EN		AISI / SAE / ASTM
Cast Iron	0.6025	EN-GJL-250 (GG25)	A48 Class 40B
Nodular Cast Iron	0.7040	EN-GJS-400-15 (GGG40)	A536 60-40-18
Nodular Cast Iron	0.7043	EN-GJS-400-18-LT (GGG40.3)	A536 60-40-18
Cast Steel	1.0619	GP240GHGS-C25	A216 WCB
Chrome Nickel Cast Steel	1.4308	GX5CrNi19-10	A351 CF8
Chrome Nickel Cast Steel (low carbon)	1.4309	GX2CrNi19-11	A351 CF3
Chrome Nickel Molybdenum Cast Steel	1.4408	GX5CrNiMo19-11-2	A351 CF8M
Chrome Nickel Molybdenum Cast Steel (low carbon)	1.4409	GX2CrNiMo19-11-2	A351 CF3M
Austenitic Cast Steel	1.4500	GX7NiCrMoCuNb25-20	A351 CN7M
Austenitic - Ferritic Cast Steel (duplex)	1.4517	GX2CrNiMoCuN25-6-3-3	A890 CD4MCuN
Austenitic - Ferritic Cast Steel (super duplex)	1.4469	GX2CrNiMoN26-7-4	A890 CE3MN
Martenzitic Stainless Cast Steel	1.4317	GX4CrNi13-4	A352 CA6NM
Martenzitic Stainless Cast Steel	1.4008	GX7CrNiMo12-1	A217 CA15
Cast Bronze (tin alloy)	2.1050.01	G-CuSn10	B427 C90700
Cast Bronze (nickel alloy)	2.0975.01	G-CuAl10Ni	B148 C95500
Cast Bronze (lead)	2.1096.01	G-CuSn5ZnPb	B584 C83600
Chrome Steel	1.4021	X20Cr13	A276 Type 420
Chrome Steel(heat treated)	1.4021	X20Cr13	A276 Type 420+QT
Chrome Nickel Steel	1.4301	X5CrNi18-10	A276 Type 304
Chrome Nickel Steel (low carbon)	1.4404	X2CrNiMo17-12-2	A276 Type 316L
Duplex (austenitic-ferritic) Steel	1.4460	X3CrNiMoN27-5-2	AISI 329
Duplex (austenitic-ferritic) Steel	1.4462	X2CrNiMoN22-5-3	UNS S32205

Flange Dimensions

DNe/DNb	Suction & Discharge (PN 16)			
	Df	k	s	n
40	150	110	19	4
50	165	125	19	4
65	185	145	19	4
80	200	160	19	8
100	220	180	19	8
125	250	210	19	8
150	285	240	23	8
200	340	295	23	12

EN 1092 - 2

" n " number of holes

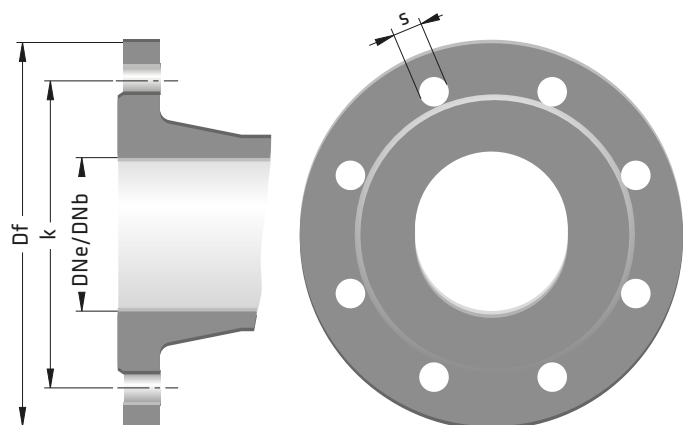



kalasanati.com
Training, Selecting, Purchasing

Standard

Pump • Fire Fighting Units • Booster Set

SKY

THERMAL OIL PUMPS



Handled Liquids

Heat transfer oil or low viscosity industrial oil without aggressive solid particles.

Technical Data

Discharge Flange _____ DN 32.....DN 125 mm

Capacity _____ up to 350 m³/h

Head _____ up to 105 m

Speed _____ up to 2900 rpm

Design Temperature _____ up to 320 °C

Cooling Method _____ With Air

Casing Pressure (Pmax) _____ 10 bar (16 bar)

(Pmax: Suction Pressure + Shut off Head)

Desing Features

- Horizontal, radially split volute casing type, single stage, end suction, air cooled centrifugal pumps with closed impeller.

- Suction and discharge flanges conform to EN 1092-2 / PN 16.

- Due to the back-pull-out design, the complete bearing assembly including impeller and casing cover can be dismantled without removing the volute casing from the pipe system. (With spacer coupling application, also possible to take out the rotor group without dismantling the electric motor.)

- All impellers are balanced dynamically according to ISO 1940 class 6.3.

- Axial thrust is balanced by impeller back ribs.

- Direction of rotation is clockwise viewed from drive end.

- Bearings of SKY type pumps are “life time grease lubricated” ball bearings.

Shaft Sealing

- High temperature resistant mechanical seals are used.

Pressure & Temperature Limits

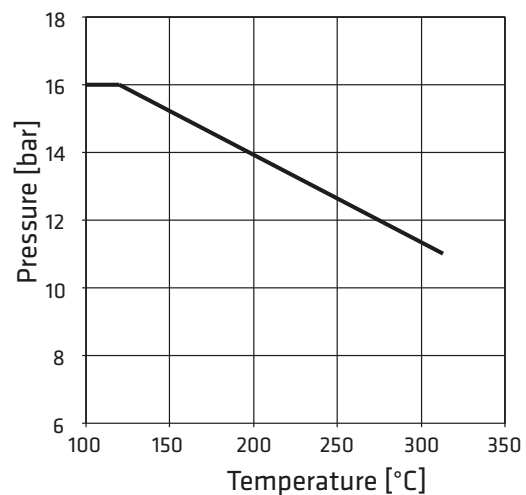

Pump Designation

Pump Type _____

Discharge Nozzle (DN-mm) _____

Nominal Impeller Diameter (mm) _____

SKY **100 - 250**

Field Chart



Kalasanati.com

SKY

1450 rpm

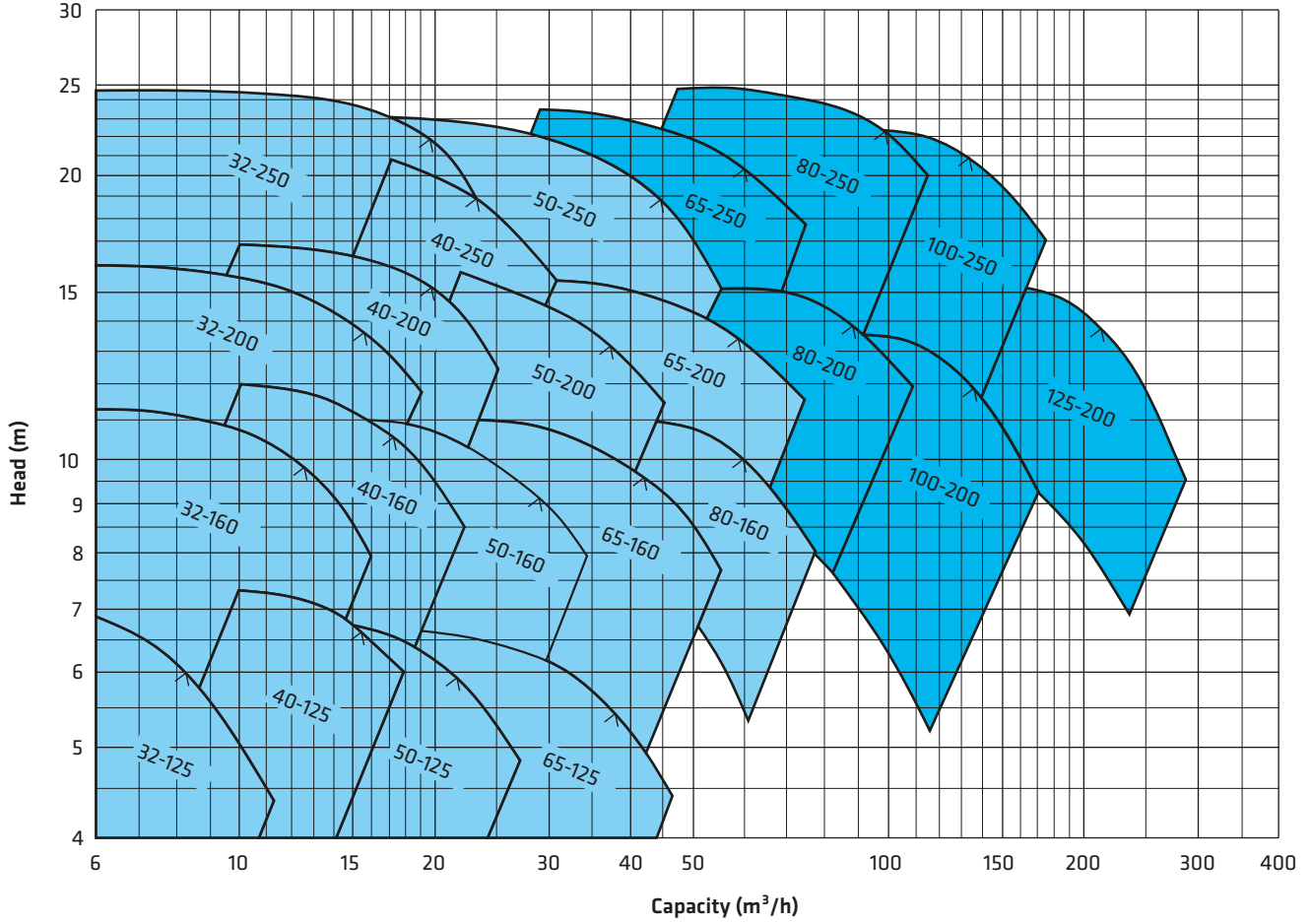

2900 rpm

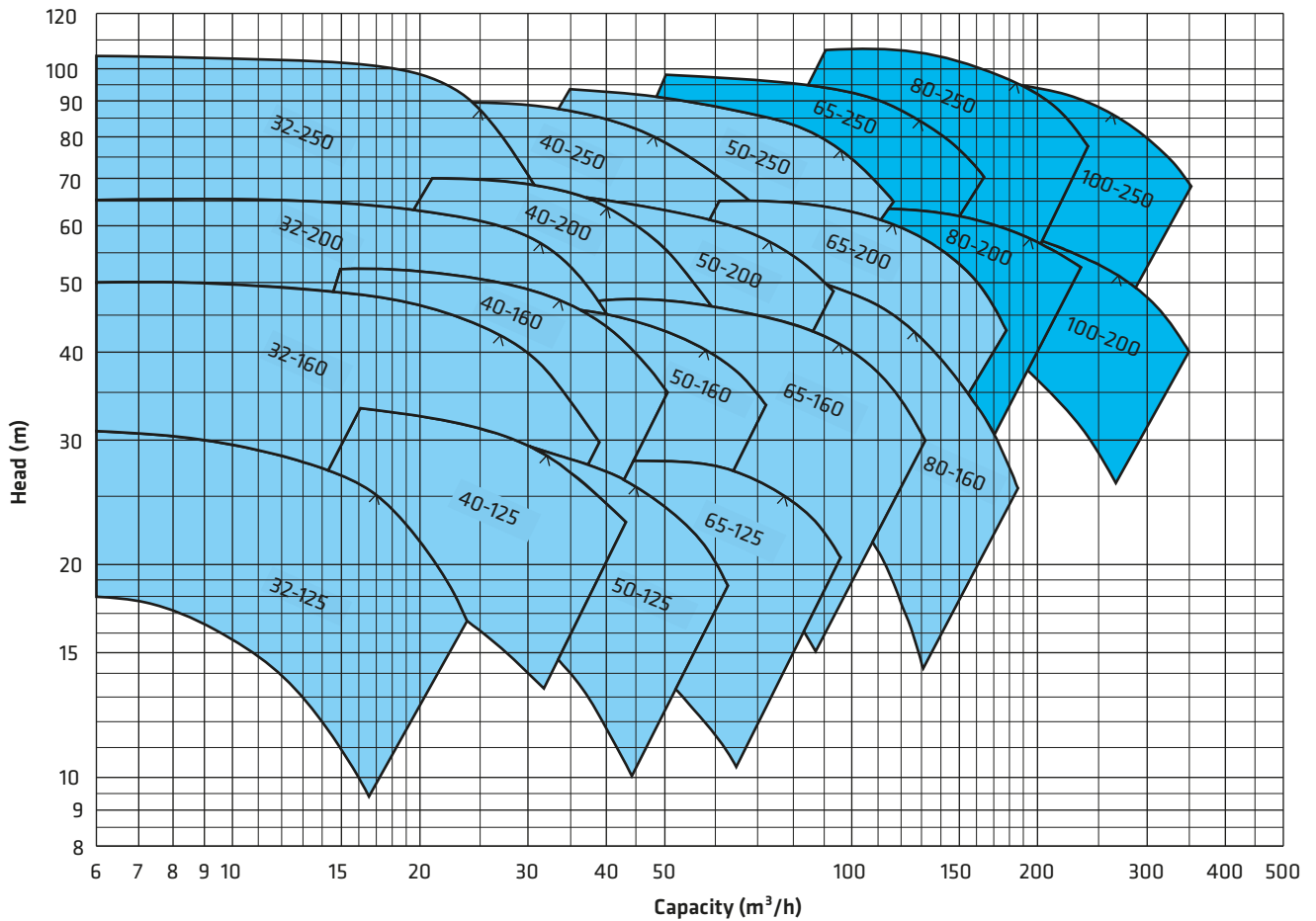

Sectional Drawings

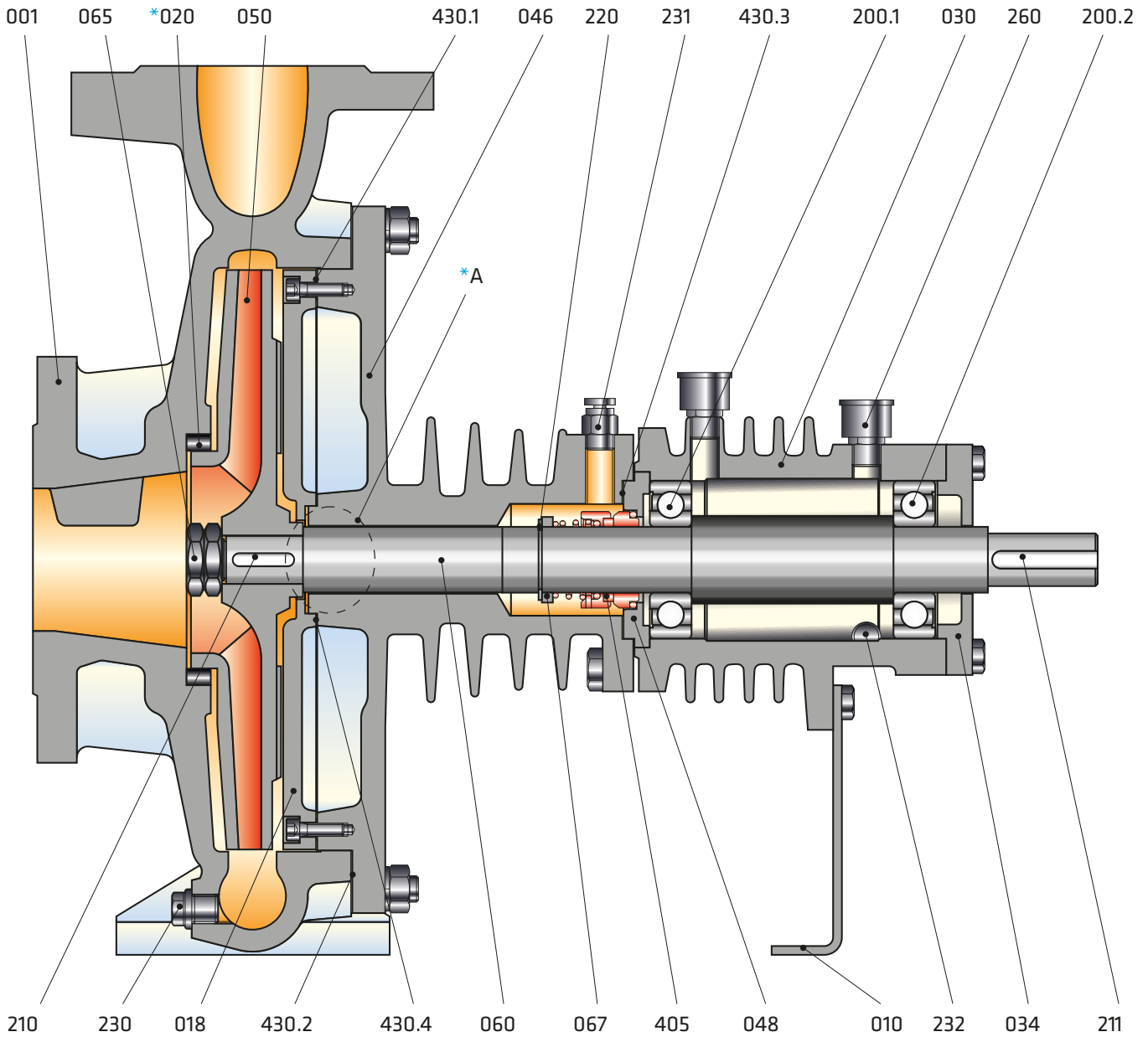

Part List

001	Volute Casing	210	Impeller Key
010	Support Foot	211	Coupling Key
018	Wear Plate	220	Circlip
*020	Wear Ring	230	Draing Plug
030	Bearing Housing	231	Air Venting Plug
034	Bearing Cover	232	Grease Drain Plug
046	Casing Cover	260	Grease Nipple
048	Mechanical Seal Cover	*400	Soft Packing (type 6050)
050	Impeller	405	Mechanical Seal
060	Shaft	430.1	Gasket (wear plate)
065	Impeller Nut	430.2	Gasket (casing)
067	Spacer Sleeve (mechanical seal)	430.3	Gasket (mech. seal cover)
*070	Spacer Sleeve (soft packing)	430.4	Gasket (wear plate)
200	Ball Bearing		

*A

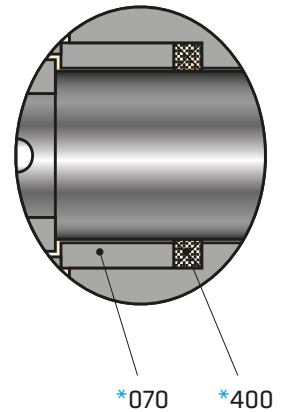

* Optional

Technical Data

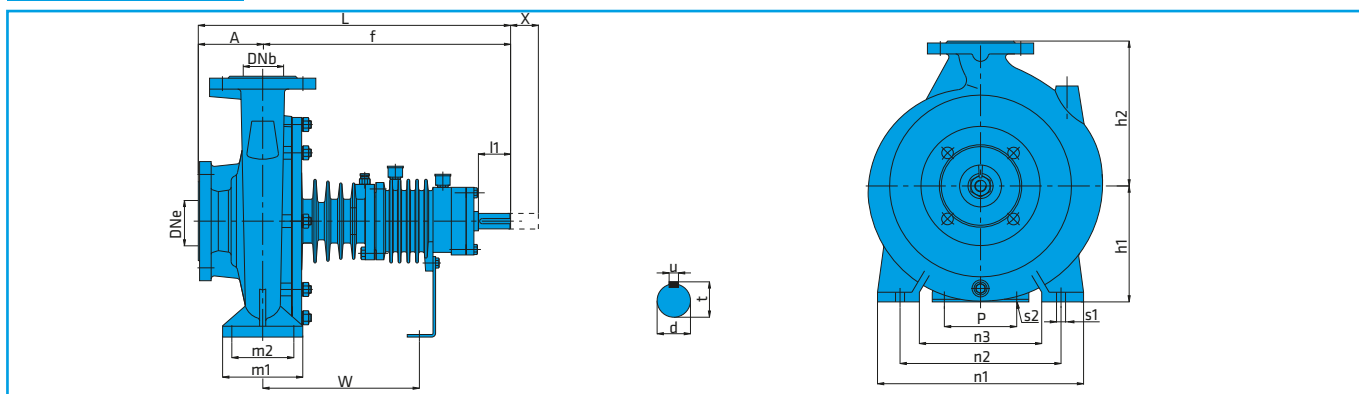

Pump Type	Overall Dimensions (mm)							Support & Foot Dimensions(mm)								Shaft (mm)				Spacer (mm) x*	
	DNe	DNb	A	f	L	h1	h2	m1	m2	n1	n2	n3	s1	p	s2	w	d	l1	t		u
32-125	50	32	80	385	465	112	140	100	70	190	140	90	14	110	14	240	24	50	27	8	100
40-125	65	40	80	385	465	112	140	100	70	210	160	90	14	110	14	240	24	50	27	8	100
50-125	65	50	100	385	485	132	160	100	70	240	190	145	14	110	14	240	24	50	27	8	100
65-125	80	65	100	385	485	160	180	125	95	280	212	150	14	110	14	240	24	50	27	8	100
32-160	50	32	80	385	465	132	160	100	70	240	190	145	14	110	14	240	24	50	27	8	100
40-160	65	40	80	385	465	132	160	100	70	240	190	145	14	110	14	240	24	50	27	8	100
50-160	65	50	100	385	485	160	180	100	70	265	212	145	14	110	14	240	24	50	27	8	100
65-160	80	65	100	385	485	160	200	125	95	280	212	150	14	110	14	240	24	50	27	8	100
80-160	100	80	125	395	520	180	225	125	95	320	250	190	14	110	14	250	24	50	27	8	140
32-200	50	32	80	385	465	160	180	100	70	240	190	140	14	110	14	240	24	50	27	8	100
40-200	65	40	100	385	485	160	180	100	70	265	212	166	14	110	14	240	24	50	27	8	100
50-200	65	50	100	385	485	160	200	100	70	265	212	166	14	110	14	240	24	50	27	8	100
65-200	80	65	100	385	485	180	225	125	95	320	250	190	14	110	14	240	24	50	27	8	140
80-200	100	80	125	500	625	180	250	125	95	345	280	215	18	110	14	310	32	80	35	10	140
100-200	125	100	125	505	630	200	280	160	120	360	280	200	18	110	14	310	32	80	35	10	140
125-200	150	125	140	505	645	250	315	165	120	400	315	230	18	110	14	310	32	80	35	10	140
32-250	50	32	100	385	485	180	225	125	95	320	250	190	14	110	14	240	24	50	27	8	100
40-250	65	40	100	385	485	180	225	125	95	320	250	190	14	110	14	240	24	50	27	8	100
50-250	65	50	100	385	485	180	225	125	95	320	250	190	14	110	14	240	24	50	27	8	100
65-250	80	65	100	495	595	200	250	160	120	360	280	200	18	110	14	305	32	80	35	10	140
80-250	100	80	125	495	620	200	280	160	120	400	315	240	18	110	14	305	32	80	35	10	140
100-250	125	100	140	500	640	225	280	160	110	400	315	240	18	110	14	310	32	80	35	10	140

* Gap necessary for the withdrawal of the pump rotor from the driven end without the need for disconnecting the motor and pipework (spacer coupling application)

Material Options

Part List	0.6025	0.7040	1.4408	1.4021	1.4401
	Cast Iron		●	○	
Nodular Cast Iron		●	○		
Chrome Nickel Moly. Cast Steel		●	○		
Chrome Steel		●	○		
Chrome Nickel Moly. Steel				●	○
Bearing Housing	●	○	○		
Wear Ring	○	○	○		
Wear Plate		●	○		
Mechanical Seal	EN 12756				

Material Equivalents

Description	DIN / EN		AISI / SAE / ASTM
	Cast Iron	0.6025	EN-GJL-250 (GG25)
Nodular Cast Iron	0.7040	EN-GJS-400-15 (GGG40)	A 536 Gr. 60-40-18
Chrome Nickel Moly. Cast Steel	1.4408	GX5CrNiMo19-11-2	A351 CF8M
Chrome Steel	1.4021	X20Cr13	A276 Type 420
Chrome Nickel Moly. Steel	1.4301	X5CrNi18-10	A276 Type 304

● Standard manufacturing
○ Optional

Flange Dimensions

EN 1092 - 2	DNe/DNb	Suction & Discharge (PN 16)			
		Df	k	s	n
	32	140	100	19	4
	40	150	110	19	4
	50	165	125	19	4
	65	185	145	19	4
	80	200	160	19	8
	100	220	180	19	8
	125	250	210	19	8
	150	285	240	23	8

" n " number of holes

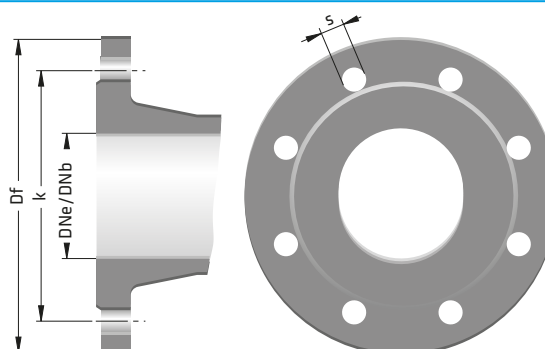

SCP

ISO 2858

NORM PUMPS



Handled Liquids

Clean or normal contaminated low or medium viscosity liquids without solid & fibrous particles.

Technical Data

Discharge Flange _____ DN 32.....DN 250 mm

Capacity _____ up to 1500 m³/h

Head _____ up to 160 m

Speed _____ up to 2900 rpm

Operating Temperature _____ -10 °C' to +175 °C*

Casing Pressure (Pmax) _____ 16 bar (25 bar)*

(Pmax: Suction Pressure + Shut off Head)

(*) The Material of pumps differ according to the type of pumped liquid, operating temperature and pressure. Contact for detailed information.

Design Features

- Horizontal, radially split volute casing type, single stage, end suction centrifugal pumps with closed or semi-open impeller.

- In addition to 28 basic sizes conforming with ISO 2858, there are 10 additional sizes. Dimensions of additional sizes may differ from other suppliers.

- Heavy duty shaft not in contact with the medium handled (dry shaft)

- For casing sealing, confined gaskets are used to prevent blow-out under pressure.

- Suction and discharge flanges conform to EN 1092-2 / PN 16. (EN 1092-1 / PN 16 for steel or stainless steel casing)

- Due to the back-pull-out design, the complete bearing assembly including impeller and casing cover can be dismantled without removing the volute casing from the pipe system. (With spacer coupling application, also possible to take out the rotor group without dismantling the electric motor.)

- All impellers are balanced dynamically or statically according to ISO 1940 class 6.3.

- For closed impellers, axial thrust is balanced by impeller balancing holes system while for semi-open impellers, it is balanced by back ribs.

- Direction of rotation is clockwise viewed from drive end.

- Bearings of SCP type pumps are always oil lubricated.

Shaft Sealing

- Depending on request or requirement, pumps with soft packing or single, double and cartridge type mechanical seals can be supplied.

- External seal cooling system may be used if required.

Pump Designation

Pump Type _____

Discharge Nozzle (DN-mm) _____

Nominal Impeller Diameter(mm) _____

Impeller Type (A: semi-open) _____

SCP 125 - 315 - A



1450 rpm

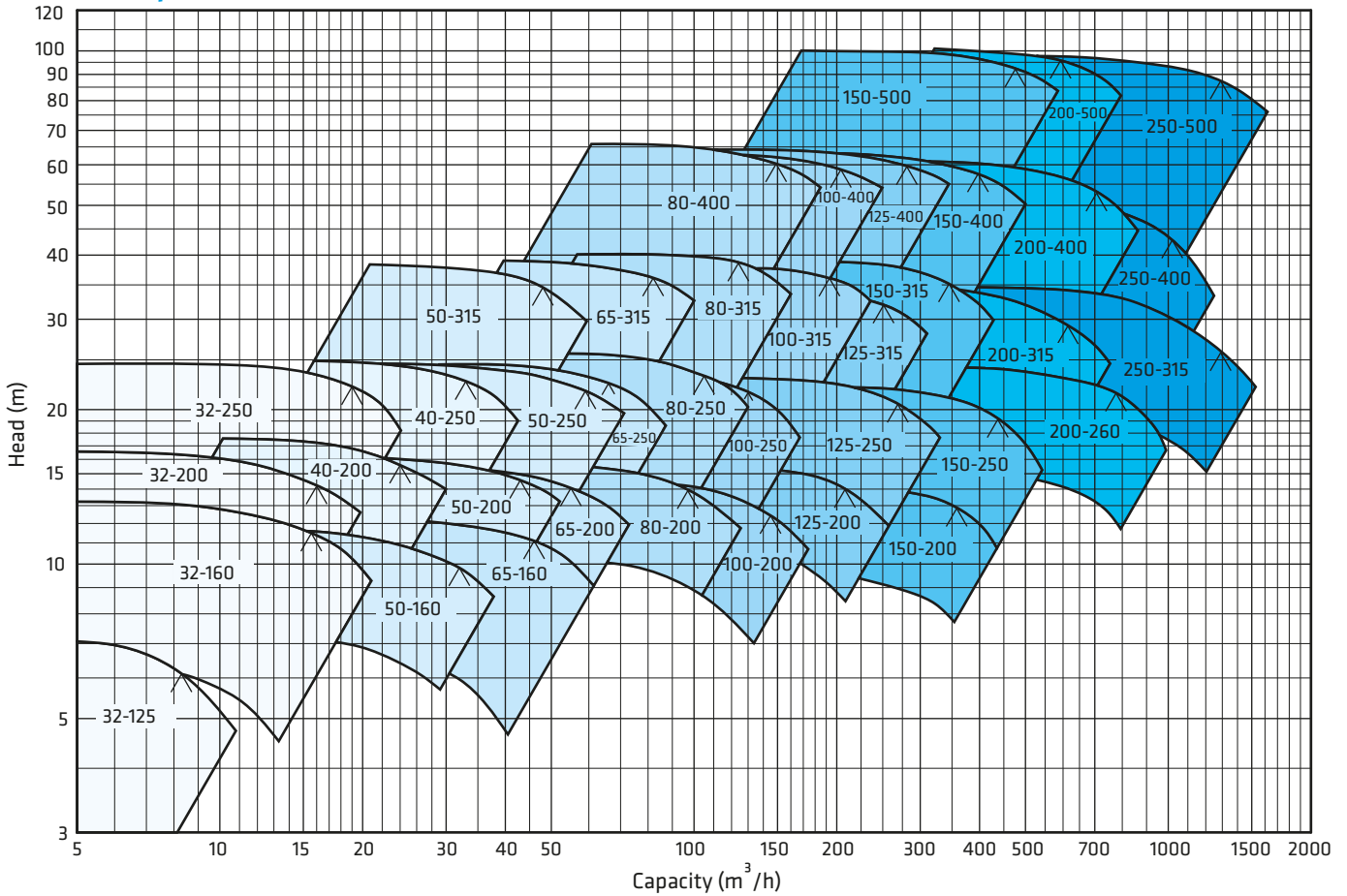

2900 rpm

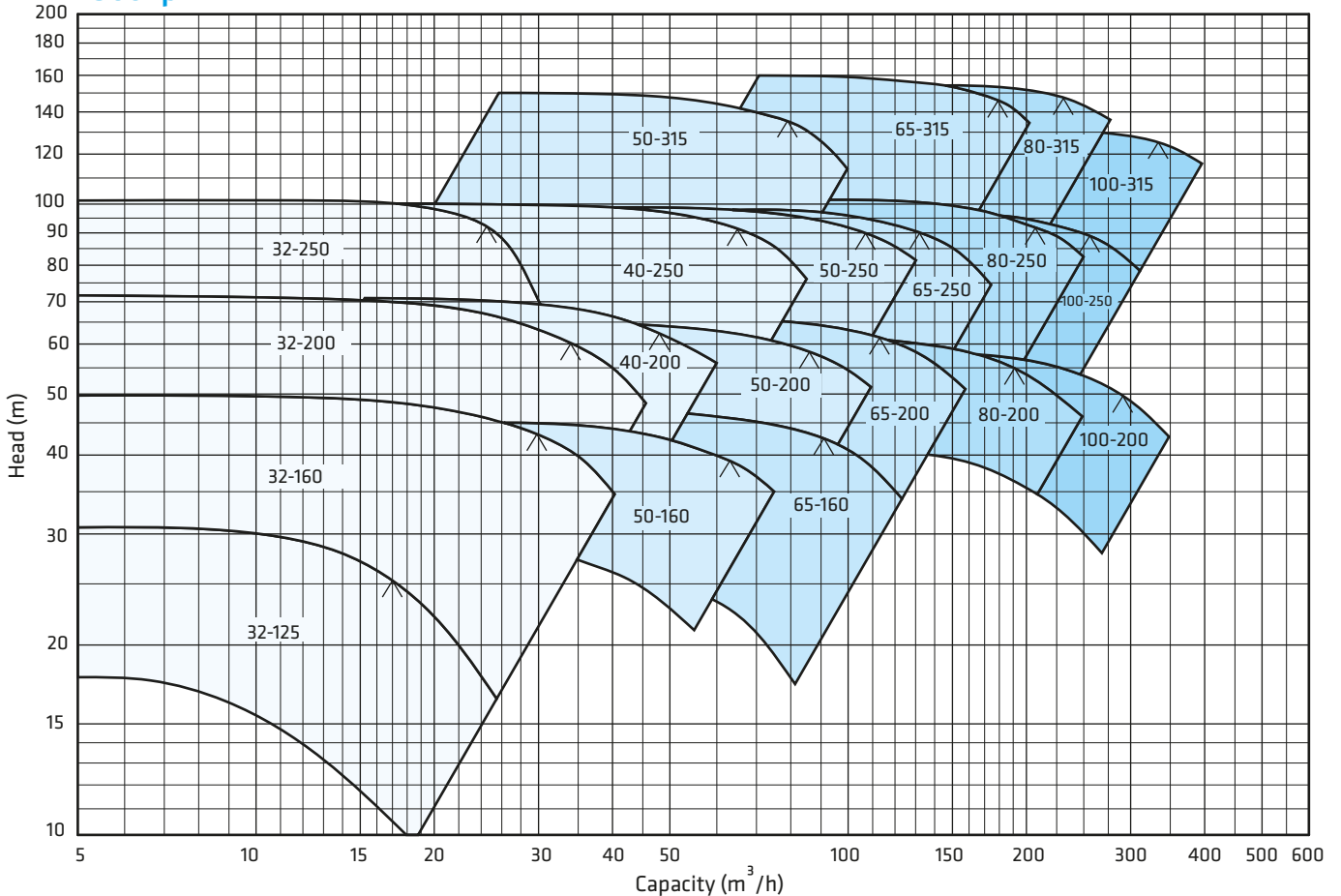

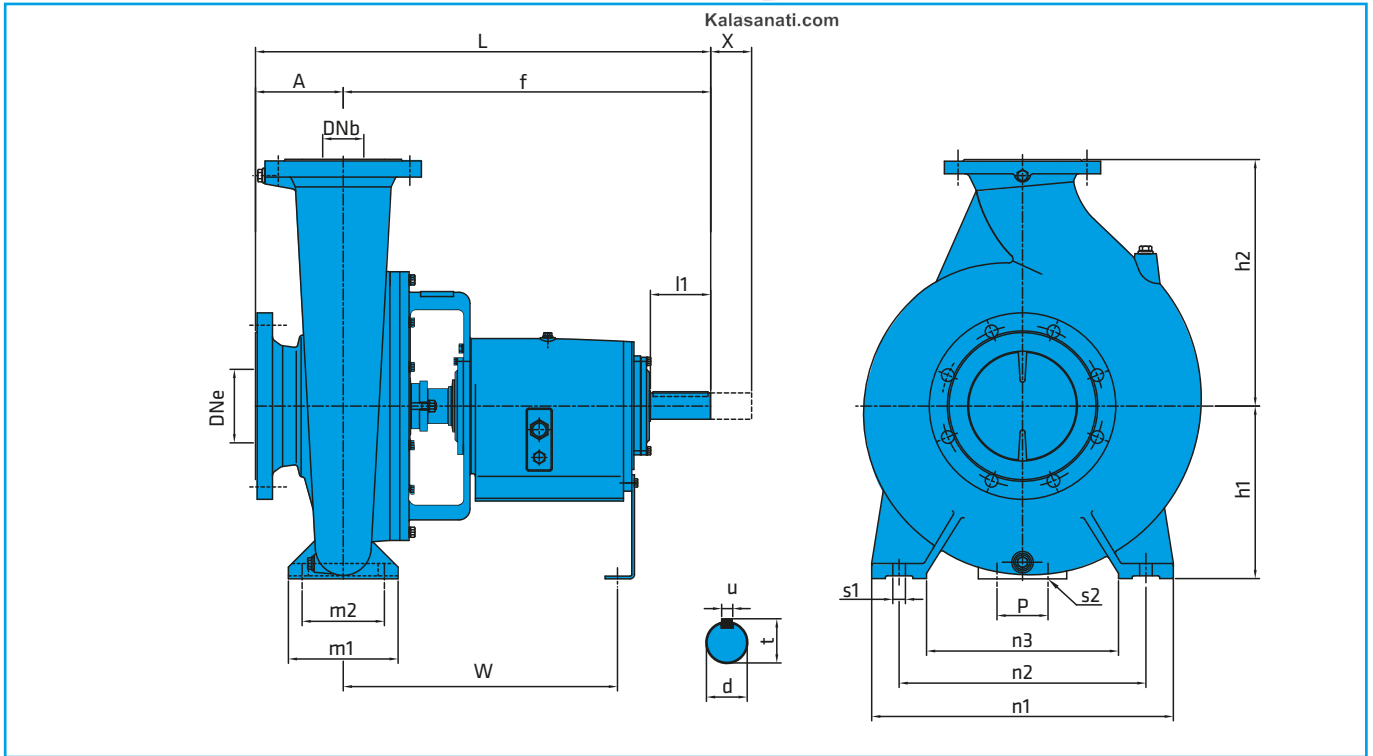

PUMP TYPE		Dimensions (mm)																				
ISO 2858	Additional	Overall Dimensions						Support and Foot Dimensions							Shaft End				Spacer			
		DNe	DNb	A	f	L	h1	h2	m1	m2	n1	n2	n3	s1	p	s2	w	d	l1	t	u	x
32-125		50	32	80	385	465	112	140	100	70	190	140	90	14	110	14	285	24	50	27	8	100
32-160		50	32	80	385	465	132	160	100	70	240	190	140	14	110	14	285	24	50	27	8	100
32-200		50	32	80	385	465	160	180	100	70	240	190	140	14	110	14	285	24	50	27	8	100
32-250		50	32	80	385	465	180	225	125	95	320	250	190	14	110	14	370	32	80	35	10	100
40-200		65	40	100	385	485	160	180	100	70	265	212	165	14	110	14	285	24	50	27	8	100
40-250		65	40	100	500	600	180	225	125	95	320	250	190	14	110	14	370	32	80	35	10	100
50-160		80	50	100	385	485	160	180	100	70	265	212	165	14	110	14	285	24	50	27	8	100
50-200		80	50	100	385	485	160	200	100	70	265	212	165	14	110	14	285	24	50	27	8	100
50-250		80	50	125	500	625	180	225	125	95	320	250	190	14	110	14	370	32	80	35	10	100
50-315		80	50	125	500	625	225	280	125	95	345	280	215	14	110	14	370	32	80	35	10	100
65-160		100	65	100	500	600	160	200	125	95	280	212	150	14	110	14	370	32	80	35	10	140
65-200		100	65	100	500	600	180	225	125	95	320	250	190	14	110	14	370	32	80	35	10	140
65-250		100	65	125	500	625	200	250	160	120	360	280	200	19	110	14	370	32	80	35	10	140
65-315		100	65	125	530	655	225	280	160	120	400	315	240	19	110	14	370	42	110	45	12	140
80-200		125	80	125	500	625	180	250	125	95	345	280	215	14	110	14	370	32	80	35	10	140
80-250		125	80	125	500	625	225	280	160	120	400	315	240	19	110	14	370	32	80	35	10	140
80-315		125	80	125	530	655	250	315	160	120	400	315	240	19	110	14	370	42	110	45	12	140
80-400		125	80	125	530	655	280	355	160	120	435	355	275	19	110	14	370	42	110	45	12	140
100-200		125	100	125	500	625	200	280	160	120	360	280	200	19	110	14	370	32	80	35	10	140
100-250		125	100	140	530	670	225	280	160	120	400	315	240	19	110	14	370	42	110	45	12	140
100-315		125	100	140	530	670	250	315	160	120	400	315	240	19	110	14	370	42	110	45	12	140
100-400		125	100	140	530	670	280	355	200	150	500	400	300	23	110	14	370	42	110	45	12	140
	125-200	150	125	140	500	640	250	315	160	120	400	315	240	19	110	14	370	32	80	35	10	140
125-250		150	125	140	530	670	250	355	160	120	400	315	240	19	110	14	370	42	110	45	12	140
125-315		150	125	140	530	670	280	355	200	150	500	400	300	23	110	14	370	42	110	45	12	140
125-400		150	125	140	530	670	315	400	200	150	500	400	300	23	110	14	370	42	110	45	12	140
	150-200	200	150	160	545	705	280	355	200	150	550	450	350	23	140	14	381	42	110	45	10	180
150-250		200	150	160	530	690	280	375	200	150	550	450	350	23	140	14	366	42	110	45	12	180
150-315		200	150	160	670	830	315	400	200	150	550	450	350	23	140	19	500	48	110	51,5	14	180
150-400		200	150	160	670	830	315	450	200	150	550	450	350	23	140	19	500	48	110	51,5	14	180
	150-500	200	150	200	730	930	400	525	250	200	720	600	435	27	140	19	495	55	110	59	16	140
	200-260	250	200	200	630	830	355	450	250	200	600	500	360	23	140	20	410	48	110	51,55	14	160
	200-315	250	200	200	684	884	355	450	250	200	600	500	360	23	140	20	520	48	110	45	14	160
	200-400	250	200	180	725	905	400	500	250	200	600	500	360	23	140	20	490	55	110	59	16	160
	200-500	250	200	210	925	1135	400	525	300	240	720	600	435	27	140	20	640	70	140	74,5	20	160
	250-315	300	250	230	730	960	400	525	300	240	720	600	435	27	140	20	515	55	110	59	16	200
	250-400	300	250	230	750	980	400	525	300	240	720	600	435	27	140	20	515	55	110	59	16	200
	250-500	300	250	225	940	1165	450	630	300	240	720	600	435	27	140	20	670	70	140	74,5	20	200

Note: All rights reserved due to dimension change.

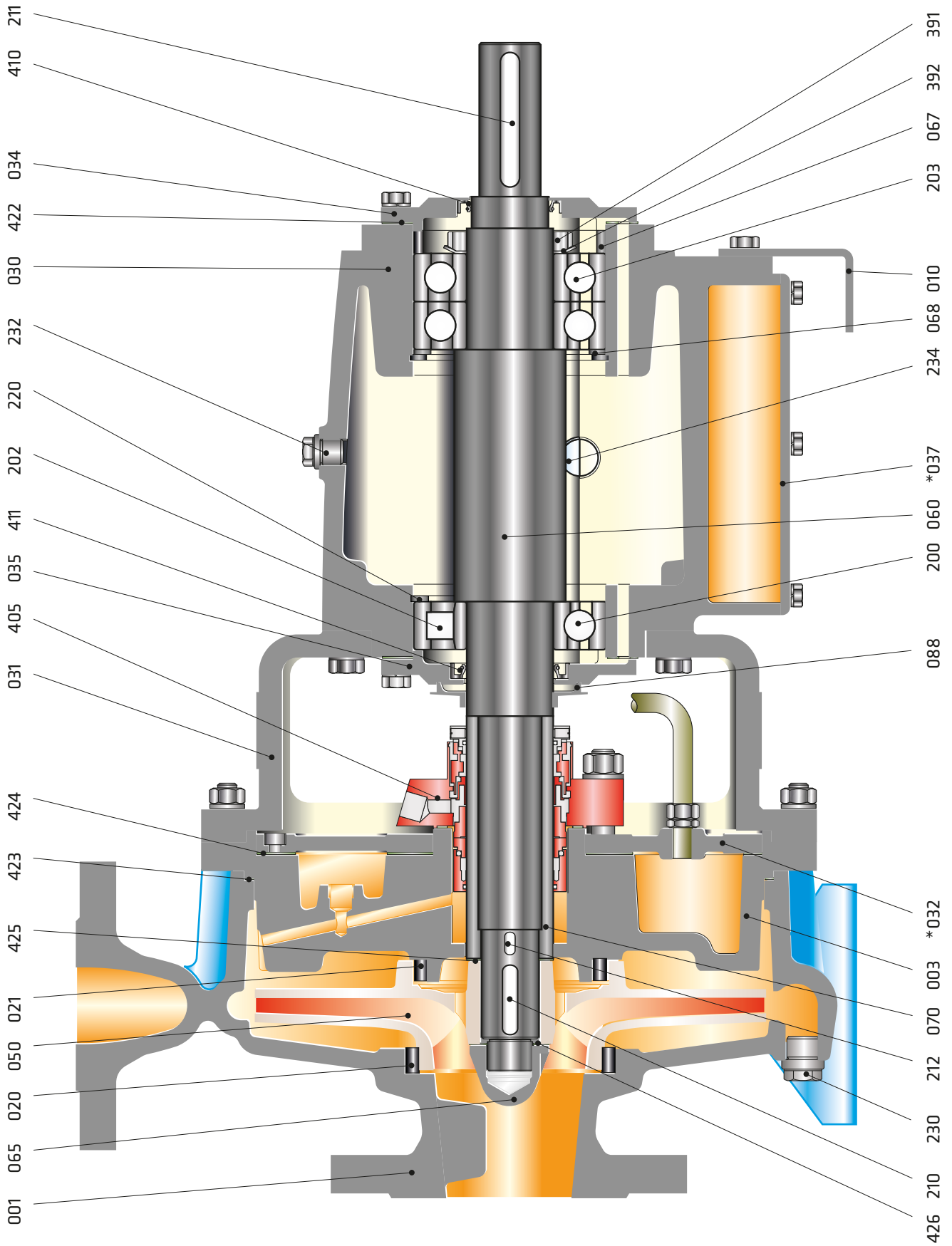

Soft Packing Application

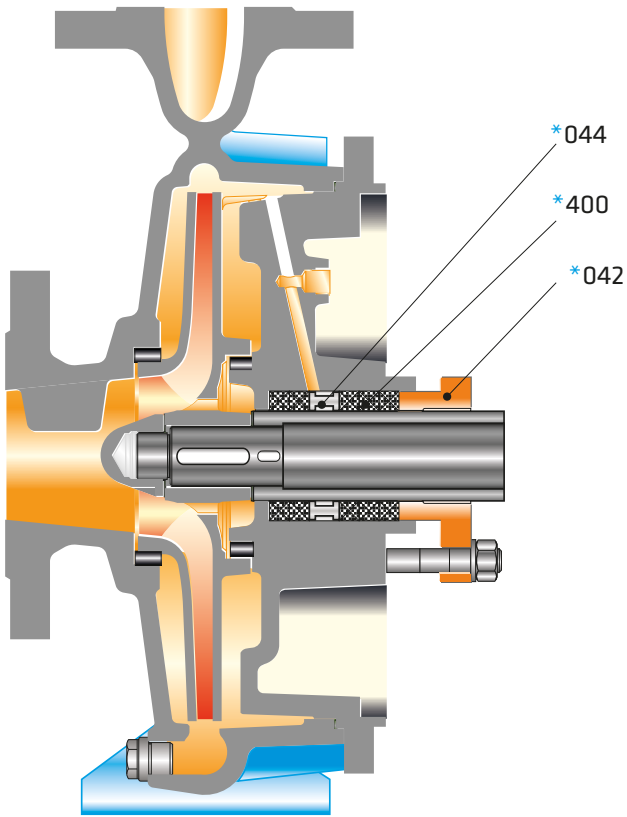

Semi-open Impeller Application

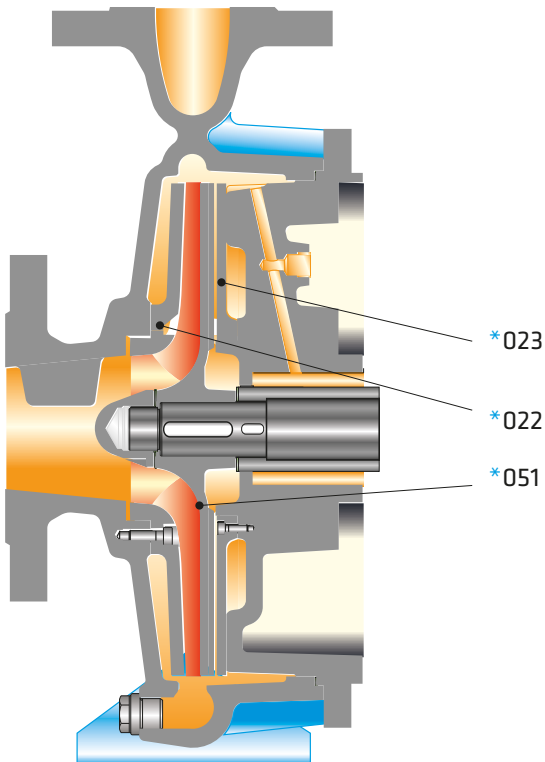

Part List

001	Volute Casing
003	Casing Cover
010	Support Foot
020	Wear Ring (casing)
021	Wear Ring (casing cover)
*022	Front Wear Plate
*023	Back Wear Plate
030	Bearing Bracket
031	Bearing Bracket Lantern
*032	Cooling-Heating Jacket Cover
034	Bearing Cover (outboard)
035	Bearing Cover (inboard)
*037	Bearing Cooling Cover
*042	Gland
*044	Lantern Ring
050	Impeller
*051	Semi-open impeller
060	Shaft
065	Impeller Nut
067	Bearing Spacer Sleeve
068	Bearing Spacer Sleeve
070	Shaft Protecting Sleeve
088	Thrower
200	Ball Bearing
202	Cylindrical Roller Bearing
203	Angular Contact Ball Bearing
210	Key (impeller)
211	Key (coupling)
212	Shaft Sleeve Key
220	Circlip
230	Drain Plug
232	Oil Filling Plug
234	Oil Sight Gauge
391	Shaft Nut
392	Lock Washer
*400	Soft Packing
405	Mechanical Seal
410	Lip Seal
411	Lip Seal
422	Gasket
423	Gasket
424	Gasket
425	Gasket
426	Gasket

* Optional



Kalasanati.com

SCP

Technical Data

PART LIST	10	30	35	20	60	6L	70	7L	8M	7D	7S	8N	80	4C	4A	40	80	8T	60	7L	7E	7D	
	0.6025	0.7040	0.7043	1.0619	1.4308	1.4309	1.4408	1.4409	1.4500	1.4517	1.4469	1.4317	1.4008	2.1050.01	2.0975.01	2.1096.01	1.4021	1.4021+QT	1.4301	1.4404	1.4460	1.4462	
Volute Casing	●	○	○	○	○	○	○	○	○	○	○	○	○	○	○	○	○	○	○	○	○	○	○
Casing Cover	●	○	○	○	○	○	○	○	○	○	○	○	○	○	○	○	○	○	○	○	○	○	○
Impeller	●	○	○	○	○	○	○	○	○	○	○	○	○	○	○	○	○	○	○	○	○	○	○
Shaft																	●	○	○	○			○
Bearing Bracket	●	○	○	○	○	○	○	○															
Wear Ring	●	○	○	○	○	○	○	○	○	○	○	○	○	○	○	○	○	○	○	○	○	○	○
Shaft Protecting Sleeve																	●	○	○	○			○
Mechanical Seal (*)	EN 12756																						

(*) Optional :Depending on customer requirement or request different types and brands of mechanical seals are applicable.

● Standard manufacturing
○ Optional

Material Equivalents

Description	DIN / EN		AISI / SAE / ASTM
Cast Iron	0.6025	EN-GJL-250 (GG25)	A48 Class 40B
Nodular Cast Iron	0.7040	EN-GJS-400-15 (GGG40)	A536 60-40-18
Nodular Cast Iron	0.7043	EN-GJS-400-18-LT (GGG40.3)	A536 60-40-18
Cast Steel	1.0619	GP240GHGS-C25	A216 WCB
Chrome Nickel Cast Steel	1.4308	GX5CrNi19-10	A351 CF8
Chrome Nickel Cast Steel (low carbon)	1.4309	GX2CrNi19-11	A351 CF3
Chrome Nickel Molybdenum Cast Steel	1.4408	GX5CrNiMo19-11-2	A351 CF8M
Chrome Nickel Molybdenum Cast Steel (low carbon)	1.4409	GX2CrNiMo19-11-2	A351 CF3M
Austenitic Cast Steel	1.4500	GX7NiCrMoCuNb25-20	A351 CN7M
Austenitic - Ferritic Cast Steel (duplex)	1.4517	GX2CrNiMoCuN25-6-3-3	A890 CD4MCuN
Austenitic - Ferritic Cast Steel (super duplex)	1.4469	GX2CrNiMoN26-7-4	A890 CE3MN
Martenzitic Stainless Cast Steel	1.4317	GX4CrNi13-4	A352 CA6NM
Martenzitic Stainless Cast Steel	1.4008	GX7CrNiMo12-1	A217 CA15
Cast Bronze (tin alloy)	2.1050.01	G-CuSn10	B427 C90700
Cast Bronze (nickel alloy)	2.0975.01	G-CuAl10Ni	B148 C95500
Cast Bronze (lead)	2.1096.01	G-CuSn5ZnPb	B584 C83600
Chrome Steel	1.4021	X20Cr13	A276 Type 420
Chrome Steel(heat treated)	1.4021	X20Cr13	A276 Type 420+QT
Chrome Nickel Steel	1.4301	X5CrNi18-10	A276 Type 304
Chrome Nickel Steel (low carbon)	1.4404	X2CrNiMo17-12-2	A276 Type 316L
Duplex (austenitic-ferritic) Steel	1.4460	X3CrNiMoN27-5-2	AISI 329
Duplex (austenitic-ferritic) Steel	1.4462	X2CrNiMoN22-5-3	UNS S32205

Flange Dimensions

DNe/DNb	Suction & Discharge (PN 16)			
	Df	k	s	n
32	140	100	19	4
40	150	110	19	4
50	165	125	19	4
65	185	145	19	4
80	200	160	19	8
100	220	180	19	8
125	250	210	19	8
150	285	240	23	8
200	340	295	23	12
250	405	355	28	12
300	460	410	28	12

" n " number of holes

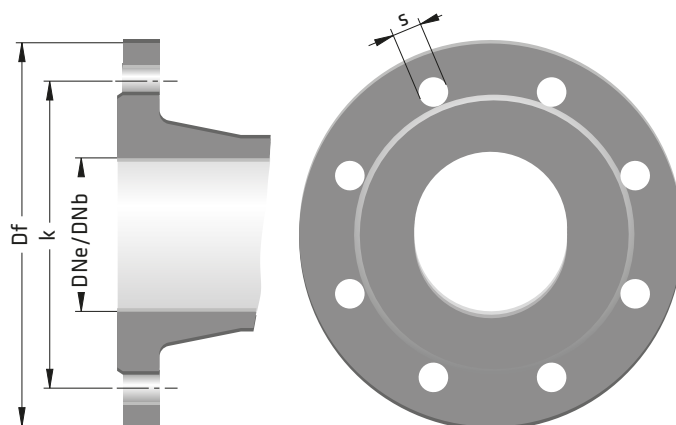



Pump • Fire Fighting Units • Booster Set

SCP-HT

HOT WATER PUMPS



Kalasanati.com



Handled Liquids

SCP-HT pumps are specially designed for hot water and geothermal water application.

Technical Data

Discharge Flange _____ DN 32.....DN 250 mm

Capacity _____ up to 1500 m³/h

Head _____ up to 160 m

Speed _____ up to 2900 rpm

Design Temperature _____ up to +230 °C*

Casing Pressure (Pmax) _____ 25 bar (40 bar)*

(Pmax: Suction Pressure + Shut off Head)

(*) The Material of pumps differ according to the type of pumped liquid, operating temperature and pressure. Contact for detailed information.

Design Features

- Horizontal, radially split volute casing type, single stage, end suction centrifugal pumps with closed impeller.
- Heavy duty shaft not in contact with the medium handled (dry shaft)
- For casing sealing, confined gaskets are used to prevent blow-out under pressure.
- Coupling misalignment due to thermal expansions are mainly reduced with centerline mounting design.
- Suction and discharge flanges conform to EN 1092-2 / PN 25. (EN 1092-1 / PN 25 for steel or stainless steel casing)

Pump Designation

Pump Type _____

Discharge Nozzle (DN-mm) _____

Nominal Impeller Diameter (mm) _____

- Due to the back-pull-out design, the complete bearing assembly including impeller and casing cover can be dismantled without removing the volute casing from the pipe system. (With spacer coupling application, also possible to take out the rotor group without dismantling the electric motor.)
- All impellers are balanced dynamically or statically according to ISO 1940 class 6.3.
- Axial thrust is balanced by impeller balancing holes system.
- Direction of rotation is clockwise viewed from drive end.
- Bearings of SCP-HT type pumps are always oil lubricated.

Shaft Sealing

- Depending on request or requirement, pumps with soft packing or single, double and cartridge type mechanical seals can be supplied.
- External seal cooling system may be used if required.

Pressure & Temperature Limits

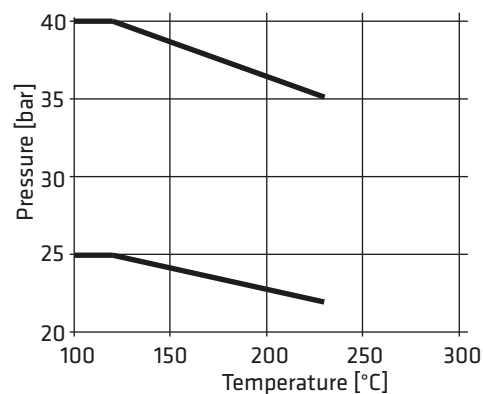

SCP-HT 100 - 250



Kalasanati.com

1450 rpm

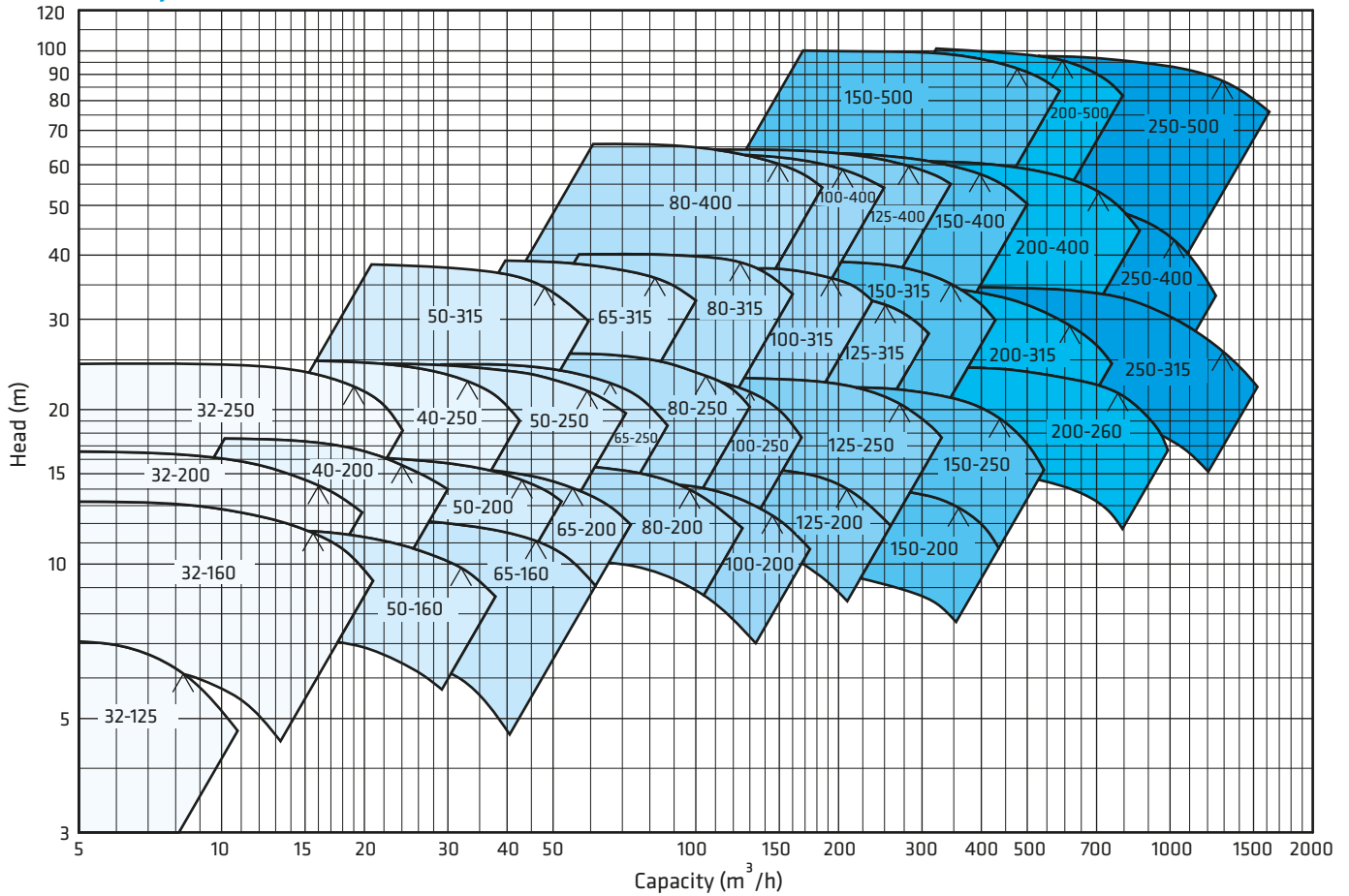

2900 rpm

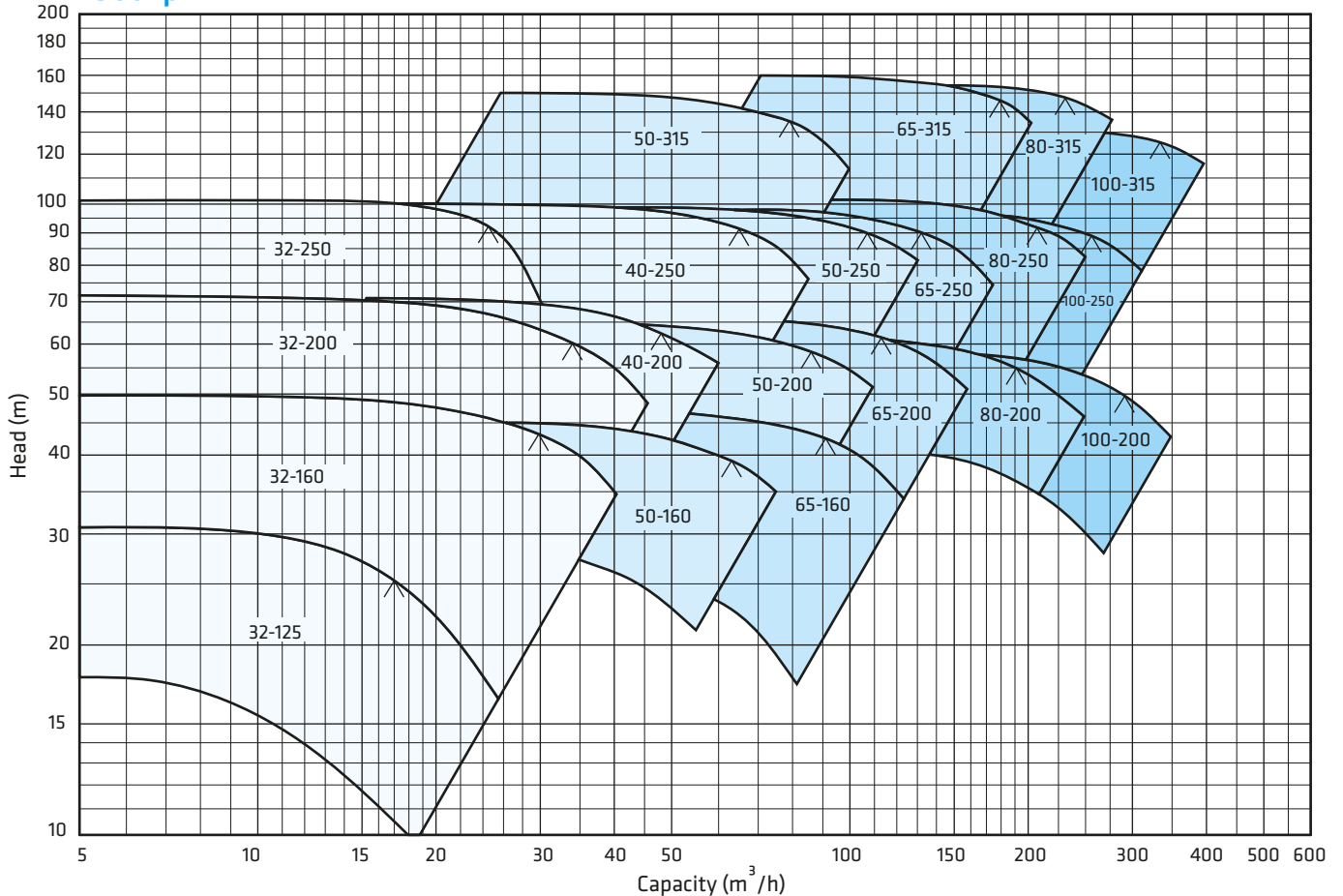



Kalasanati.com

SCP-HT

Sectional Drawings

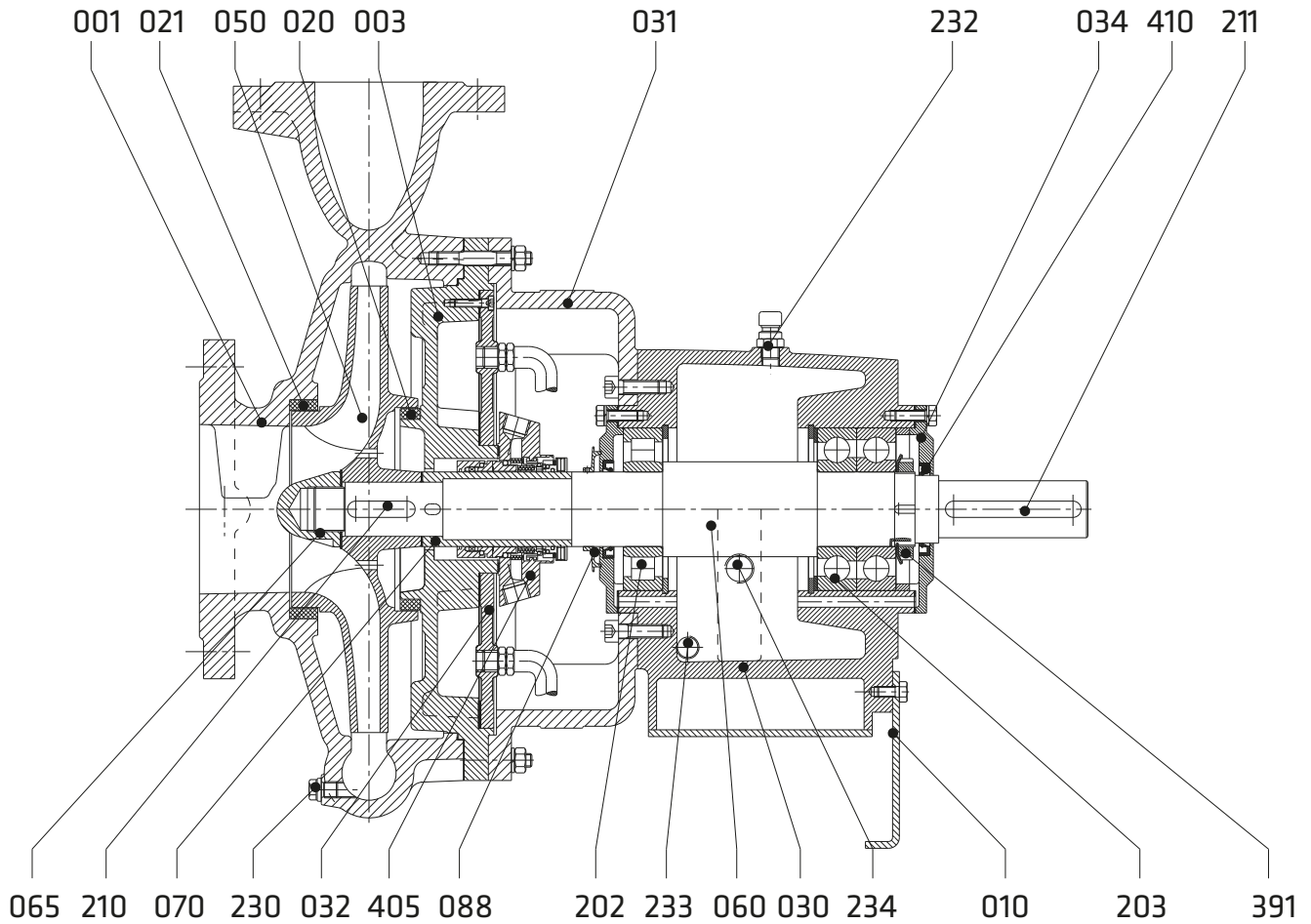

Part List

001	Volute Casing
003	Casing Cover
010	Support Foot
020	Wear Ring (casing)
021	Wear Ring (casing cover)
030	Bearing Bracket
031	Bearing Bracket Lantern
032	Cooling - Heating jacket Cover
034	Bearing Cover
042	Gland
044	Lantern Ring
050	Impeller
060	Shaft
065	Impeller Nut
070	Shaft Protecting Sleeve
088	Thrower
202	Cylindrical Roller Bearing
203	Angular Contact Ball Bearing
210	Impeller Key
211	Key (coupling)
212	Shaft Sleeve Key
230	Drain Plug
232	Oil Filling Plug
233	Oil Drain Plug
234	Oil Sight Gauge
391	Shaft Nut
400*	Soft Packing Seal
405	Mechanical Seal
410	Lip Seal

* Optional

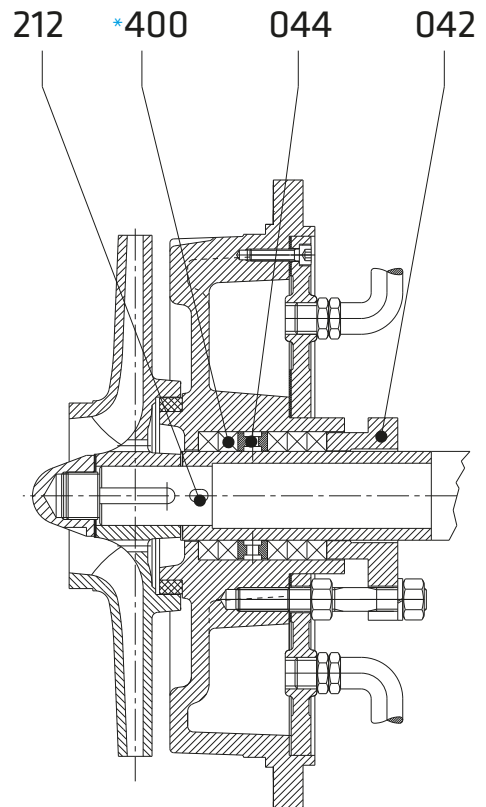



Part List	10	30	20	60	6L	70	7L	8M	7D	7S	8N	80	80	8T	60	7L	7E	7D	
	0.6025	0.7040	1.0619	1.4308	1.4309	1.4408	1.4409	1.4500	1.4517	1.4469	1.4317	1.4008	1.4021	1.4021+QT	1.4301	1.4404	1.4460	1.4462	
Volute Casing		●	○	○	○	○	○	○	○	○	○	○							
Casing Cover		●	○	○	○	○	○	○	○	○	○	○							
Impeller	●	○	○	○	○	○	○	○	○	○	○	○						○	
Shaft													●	○	○	○			○
Bearing Bracket	●	○	○	○	○	○	○												
Wear Ring	●	○	○	○	○	○	○	○	○	○	○	○							
Shaft Protecting Sleeve													●	○	○	○			○
Mechanical Seal (*)	EN 12756																		

(*) Optional :Depending on customer requirement or request different types and brands of mechanical seals are applicable.

● Standard manufacturing
○ Optional

Material Equivalents

Description	DIN / EN		AISI / SAE / ASTM
Cast Iron	0.6025	EN-GJL-250 (GG25)	A48 Class 40B
Nodular Cast Iron	0.7040	EN-GJS-400-15 (GGG40)	A536 60-40-18
Cast Steel	1.0619	GP240GHGS-C25	A216 WCB
Chrome Nickel Cast Steel	1.4308	GX5CrNi19-10	A351 CF8
Chrome Nickel Cast Steel (low carbon)	1.4309	GX2CrNi19-11	A351 CF3
Chrome Nickel Molybdenum Cast Steel	1.4408	GX5CrNiMo19-11-2	A351 CF8M
Chrome Nickel Molybdenum Cast Steel (low carbon)	1.4409	GX2CrNiMo19-11-2	A351 CF3M
Austenitic Cast Steel	1.4500	GX7NiCrMoCuNb25-20	A351 CN7M
Austenitic - Ferritic Cast Steel (duplex)	1.4517	GX2CrNiMoCuN25-6-3-3	A890 CD4MCuN
Austenitic - Ferritic Cast Steel (super duplex)	1.4469	GX2CrNiMoN26-7-4	A890 CE3MN
Martenzitic Stainless Cast Steel	1.4317	GX4CrNi13-4	A352 CA6NM
Martenzitic Stainless Cast Steel	1.4008	GX7CrNiMo12-1	A217 CA15
Chrome Steel	1.4021	X20Cr13	A276 Type 420
Chrome Steel(heat treated)	1.4021	X20Cr13	A276 Type 420+QT
Chrome Nickel Steel	1.4301	X5CrNi18-10	A276 Type 304
Chrome Nickel Steel (low carbon)	1.4404	X2CrNiMo17-12-2	A276 Type 316L
Duplex (austenitic-ferritic) Steel	1.4460	X3CrNiMoN27-5-2	AISI 329
Duplex (austenitic-ferritic) Steel	1.4462	X2CrNiMoN22-5-3	UNS S32205

Flange Dimensions

DNe/DNb	Suction & Discharge (PN 16)			
	Df	k	s	n
32	140	100	19	4
40	150	110	19	4
50	165	125	19	4
65	185	145	19	4
80	200	160	19	8
100	220	180	19	8
125	250	210	19	8
150	285	240	23	8
200	340	295	23	12
250	405	355	28	12
300	460	410	28	12

" n " number of holes

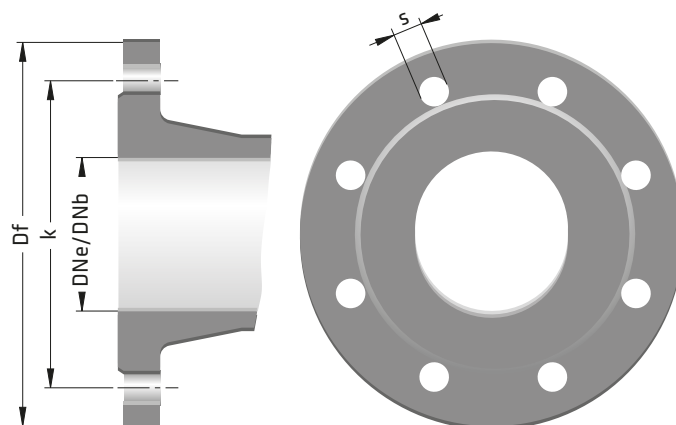



Pump • Fire Fighting Units • Booster Set

SPO

API 610 11th Edition ISO 13709 Process Pumps



Kalasanati.com



Application Areas and Pumped Liquids

Petroleum industry, power plants and chemical industry. Fuel oil, motorin, gasoline, LPG, lubricants, kerosene, etc.

Technical Data

Discharge Flange _____ NPS 1" -NPS 10"

Capacity _____ up to 1000 m³/h

Head _____ up to 350 m

Speed _____ up to 3600 m

Design Temperature _____ up to +350 °C(*)

Design Pressure _____ 51 bar (*)

Design Type _____ OH2

(*) The Material of pump differs according to the type of pumped liquid, operating temperature and pressure. Contact for detailed information.

Design Features

- According to API 610 11th edition (ISO 13709).
- Center line volute casing design for high pressure and temperature.
- Tangential outlet design for high efficiency at the volute casing.
- For special application double volute casing can be applied.
- Due to the back-pull-out design, the complete bearing assembly including impeller and casing cover can be dismantled without removing the volute casing from the pipe system. With spacer coupling application, also possible to take out the rotor group without dismantling the electric motor.

Pump Designation

Pump Type _____

Discharge Nozzle (inch) _____

Suction Nozzle (inch) _____

Nominal Impeller Diameter (inch) _____

- The suction and discharge flanges are capable for handling the forces and moments which are mentioned in API 610.
- The material of casing gasket is spiral wound gasket for handling high pressure.
- In case of pumping hot liquid there is cooling devices on bearing housing and special construction for mechanical seal.
- Heavy duty type shaft and bearings.
- All impellers are balanced dynamically or statically according to ISO 1940 grade 2.5.
- In case of preventive maintenance, temperature and vibration sensors can be applied.
- For high bearing life time, the constant level oilers are supplied in order to keep oil level in proper level.
- Oil ring is used in standart production and these rings prevent oil foaming.
- The base plate construction is highly rigid as defined in to API 610 standard.

Shaft Sealing

- Mechanical seal cover is designed according to API 610. This mechanical seal cover is suitable to assemble every kind of mechanical seal according to API 682.

SPO 6 - 4 - 17

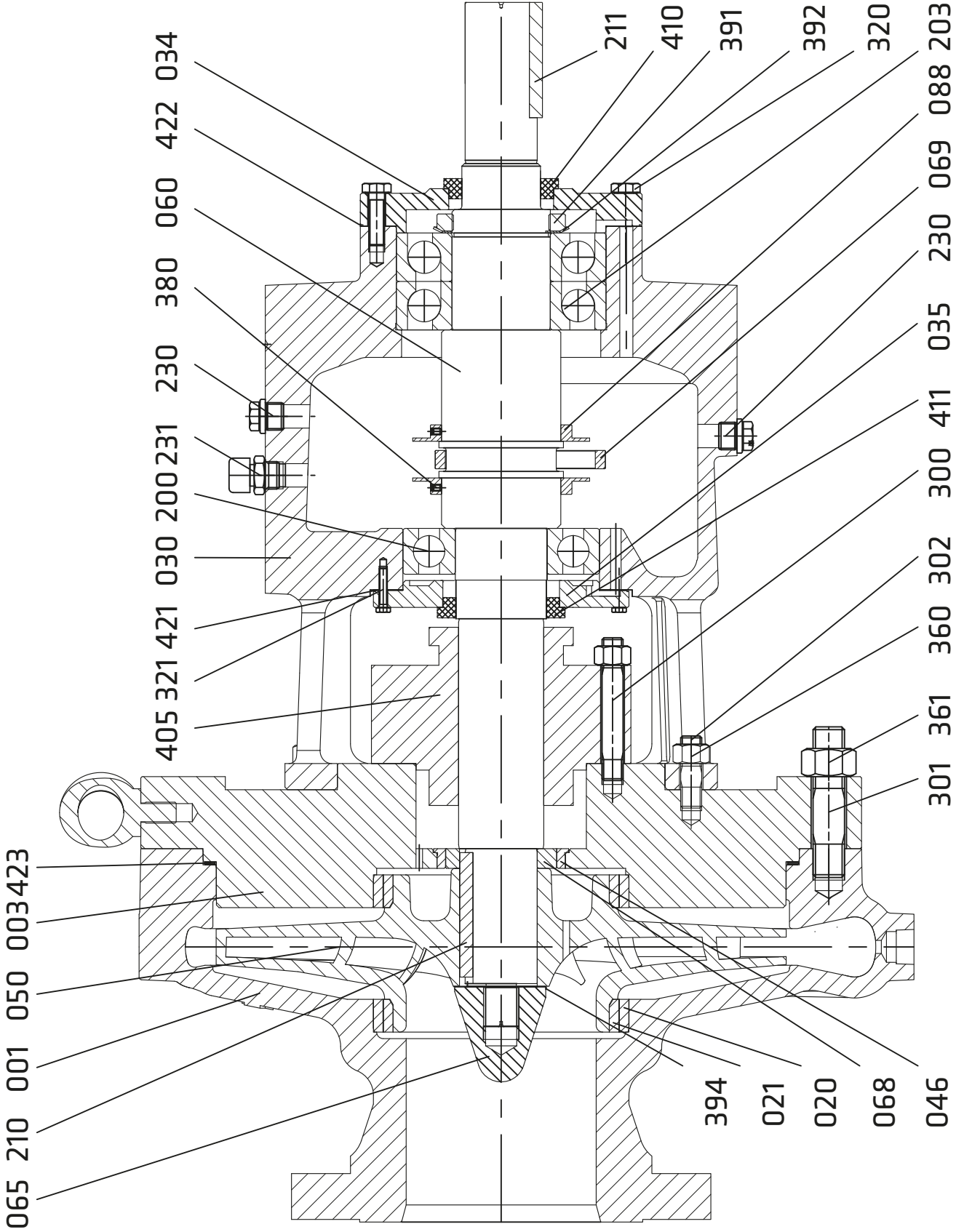



423	CASING GASKET	230	SCREW
422	GASKET	211	COUPLING KEY
421	GASKET	210	IMPELLER KEY
411	LIP SEAL	203	ANGULAR BALL BEARING
410	LIP SEAL	200	BALL BEARING
405	MECHANICAL SEAL	088	THROWER
394	LOCK WASHER	069	OIL RING
392	LOCK WASHER	068	SHAFT SLEEVE
391	LOCK NUT	065	IMPELLER NUT
380	SETSCREW	060	SHAFT
361	CASING NUT	050	IMPELLER
360	NUT	046	THROUTLING BUSH
321	SCREW	035	BEARING COVER
320	SCREW	034	BEARING COVER
302	STUD	030	BEARING HOUSING
301	CASING STUD	021	WEAR RING (CASING COVER)
300	STUD	020	WEAR RING (CASING)
231	OIL FILLING PLUG AND BREATHER	003	CASING COVER
		001	VOLUTE CASING

Material Options

Part No		API 610 MATERIAL CLASS				
		S-5	S-6	S-8	C-6	A-8
001	VOLUTE CASING	STEEL			%12 Chrome	316 SS
050	IMPELLER	STEEL	%12 Chrome	316 SS	%12 Chrome	316 SS
003	CASING COVER	STEEL			%12 Chrome	316 SS
060	SHAFT	AISI 4140		316 SS	420 SS	316 SS
030	BEARING HOUSING	STEEL				
065	IMPELLER NUT	STEEL	316 SS			
034	BEARING COVER	STEEL				
035	BEARING COVER	STEEL				
069	OIL RING	Bronze				
411	LIP SEAL	Bronze / Viton				
410	LIP SEAL	Bronze / Viton				
046	THROUTLING BUSH	420 SS		316 SS	420 SS	316 SS
020	WEAR RING (CASING)	%12 Chrome	%12 Chrome	316 SS	%12 Chrome	316 SS
021	WEAR RING (CASING COVER)	%12 Chrome	%12 Chrome	316 SS	%12 Chrome	316 SS
423	CASING	316 SS Spiral Wound				
301/361	STUD AND NUT (CASING)	AISI 4140				





Pump • Fire Fighting Units • Booster Set

SNMV-H

VERTICAL CENTRIFUGAL PUMPS



Kalasanati.com



Handled Liquids

Clean or slightly contaminated low viscosity liquids without solid & fibrous particles.

Technical Data

Discharge Flange _____ DN 32.....DN 250 mm

Capacity _____ up to 1400 m³/h

Head _____ up to 100 m

Speed _____ up to 2900 rpm

Design Temperature _____ -10 °C' to +140 °C*

Casing Pressure (Pmax) _____ 10 bar (16 bar)*

(Pmax: Suction Pressure + Shut off Head)

(*) The Material of pumps differ according to the type of pumped liquid, operating temperature and pressure. Contact for detailed information.

Design Features

- Vertical, radially split volute casing type, single stage, end suction centrifugal pump with closed impeller.
- Volute casing main dimensions comply with EN 733.
- Suction and discharge flanges conform to EN 1092-2 / PN 16. (EN 1092-1 / PN 16 for steel or stainless steel casing)

Pump Designation

Pump Type _____

Discharge Nozzle (DN-mm) _____

Nominal Impeller Diameter (mm) _____

- Due to the back-pull-out design, the complete bearing assembly including impeller and casing cover can be dismantled without removing the volute casing from the pipe system. (With spacer coupling application, also possible to take out the rotor group without dismantling the electric motor.)

- All impellers are balanced dynamically or statically according to ISO 1940 class 6.3.

- Axial thrust is balanced by impeller balancing holes system.

- Direction of rotation is clockwise viewed from drive end.

- Bearings of SNMV-H type pumps are "life time grease lubricated" ball bearings.

Shaft Sealing

- In standard production mechanical seals are used according to pumped liquid and working conditions.

SNMV-H 125 - 315



Kalasanati.com

1450 rpm

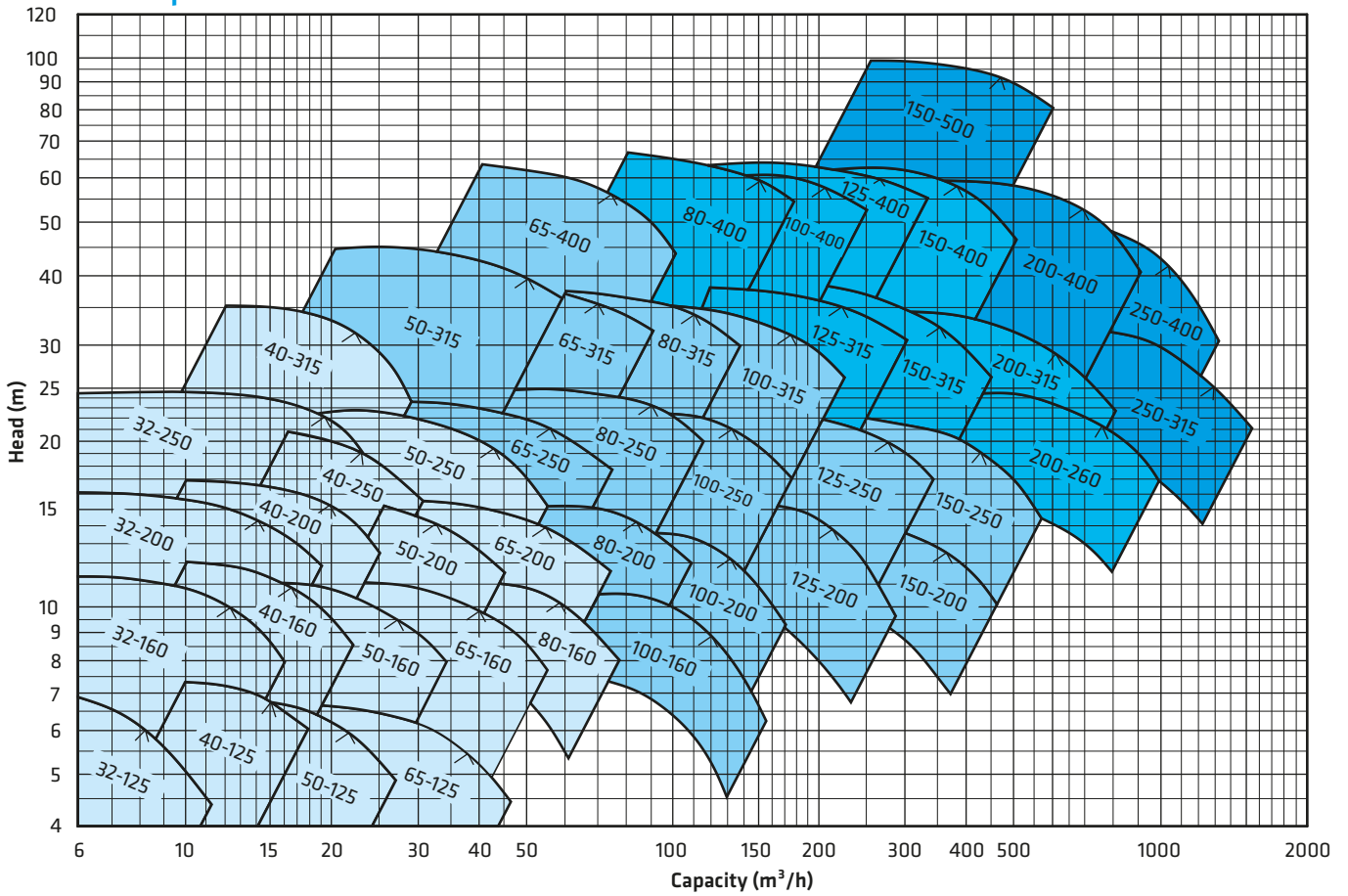

2900 rpm

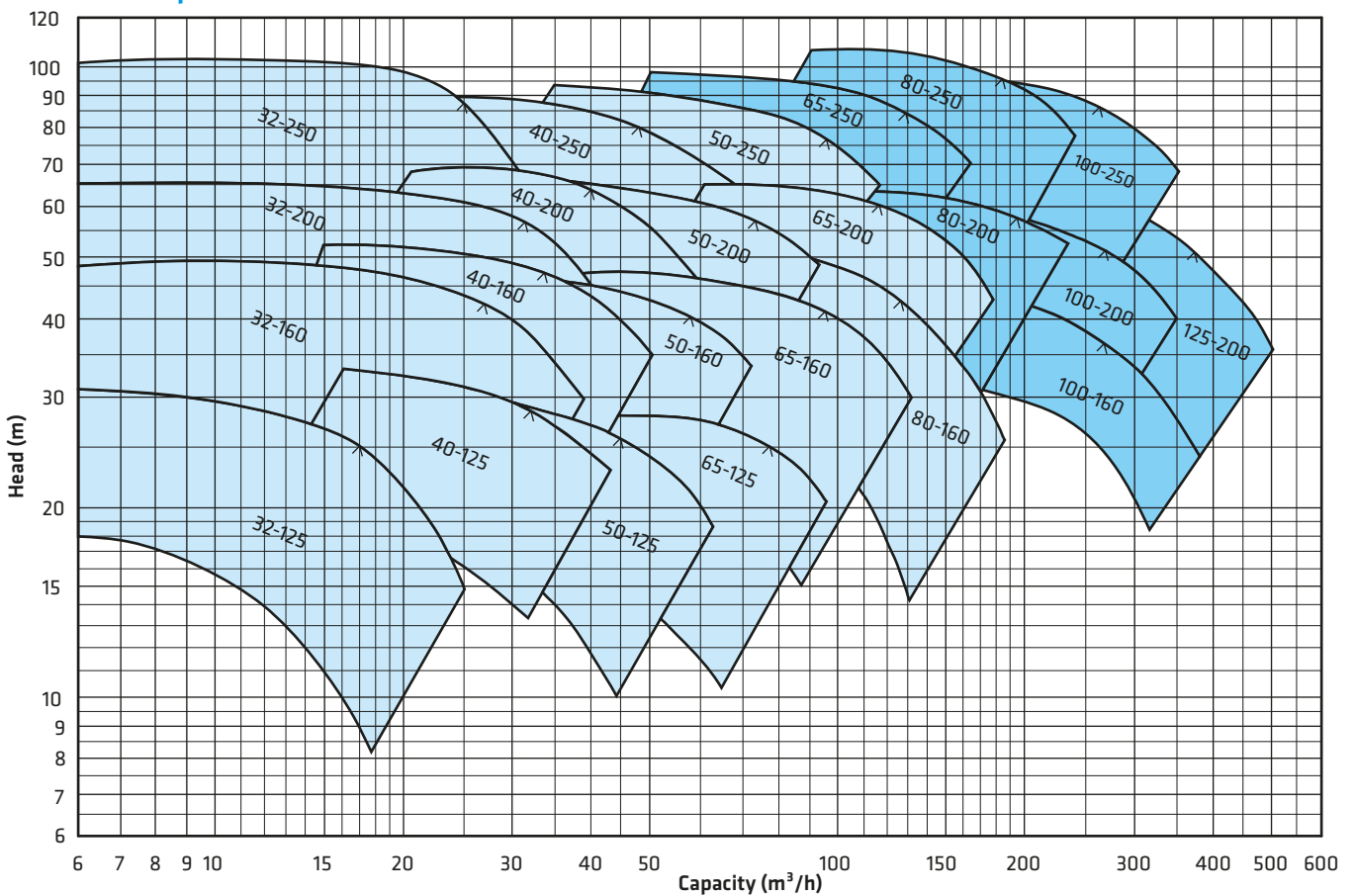



Part List

001	Volute Casing
003	Casing Cover
011	Elbow Foot
012	Motor Pedestal
030	Bearing Housing
034	Bearing Cover
035	Bearing Cover
050	Impeller
060	Pump Shaft
065	Impeller Nut
067	Spacer Sleeve
086	Coupling Rubber
087	Flexible Coupling
088	Thrower
200	Ball Bearing
210	Impeller Key
211	Coupling Key
230	Drain Plug
405	Mechanical Seal
410	Lip Seal
420	O-Ring
600	Electric Motor

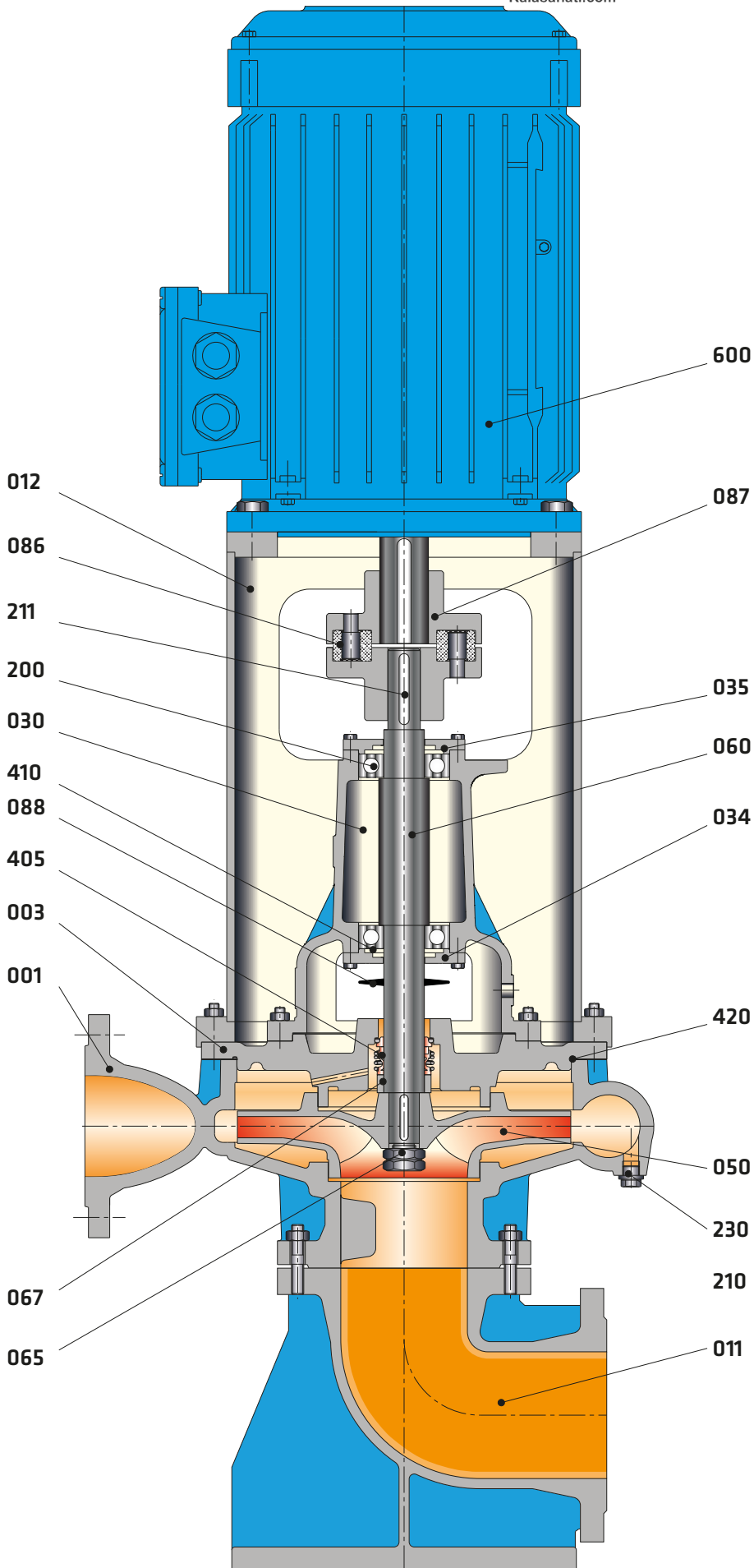



Kalasanati.com

Technical Data

Part List	10	30	35	20	60	6L	70	7L	8M	7D	7S	8N	80	4C	4A	40	80	8T	60	7L	7E	7D	
	0.6025	0.7040	0.7043	1.0619	1.4308	1.4309	1.4408	1.4409	1.4500	1.4517	1.4469	1.4317	1.4008	2.1050.01	2.0975.01	2.1096.01	1.4021	1.4021+QT	1.4301	1.4404	1.4460	1.4462	
Volute Casing	●	○	○	○	○	○	○	○	○	○	○	○	○	○									
Casing Cover	●	○	○	○	○	○	○	○	○	○	○	○	○	○									
Impeller	●	○	○	○	○	○	○	○	○	○	○	○	○	○	○	○						○	
Shaft																	●	○	○	○			○
Bearing Housing	●	○	○	○	○	○	○	○															
Mechanical Seal (*)	EN 12756																						

(*) Optional :Depending on customer requirement or request different types and brands of mechanical seals are applicable.

● Standard manufacturing
○ Optional

Material Equivalents

Description	DIN / EN		AISI / SAE / ASTM
Cast Iron	0.6025	EN-GJL-250 (GG25)	A48 Class 40B
Nodular Cast Iron	0.7040	EN-GJS-400-15 (GGG40)	A536 60-40-18
Nodular Cast Iron	0.7043	EN-GJS-400-18-LT (GGG40.3)	A536 60-40-18
Cast Steel	1.0619	GP240GHGS-C25	A216 WCB
Chrome Nickel Cast Steel	1.4308	GX5CrNi19-10	A351 CF8
Chrome Nickel Cast Steel (low carbon)	1.4309	GX2CrNi19-11	A351 CF3
Chrome Nickel Molybdenum Cast Steel	1.4408	GX5CrNiMo19-11-2	A351 CF8M
Chrome Nickel Molybdenum Cast Steel (low carbon)	1.4409	GX2CrNiMo19-11-2	A351 CF3M
Austenitic Cast Steel	1.4500	GX7NiCrMoCuNb25-20	A351 CN7M
Austenitic - Ferritic Cast Steel (duplex)	1.4517	GX2CrNiMoCuN25-6-3-3	A890 CD4MCuN
Austenitic - Ferritic Cast Steel (super duplex)	1.4469	GX2CrNiMoN26-7-4	A890 CE3MN
Martenzitic Stainless Cast Steel	1.4317	GX4CrNi13-4	A352 CA6NM
Martenzitic Stainless Cast Steel	1.4008	GX7CrNiMo12-1	A217 CA15
Cast Bronze (tin alloy)	2.1050.01	G-CuSn10	B427 C90700
Cast Bronze (nickel alloy)	2.0975.01	G-CuAl10Ni	B148 C95500
Cast Bronze (lead)	2.1096.01	G-CuSn5ZnPb	B584 C83600
Chrome Steel	1.4021	X20Cr13	A276 Type 420
Chrome Steel(heat treated)	1.4021	X20Cr13	A276 Type 420+QT
Chrome Nickel Steel	1.4301	X5CrNi18-10	A276 Type 304
Chrome Nickel Steel (low carbon)	1.4404	X2CrNiMo17-12-2	A276 Type 316L
Duplex (austenitic-ferritic) Steel	1.4460	X3CrNiMoN27-5-2	AISI 329
Duplex (austenitic-ferritic) Steel	1.4462	X2CrNiMoN22-5-3	UNS S32205

Flange Dimensions

DNe/DNb	Suction & Discharge (PN 16)			
	Df	k	s	n
32	140	100	19	4
40	150	110	19	4
50	165	125	19	4
65	185	145	19	4
80	200	160	19	8
100	220	180	19	8
125	250	210	19	8
150	285	240	23	8
200	340	295	23	12
250	405	355	28	12
300	460	410	28	12

EN 1092 - 2

“ n “ number of holes

SNLV-H IN-LINE PUMPS



Handled Liquids

Clean or slightly contaminated low viscosity liquids without solid & fibrous particles.

Technical Data

Discharge Flange _____ DN 40.....DN 250 mm

Capacity _____ up to 800 m³/h

Head _____ up to 95 m

Speed _____ up to 2900 rpm

Design Temperature _____ -10 °C' to +140 °C*

Casing Pressure (Pmax) _____ 10 bar (16 bar)*

(Pmax: Suction Pressure + Shut off Head)

(*) The Material of pumps differ according to the type of pumped liquid, operating temperature and pressure. Contact for detailed information.

Design Features

- Volute casing, single stage, vertical in-line centrifugal pump with closed impeller and with separate own bearing bracket.
- Suction and discharge flanges conform to EN 1092-2 / PN 16. (EN 1092-1 / PN 16 for steel or stainless steel casing)
- SNLV-H pumps are short coupled with electric motors of IEC frame sizes with high efficiency class.

Pump Designation

Pump Type _____
Suction and Discharge Nozzle (DN-mm) _____
Nominal Impeller Diameter (mm) _____

- Due to the back-pull-out design, the complete bearing assembly including impeller and casing cover can be dismantled without removing the volute casing from the pipe system. (With spacer coupling application, also possible to take out the rotor group without dismantling the electric motor.)

- All impellers are balanced dynamically or statically according to ISO 1940 class 6.3.

- Axial thrust is balanced by impeller balancing holes system.

- Direction of rotation is clockwise viewed from drive end.

- Bearings of SNLV-H type pumps are "life time grease lubricated" ball bearings.

Shaft Sealing

- Single mechanical seal, flushed by pumped liquid, uncooled and unbalanced.

SNLV-H 100 - 250



1450 rpm

Grouped according to mechanical seal dimension

- A
- B
- C
- D

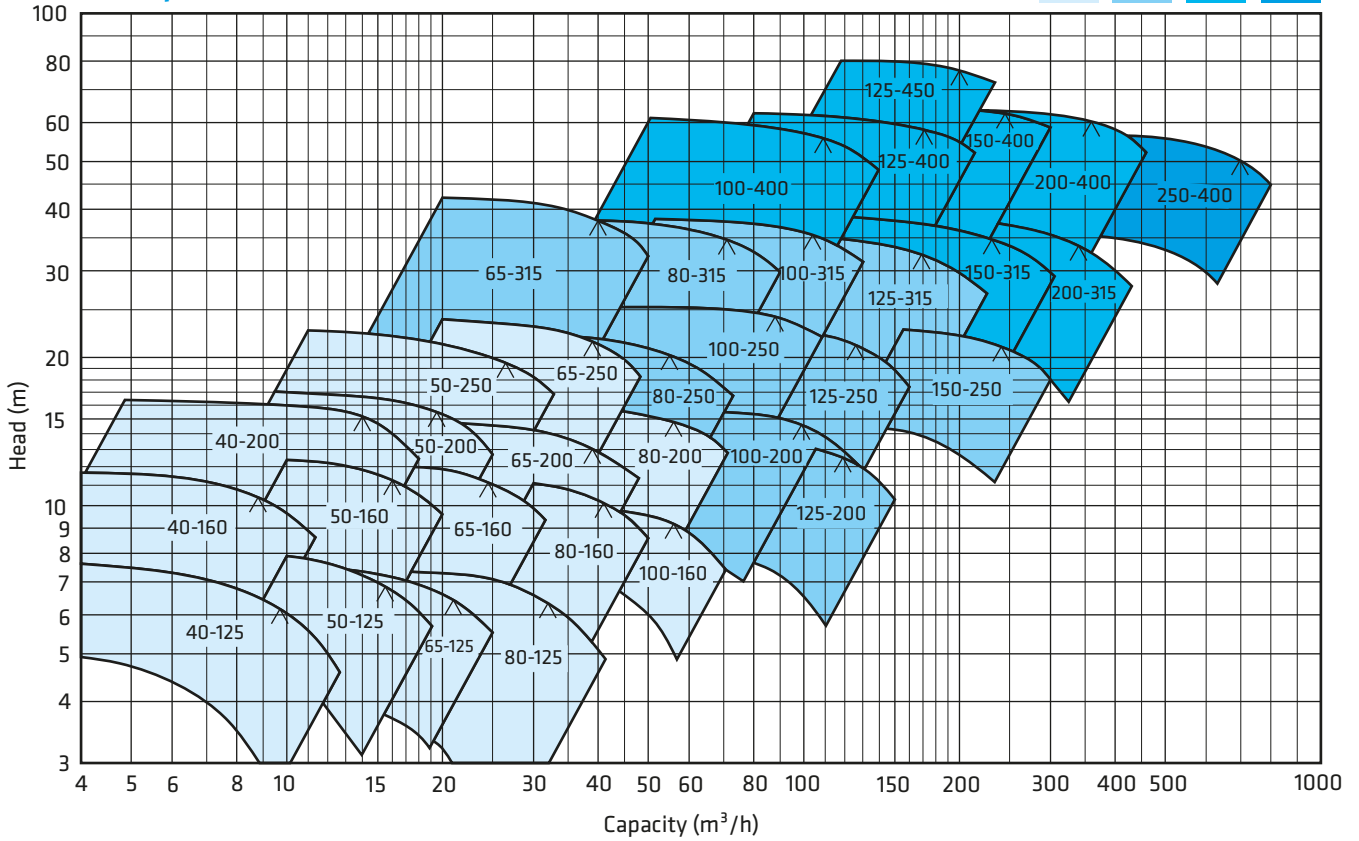

2900 rpm

Grouped according to mechanical seal dimension

- A
- B

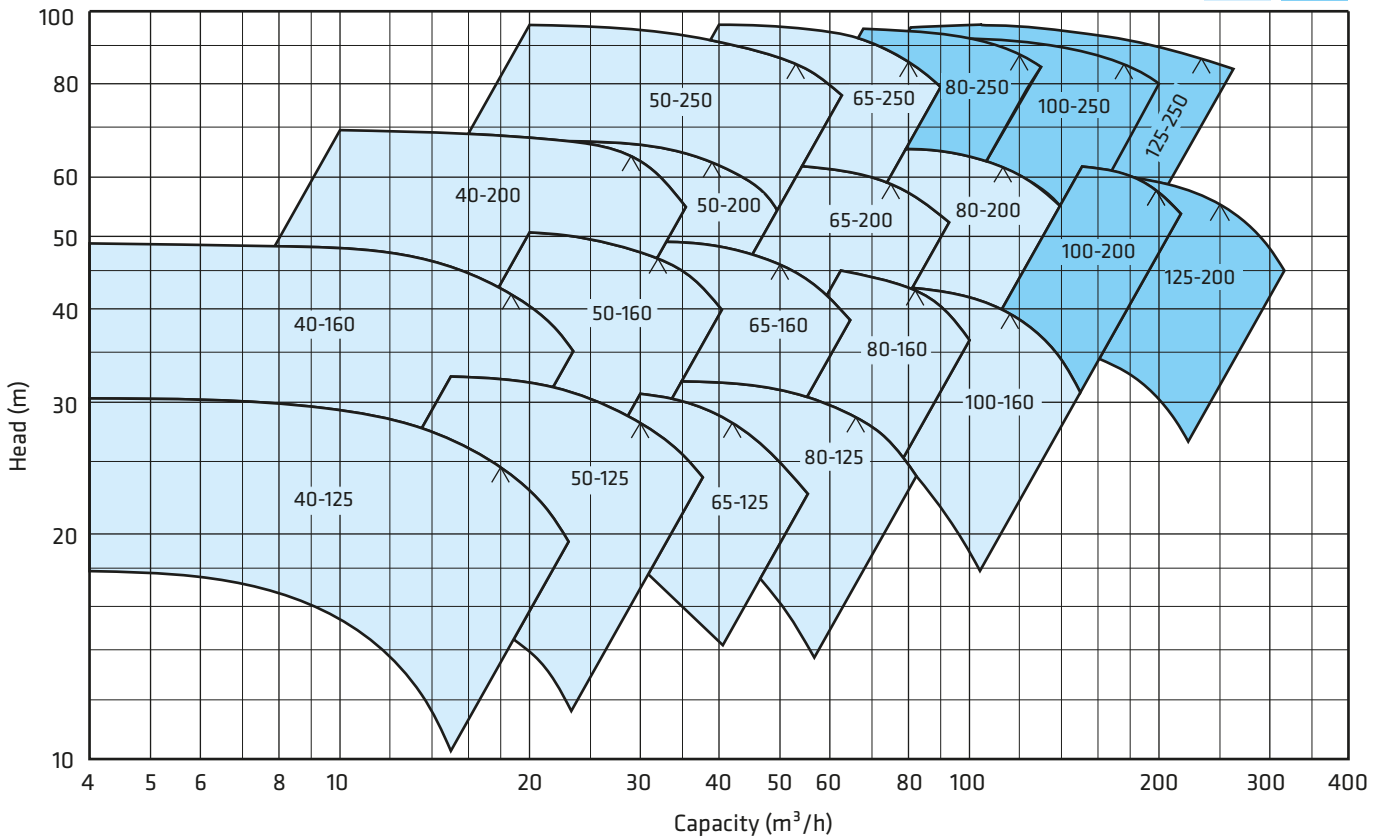

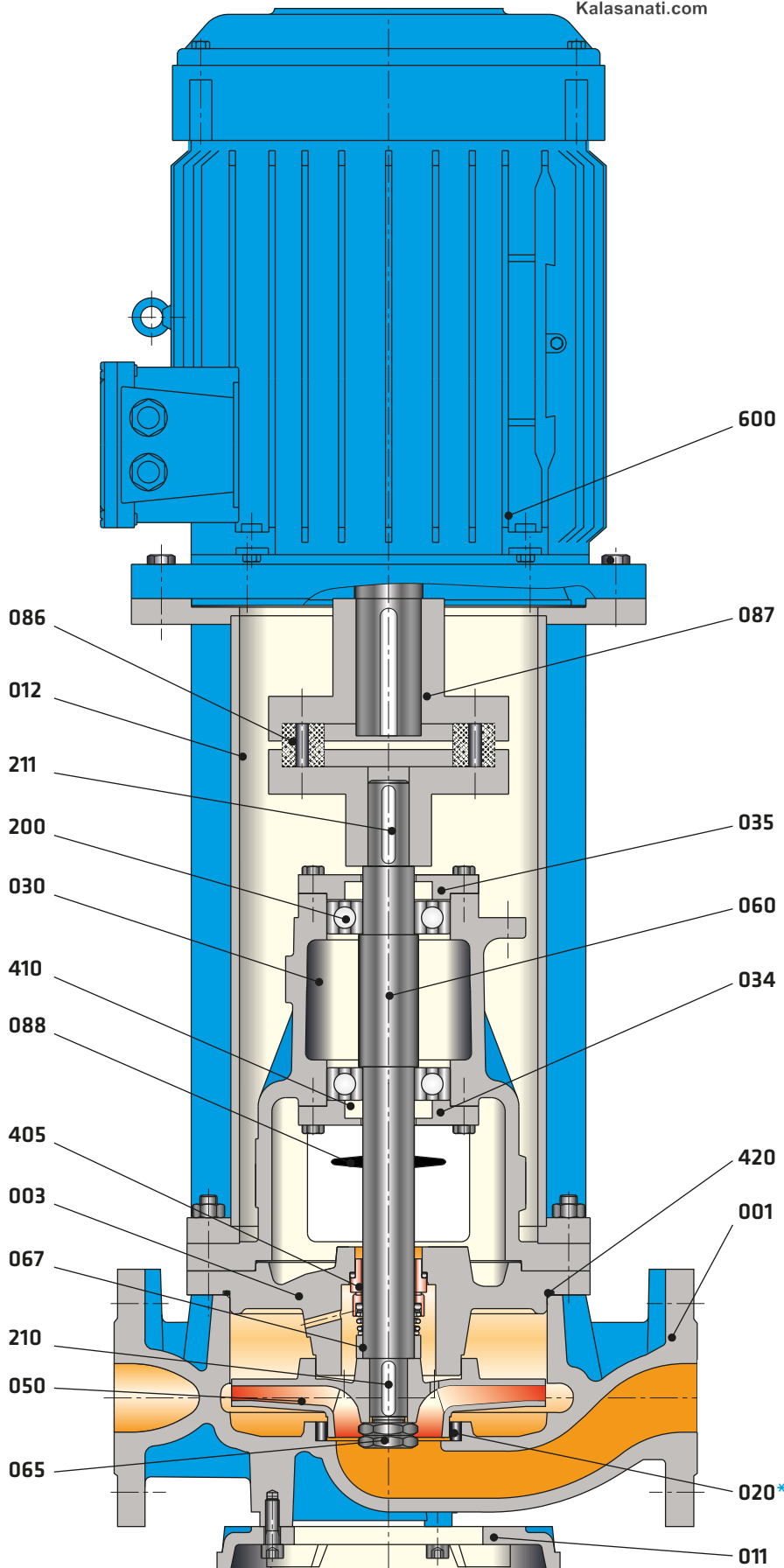

Part List

- 001 Volute Casing
- 003 Casing Cover
- 011 Base Plate
- 012 Motor Pedestal
- *020 Wear Ring
- 030 Bearing Bracket
- 034 Bearing Cover
- 035 Bearing Cover
- 050 Impeller
- 060 Pump Shaft
- 065 Impeller Nut
- 067 Spacer Sleeve
- 086 Coupling Rubber
- 087 Flexible Coupling
- 088 Thrower
- 200 Ball Bearing
- 210 Impeller Key
- 211 Coupling Key
- 405 Mechanical Seal
- 410 Lip Seal
- 420 O-Ring
- 600 Electric Motor

(*) Optional



Technical Data

PART LIST	10	30	35	20	60	6L	70	7L	8M	7D	7S	8N	80	4C	4A	40	80	8T	60	7L	7E	7D	
	0.6025	0.7040	0.7043	1.0619	1.4308	1.4309	1.4408	1.4409	1.4500	1.4517	1.4469	1.4317	1.4008	2.1050.01	2.0975.01	2.1096.01	1.4021	1.4021+QT	1.4301	1.4404	1.4460	1.4462	
Volute Casing	●	○	○	○	○	○	○	○	○	○	○	○	○	○	○	○	○	○	○	○	○	○	○
Casing Cover	●	○	○	○	○	○	○	○	○	○	○	○	○	○	○	○	○	○	○	○	○	○	○
Impeller	●	○	○	○	○	○	○	○	○	○	○	○	○	○	○	○	○	○	○	○	○	○	○
Shaft																	●	○	○	○	○	○	○
Bearing Housing	●	○	○	○	○	○	○	○															
Wear Ring	○	○	○	○	○	○	○	○	○	○	○	○	○	○	○	○	○	○	○	○	○	○	○
Mechanical Seal (*)	EN 12756																						

(*) Optional :Depending on customer requirement or request different types and brands of mechanical seals are applicable.

● Standard manufacturing
○ Optional

Material Equivalents

Description	DIN / EN		AISI / SAE / ASTM
Cast Iron	0.6025	EN-GJL-250 (GG25)	A48 Class 40B
Nodular Cast Iron	0.7040	EN-GJS-400-15 (GGG40)	A536 60-40-18
Nodular Cast Iron	0.7043	EN-GJS-400-18-LT (GGG40.3)	A536 60-40-18
Cast Steel	1.0619	GP240GHGS-C25	A216 WCB
Chrome Nickel Cast Steel	1.4308	GX5CrNi19-10	A351 CF8
Chrome Nickel Cast Steel (low carbon)	1.4309	GX2CrNi19-11	A351 CF3
Chrome Nickel Molybdenum Cast Steel	1.4408	GX5CrNiMo19-11-2	A351 CF8M
Chrome Nickel Molybdenum Cast Steel (low carbon)	1.4409	GX2CrNiMo19-11-2	A351 CF3M
Austenitic Cast Steel	1.4500	GX7NiCrMoCuNb25-20	A351 CN7M
Austenitic - Ferritic Cast Steel (duplex)	1.4517	GX2CrNiMoCuN25-6-3-3	A890 CD4MCuN
Austenitic - Ferritic Cast Steel (super duplex)	1.4469	GX2CrNiMoN26-7-4	A890 CE3MN
Martenzitic Stainless Cast Steel	1.4317	GX4CrNi13-4	A352 CA6NM
Martenzitic Stainless Cast Steel	1.4008	GX7CrNiMo12-1	A217 CA15
Cast Bronze (tin alloy)	2.1050.01	G-CuSn10	B427 C90700
Cast Bronze (nickel alloy)	2.0975.01	G-CuAl10Ni	B148 C95500
Cast Bronze (lead)	2.1096.01	G-CuSn5ZnPb	B584 C83600
Chrome Steel	1.4021	X20Cr13	A276 Type 420
Chrome Steel(heat treated)	1.4021	X20Cr13	A276 Type 420+QT
Chrome Nickel Steel	1.4301	X5CrNi18-10	A276 Type 304
Chrome Nickel Steel (low carbon)	1.4404	X2CrNiMo17-12-2	A276 Type 316L
Duplex (austenitic-ferritic) Steel	1.4460	X3CrNiMoN27-5-2	AISI 329
Duplex (austenitic-ferritic) Steel	1.4462	X2CrNiMoN22-5-3	UNS S32205

Flange Dimensions

DNe/DNb	Suction & Discharge (PN 16)			
	Df	k	s	n
40	150	110	19	4
50	165	125	19	4
65	185	145	19	4
80	200	160	19	8
100	220	180	19	8
125	250	210	19	8
150	285	240	23	8
200	340	295	23	12
250	405	355	28	12

" n " number of holes

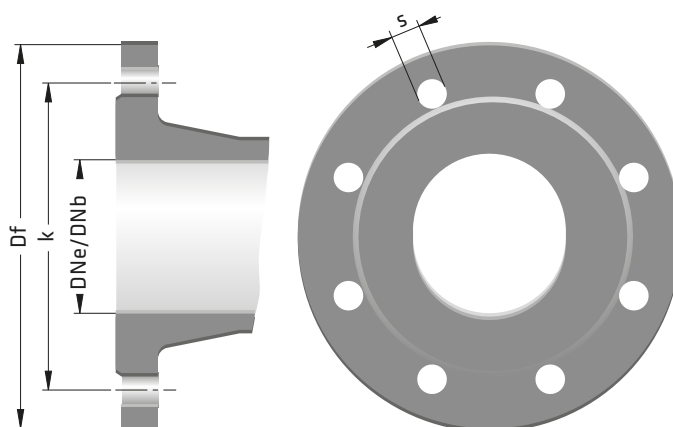



Pump • Fire Fighting Units • Booster Set

SDS / SDS-V DOUBLE SUCTION PUMPS



Kalasanati.com



Handled Liquids

Clean or slightly contaminated low viscosity liquids without solid & fibrous particles.

Technical Data

- Discharge Flange _____ DN 65.....DN 600 mm
- Capacity _____ up to 6000 m³/h
- Head _____ up to 180 m
- Speed _____ up to 2900 rpm
- Design Temperature _____ -10 °C' to +110 °C*
- Casing Pressure (Pmax) _____ 16 bar - 25 bar*

(Pmax: Suction Pressure + Shut off Head)

(*) The Material of pumps differ according to the type of pumped liquid, operating temperature and pressure. Contact for detailed information.

Design Features

- Horizontal or vertical manufacturing option. Axial split case, single stage, double suction centrifugal pumps.
- Suction and discharge flanges are on the same axis on the bottom casing. Split case design permits easy disassembly of the rotor group for maintenance or repair without distorting pump alignment and suction / discharge piping.
- Suction and Discharge Flanges are conform to EN 1092-2/PN 16 or PN25. (EN 1092-1 / PN 16 or PN 25 for steel or stainless steel casing)

Pump Designation

- Pump Type _____
- Vertical Installation _____
- Discharge Nozzle (DN-mm) _____
- Nominal Impeller Diameter (mm) _____

SDS - V 200 - 500

•All impellers are balanced dynamically or statically according to ISO 1940 class 6.3.

•Impeller is of double suction design. This feature increases pump suction performance in addition with providing the balance of hydraulic axial forces resulting higher bearing lifes and higher reliability.

•In standard construction, the direction of rotation is clockwise when it is looked from drive end. In this case, suction flange is on right and discharge flange is on left. Upon request the direction of rotation can be reversed. This time the position of the suction and discharge flanges are also reversed.

•Grease lubricated ball bearings are used in horizontal installation. In case of vertical installation, pumping liquid lubricated journal bearings on top and grease lubricated ball bearings on bottom are used.

Shaft Sealing

•Depending on request or requirement, pumps with soft packing or single, double and cartridge type mechanical seals can be supplied.

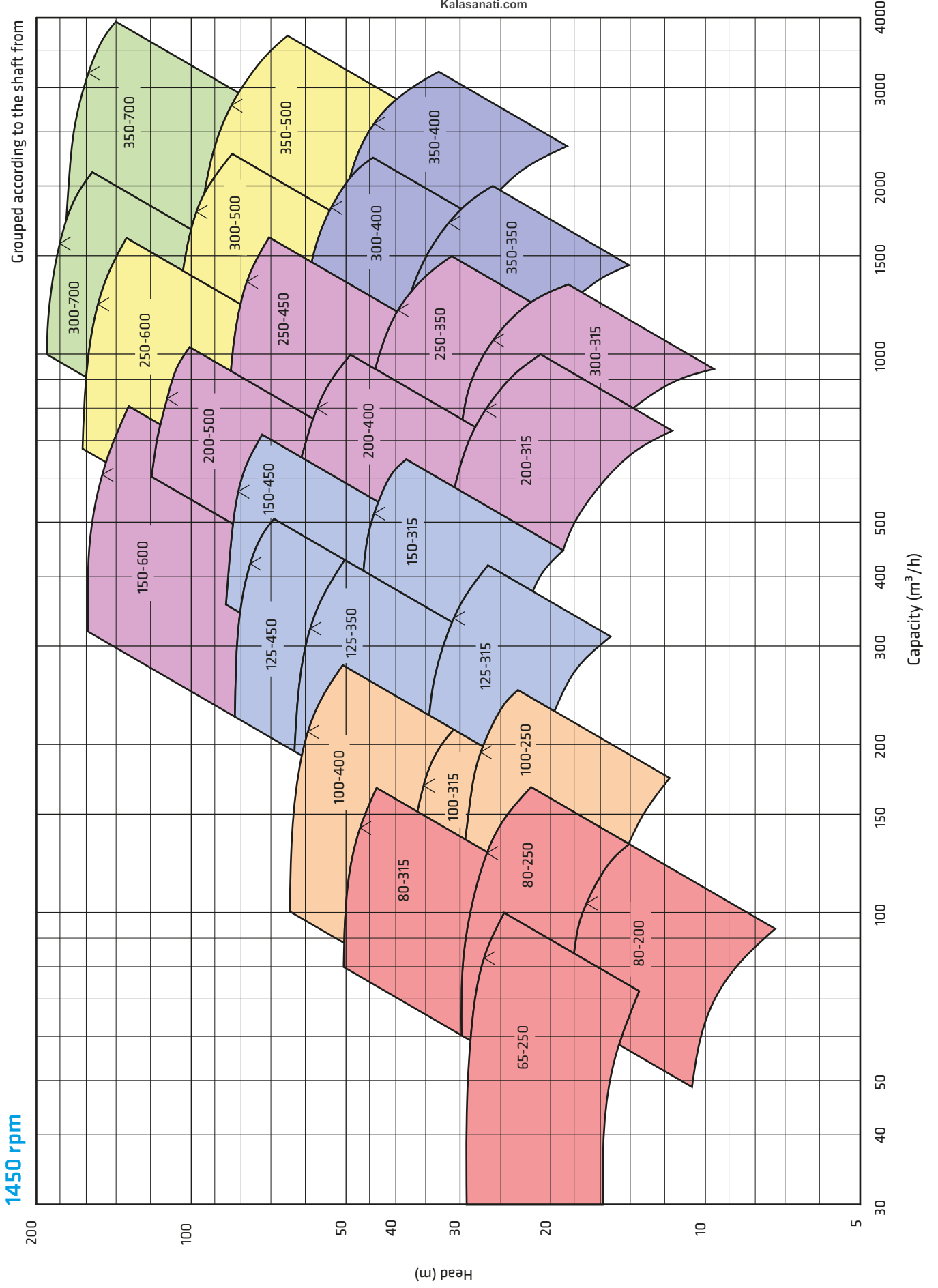

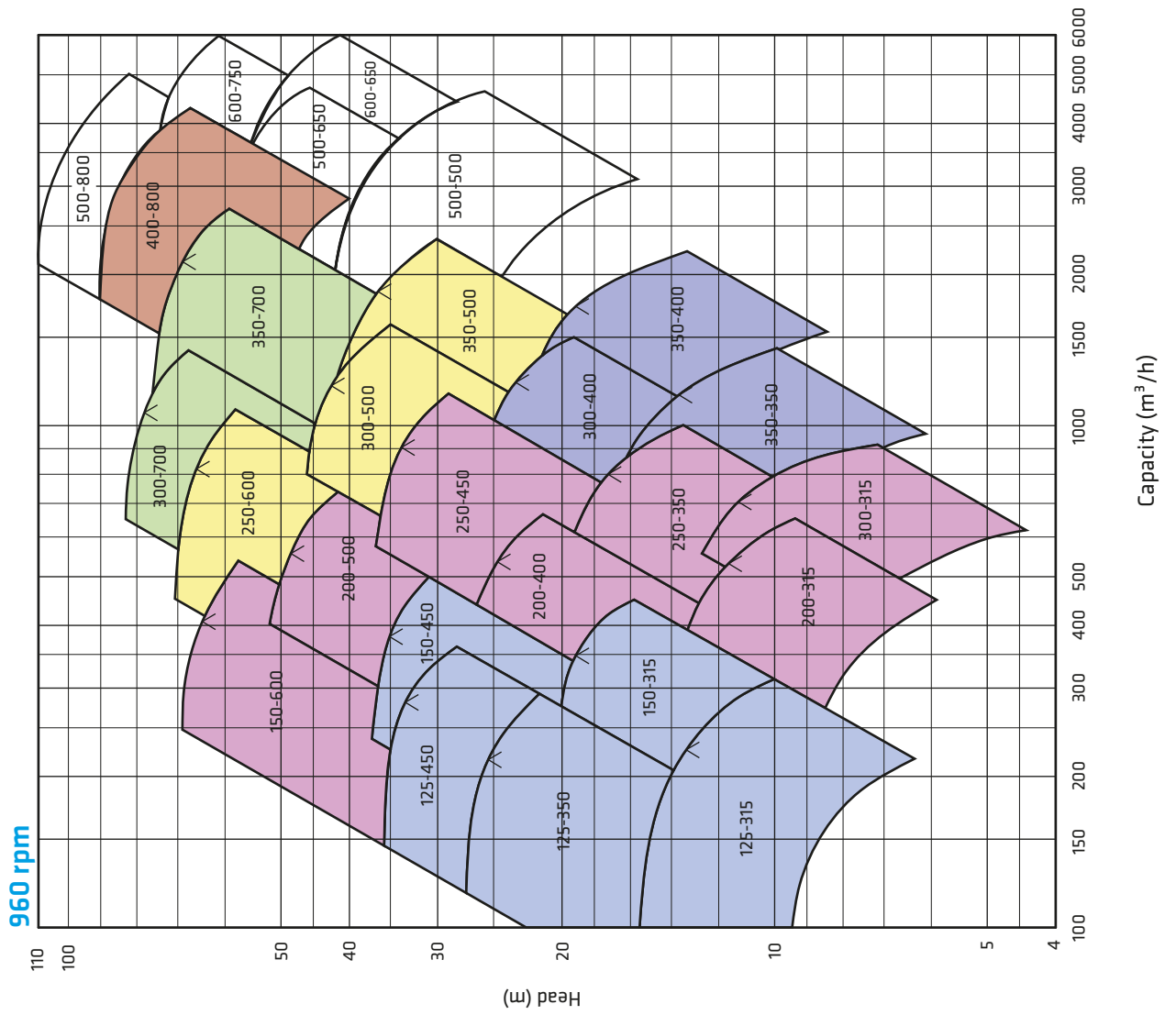
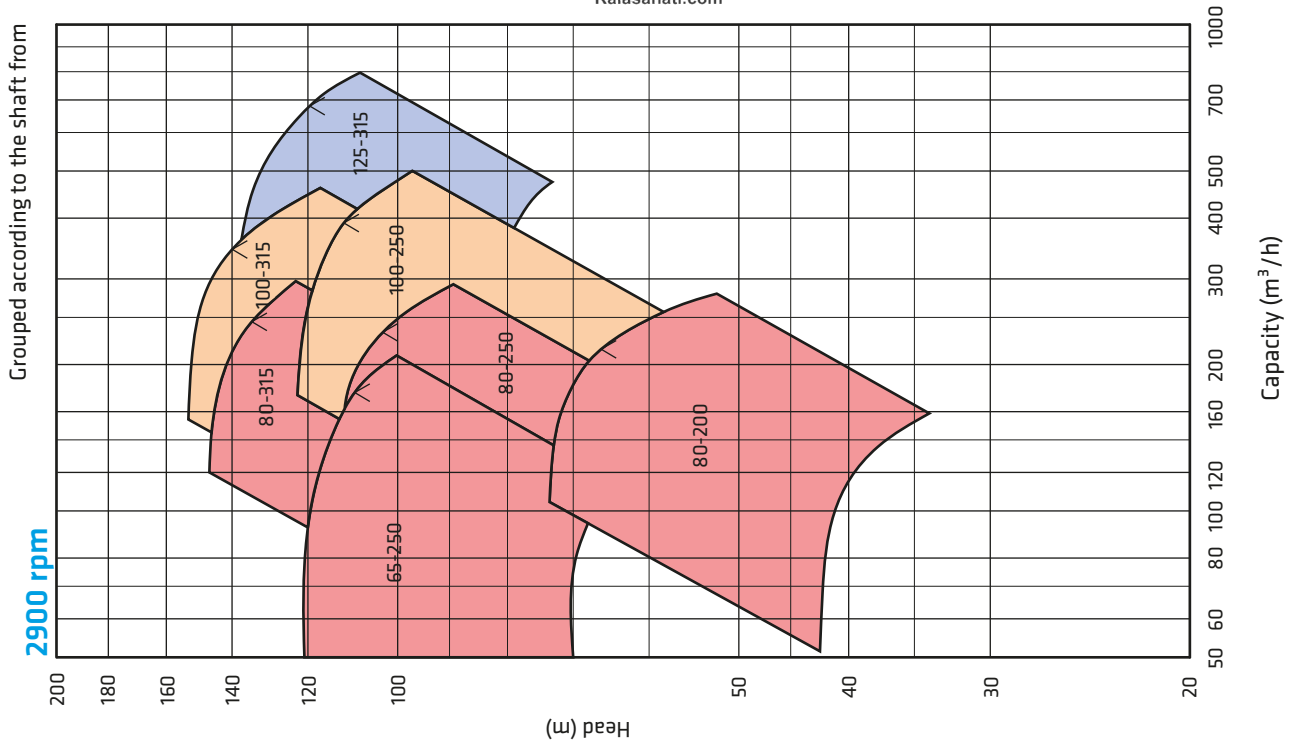



* Mechanical Seal Application

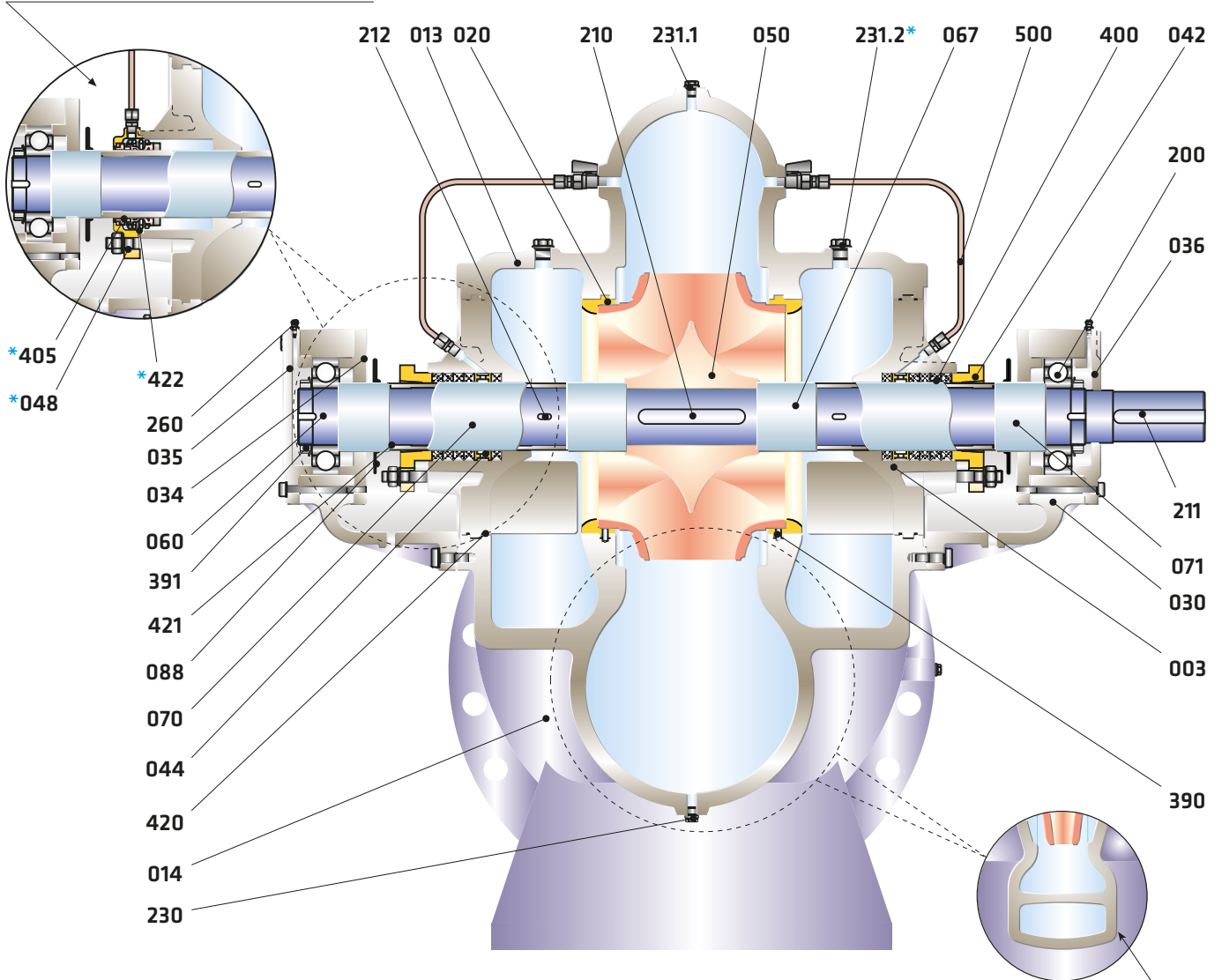

Part List

003	Stuffing Box	200	Ball Bearing
013	Volute Casing (top half)	210	Impeller Key
014	Volute Casing (bottom half)	211	Coupling Key
020	Wear Ring	212	Spacer Sleeve Key
030	Bearing Bracket	230	Drain Plug
034	Bearing Cover (inboard)	231.1	Air Plug
035	Bearing Cover (outboard)	*231.2	Air Plug
036	Bearing Cover (coupling)	260	Grease Nipple
042	Stuffing Box Gland	390	Pin
044	Lantern Ring	391	Shaft Nut & Lock Washer
*048	Mechanical Seal Cover	400	Stuffing Box Packing
050	Impeller	*405	Mechanical Seal
060	Pump Shaft	420	O-Ring
067	Spacer Sleeve	421	O-Ring
070	Shaft Protecting Sleeve	*422	O-Ring
071	Shaft Protecting Sleeve	500	Flushing Pipe
088	Thrower		

** Double Volute Application

(*) Optional

(**) Doble Volute Desing Is Applied to :

**SDS 200-500, 250-600,
300-500, 300-700,
350-500, 350-700**



Kalasanati.com

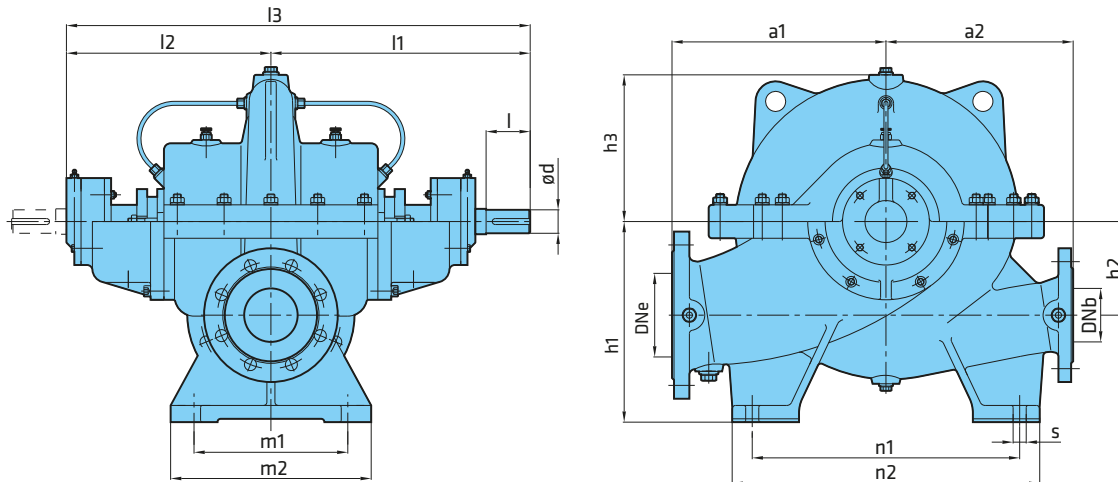

Pump Type	Dimensions (mm)																			Weight (kg)
	PNe	PNb	DNe	DNb	ød	l	l1	l2	l3	a1	a2	h1	h2	h3	n1	n2	m1	m2	s	
65-250	16	16	100	65	35	80	400	310	710	320	280	300	140	200	400	460	230	300	20	165
80-200	16	16	125	80	35	80	400	310	710	320	280	300	140	200	400	460	230	300	20	165
80-250	16	16	125	80	35	80	400	310	710	320	280	300	140	200	400	460	230	300	20	175
80-315	16	16	125	80	35	80	400	310	710	360	300	300	140	260	400	460	230	300	20	197
100-250	16	16	150	100	42	90	450	350	800	360	310	355	170	235	400	480	280	340	20	220
100-315	16	16	150	100	42	90	450	350	800	360	310	355	170	250	400	480	280	340	20	230
100-400	16	16	150	100	42	90	450	350	800	420	370	355	170	300	460	540	280	340	20	290
125-315	16	16	200	125	55	120	555	420	975	420	370	400	200	280	460	540	320	380	22	330
125-350	16	16	200	125	55	120	555	420	975	470	450	400	200	300	540	660	320	380	22	380
125-450	16	16	200	125	55	120	555	420	975	500	450	400	200	350	540	640	320	380	22	410
150-315	16	16	200	150	55	120	555	420	975	470	400	400	200	310	540	640	320	380	22	395
150-450	16	16	200	150	55	120	555	420	975	500	450	400	200	365	540	640	320	380	22	430
150-600	25	25	250	150	65	130	645	500	1145	550	500	560	300	445	540	640	360	420	22	800
200-315	16	16	250	200	65	130	645	500	1145	500	450	500	240	315	540	640	360	420	22	570
200-400	16	16	250	200	65	130	645	500	1145	500	450	500	240	360	540	640	360	420	22	575
200-500	16	16	250	200	65	130	645	500	1145	550	500	560	300	380	620	720	360	420	22	700
250-350	16	16	300	250	65	130	645	500	1145	600	500	600	300	390	620	720	360	420	22	682
250-450	16	16	300	250	65	130	645	500	1145	600	500	600	300	415	620	720	360	420	22	780
250-600	25	25	300	250	80	170	720	540	1260	650	550	600	300	430	620	710	415	485	26	1190
300-315	16	16	350	300	65	130	645	500	1145	600	500	630	300	400	620	700	360	420	22	700
300-400	16	16	400	300	75	140	770	615	1385	700	550	710	350	450	720	800	420	520	26	1125
300-500	16	16	400	300	85	170	755	585	1340	700	750	710	350	425	700	800	420	520	26	1500
300-700	25	25	400	300	100	180	865	675	1540	750	800	710	350	470	720	880	420	520	26	1650
350-350	16	16	400	350	75	140	770	615	1385	700	550	670	350	450	720	800	420	520	26	1100
350-400	16	16	500	350	75	140	770	615	1385	800	600	800	380	500	800	960	500	600	26	1400
350-500	16	16	500	350	80	170	755	585	1340	800	600	800	400	435	740	900	500	600	26	1435
350-700	25	25	500	350	100	180	865	675	1540	850	750	850	450	525	720	880	500	600	26	2000
400-800	16	16	600	400	105	220	1035	810	1845	900	900	880	450	565	950	1120	630	740	26	3400
500-500	16	16	600	500																
500-650	16	16	600	500																
500-800	16	16	600	500																
600-650	16	16	700	600																
600-750	16	16	700	600																

Contact for detailed information

Note: All rights reserved due to dimension change.



Kalasanati.com

Technical Data

PART LIST	10	30	35	20	60	6L	70	7L	8M	7D	7S	8N	80	4C	4A	40	80	8T	60	7L	7E	7D	
	0.6025	0.7040	0.7043	1.0619	1.4308	1.4309	1.4408	1.4409	1.4500	1.4517	1.4469	1.4317	1.4008	2.1050.01	2.0975.01	2.1096.01	1.4021	1.4021+QT	1.4301	1.4404	1.4460	1.4462	
Volute Casing(**)	●	○	○	○	○	○	○	○	○	○	○	○	○	○	○	○							
Impeller	●	○	○	○	○	○	○	○	○	○	○	○	○	○	○	○						○	
Shaft																	●	○	○	○			○
Bearing Housing	●	○	○	○	○	○	○	○															
Wear Ring (Casing)	●	○	○	○	○	○	○	○	○	○	○	○	○	○	○	○							
Shaft Protecting Sleeve																	●	○	○	○			○
Mechanical Seal (*)	EN 12756																						

(*) Optional :Depending on customer requirement or request different types and brands of mechanical seals are applicable.

● Standard manufacturing
○ Optional

(**) 0.7040 material is used in standard production for types which has PN 25 casing pressure class

Material Equivalents

Description	DIN / EN		AISI / SAE / ASTM
Cast Iron	0.6025	EN-GJL-250 (GG25)	A48 Class 40B
Nodular Cast Iron	0.7040	EN-GJS-400-15 (GGG40)	A536 60-40-18
Nodular Cast Iron	0.7043	EN-GJS-400-18-LT (GGG40.3)	A536 60-40-18
Cast Steel	1.0619	GP240GHGS-C25	A216 WCB
Chrome Nickel Cast Steel	1.4308	GX5CrNi19-10	A351 CF8
Chrome Nickel Cast Steel (low carbon)	1.4309	GX2CrNi19-11	A351 CF3
Chrome Nickel Molybdenum Cast Steel	1.4408	GX5CrNiMo19-11-2	A351 CF8M
Chrome Nickel Molybdenum Cast Steel (low carbon)	1.4409	GX2CrNiMo19-11-2	A351 CF3M
Austenitic Cast Steel	1.4500	GX7NiCrMoCuNb25-20	A351 CN7M
Austenitic - Ferritic Cast Steel (duplex)	1.4517	GX2CrNiMoCuN25-6-3-3	A890 CD4MCuN
Austenitic - Ferritic Cast Steel (super duplex)	1.4469	GX2CrNiMoN26-7-4	A890 CE3MN
Martenzitic Stainless Cast Steel	1.4317	GX4CrNi13-4	A352 CA6NM
Martenzitic Stainless Cast Steel	1.4008	GX7CrNiMo12-1	A217 CA15
Cast Bronze (tin alloy)	2.1050.01	G-CuSn10	B427 C90700
Cast Bronze (nickel alloy)	2.0975.01	G-CuAl10Ni	B148 C95500
Cast Bronze (Leaded)	2.1096.01	G-CuSn5ZnPb	B584 C83600
Chrome Steel	1.4021	X20Cr13	A276 Type 420
Chrome Steel(heat treated)	1.4021	X20Cr13	A276 Type 420+QT
Chrome Nickel Steel	1.4301	X5CrNi18-10	A276 Type 304
Chrome Nickel Steel (low carbon)	1.4404	X2CrNiMo17-12-2	A276 Type 316L
Duplex (austenitic-ferritic) Steel	1.4460	X3CrNiMoN27-5-2	AISI 329
Duplex (austenitic-ferritic) Steel	1.4462	X2CrNiMoN22-5-3	UNS S32205

Flange Dimensions

EN 1092 - 2	DNe/DNb	Suction & Discharge (PN 16)				Suction & Discharge (PN 25)			
		Df	k	s	n	Df	k	s	n
	65	185	145	19	4	185	145	19	8
	80	200	160	19	8	200	160	19	8
	100	220	180	19	8	235	190	23	8
	125	250	210	19	8	270	220	28	8
	150	285	240	23	8	300	250	28	8
	200	340	295	23	12	360	310	28	12
	250	405	355	28	12	425	370	31	12
	300	460	410	28	12	485	430	31	16
	350	520	470	28	16	555	490	34	16
	400	580	525	31	16	620	550	37	16
	500	715	650	34	20	730	660	37	20
	600	840	770	37	20	845	770	41	20
	700	910	840	37	24	960	875	41	24

"n" number of holes

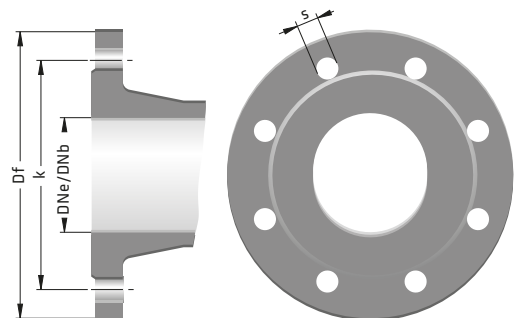



Pump • Fire Fighting Units • Booster Set

SKM

MULTISTAGE CENTRIFUGAL PUMPS



Kalasanati.com



Handled Liquids

Clean or slightly contaminated low viscosity liquids without solid & fibrous particles.

Technical Data

Discharge Flange _____ DN 32.....DN 250 mm

Capacity _____ up to 1000 m³/h

Head _____ up to 550 m

Speed _____ up to 2900 rpm

Design Temperature _____ 10°C up to +140 °C*

Casing Pressure (Pmax) _____ 30 bar (63 bar)*

(Pmax: Suction Pressure + Shut off Head)

(*) The Material of pumps differ according to the type of pumped liquid, operating temperature and pressure. Contact for detailed information.

Design Features

- Horizontal ring section, multistage, centrifugal pumps with closed impeller and diffuser.
- 10 Models from DN 32 up to 250 discharge flange diameter.
- Suction nozzle flanges conform to EN 1092 - 2 / PN 16 and discharge nozzle flanges conform to EN 1092 - 2 / PN 40 (PN 63) (For steel or stainless steel casing pumps, flanges conform to related pressure class ratings defined in EN 1092 - 1)

- In standard production, suction flange is placed on the right side and close to the coupling while discharge flange is at the other end and radially upwards (R 3/0). If other flange position is required, it should be indicated in the order.
- All impellers are balanced dynamically or statically according to ISO 1940 class 6.3.
- Axial thrust is balanced by impeller balancing holes system.
- Direction of rotation is clockwise viewed from drive end.
- Bearings of SKM type pumps are always grease lubricated.

Shaft Sealing

- In standard production soft packing application is applied up to 110 °C. Between 110 °C and 140 °C soft packing may also applied together with the stuffing box cooling.
- Pumps with mechanical seal can also be manufactured upon request.

Pump Designation

SKM - K 100 / 6

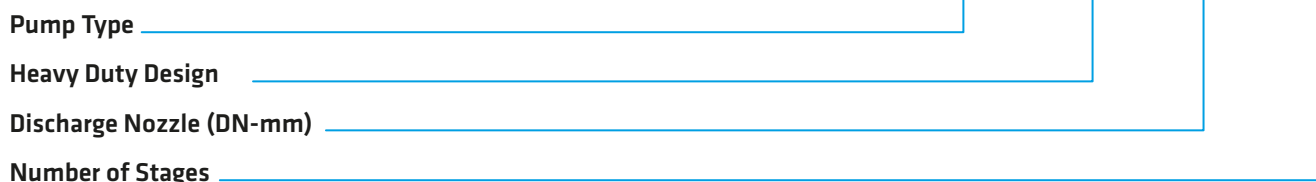

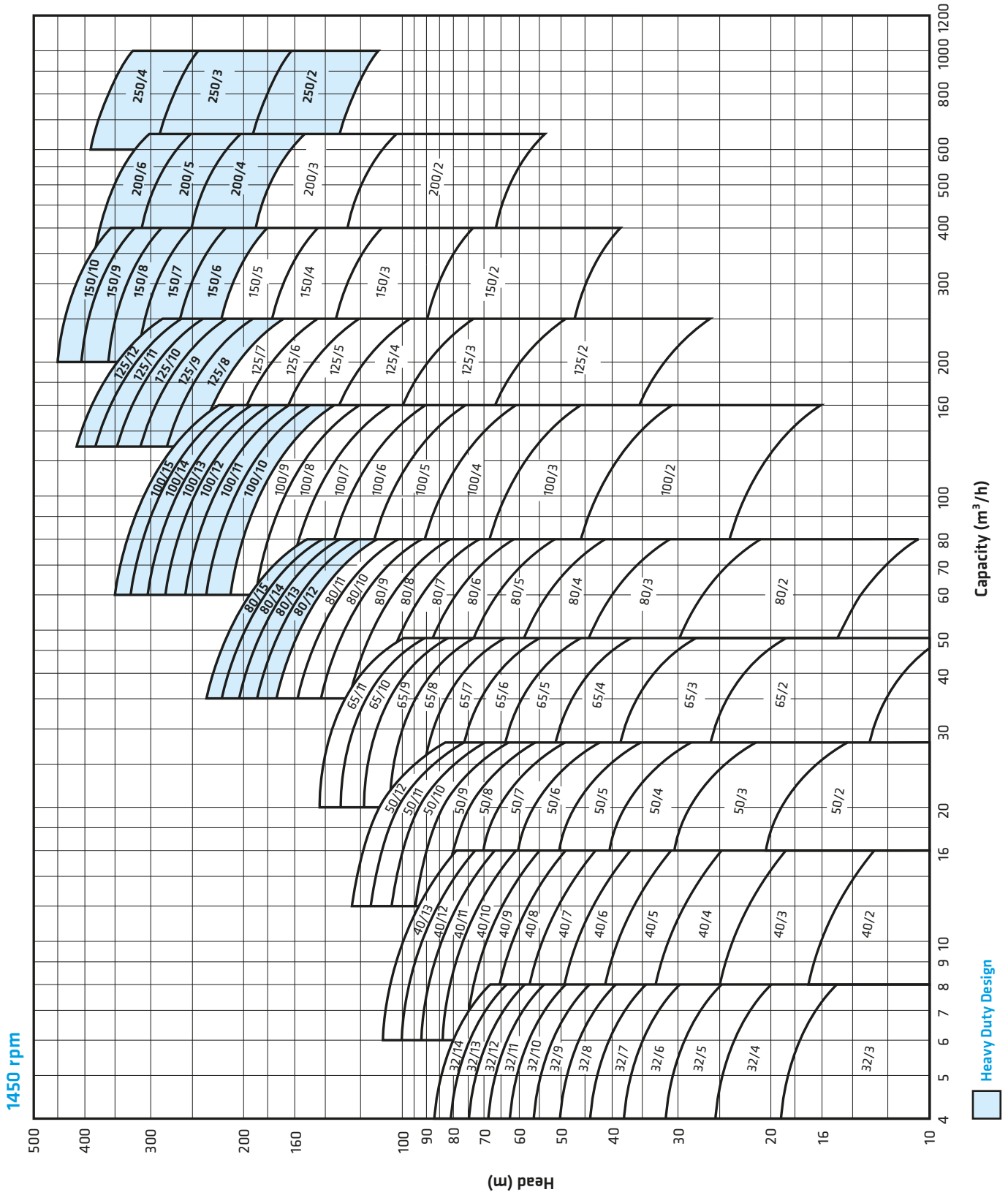

Field Chart



Narrow Impellers

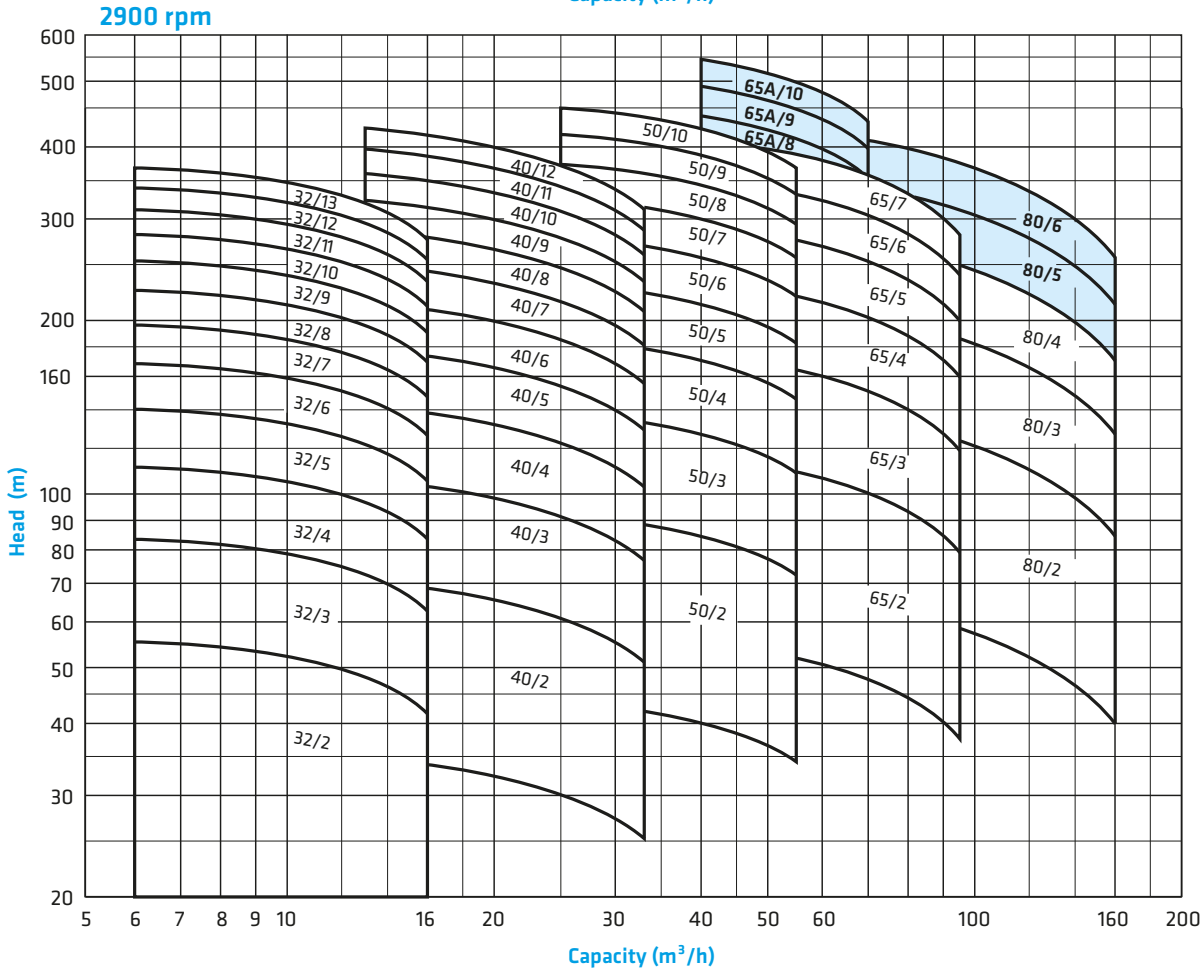
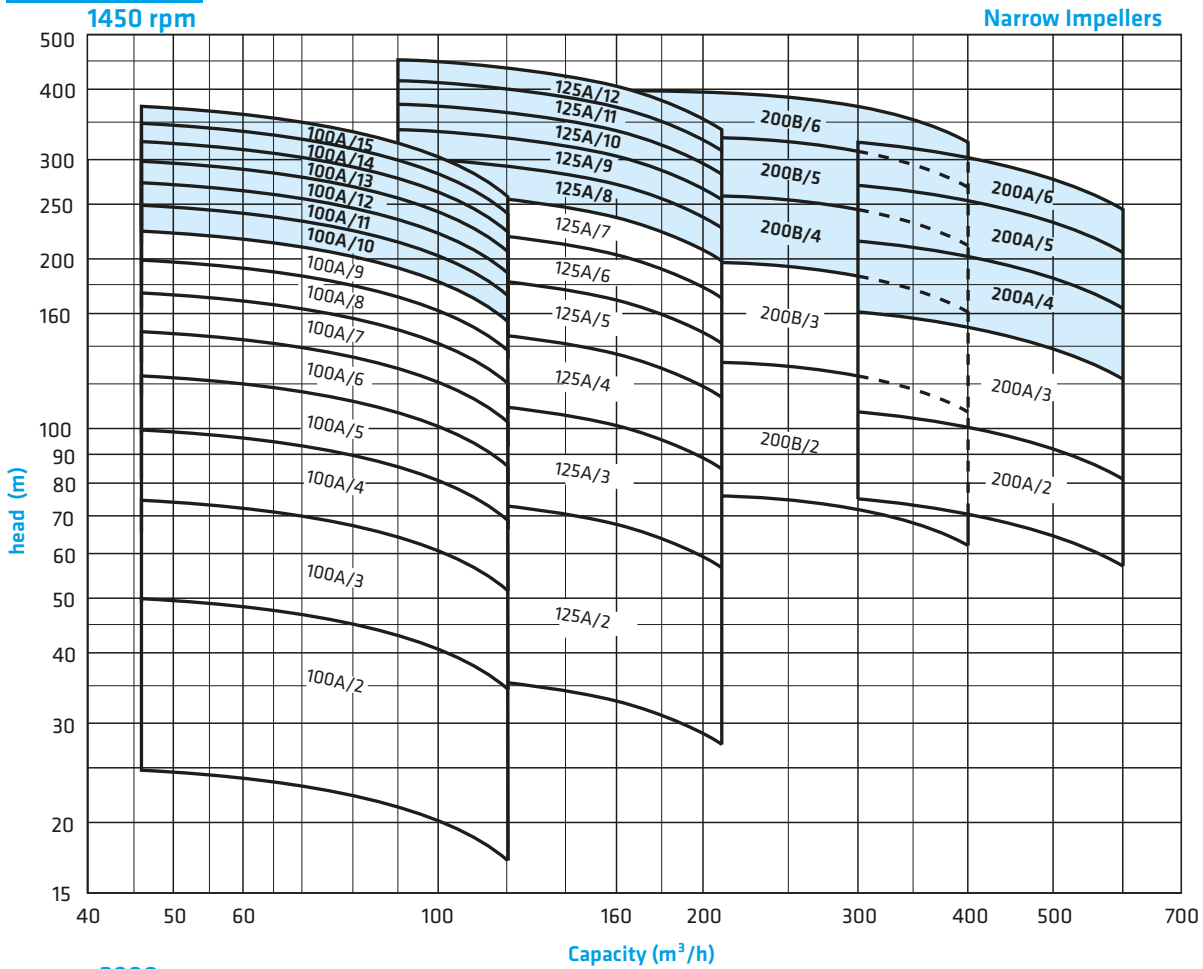

Heavy Duty Design



Kalasanati.com

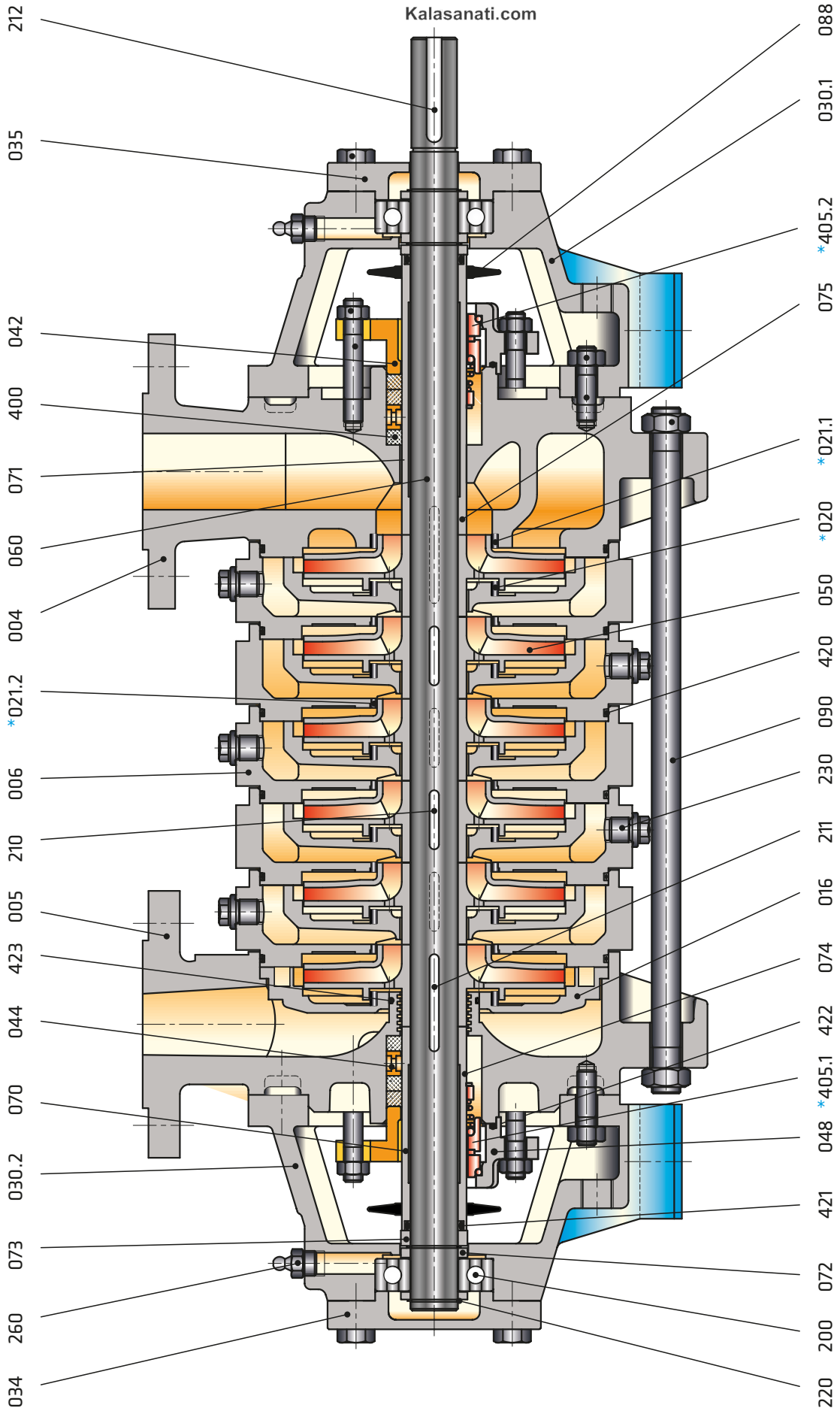

Sectional Drawings

SKM - 80 - 100 - 125 - 150 - 200 - 250 Series

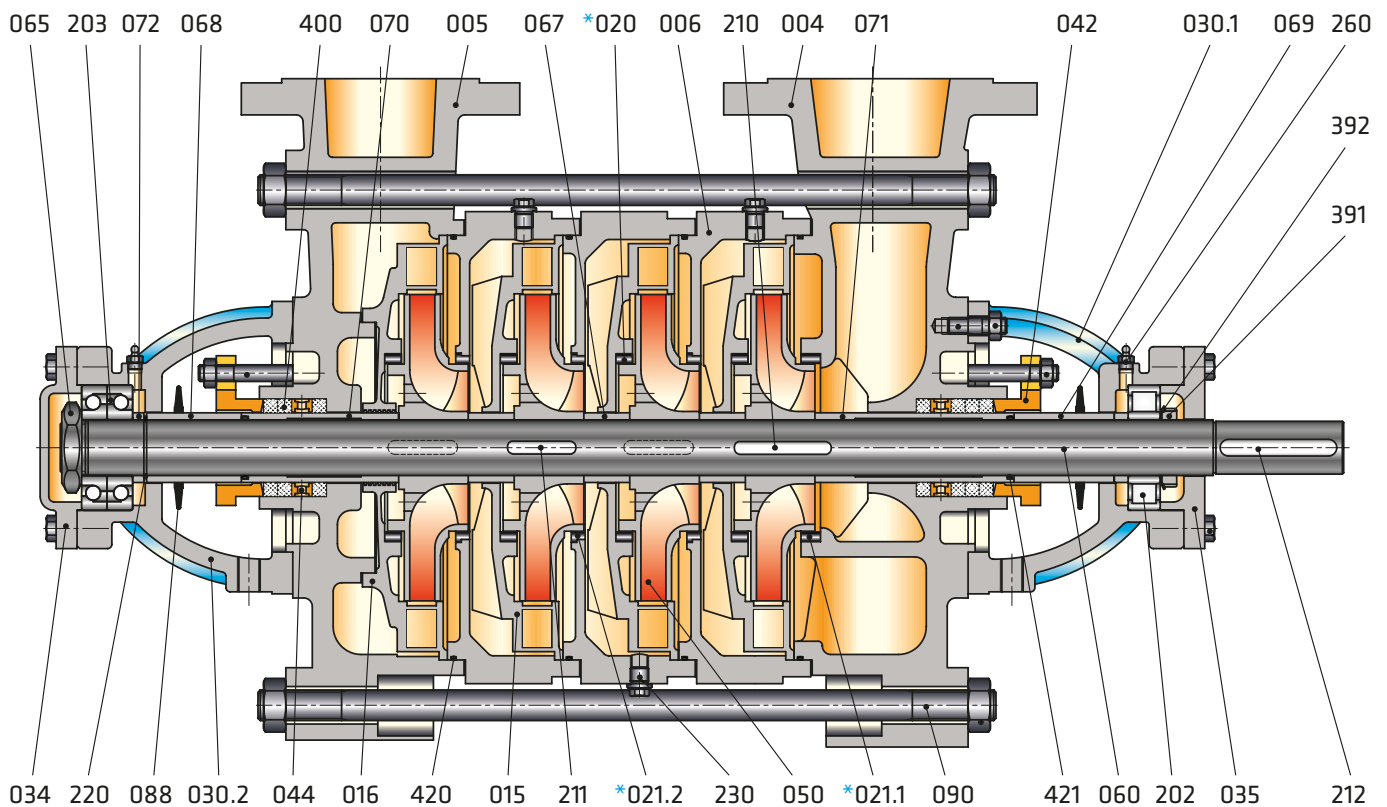

Part List

004	Suction Casing	072	Spacer Sleeve (discharge side)
005	Discharge Casing	073	Spacer Sleeve
006	Stage Casing	074	Mechanical Seal Sleeve (discharge)
015	Diffuser	075	Mechanical Seal Sleeve (suction)
016	Final Stage Diffuser	088	Thrower
*020	Wear Ring (stage casing)	090	Casing Tiebolt
*021.1	Wear Ring (suction casing)	200	Ball Bearing
*021.2	Wear Ring (stage casing)	202	Cylindrical Roller Bearing
030.1	Bearing Housing (suction casing)	203	Angular Contact Ball Bearing
030.2	Bearing Housing (discharge casing)	210	Impeller Key
034	Bearing End Cover	211	Stage Key
035	Bearing Cover (coupling side)	212	Coupling Key
042	Stuffing Box Gland	220	Retaining Ring
044	Lantern Ring	230	Drain Plug
048	Mechanical Seal Cover	260	Grease Nipple
050	Impeller	391	Shaft Nut
060	Shaft	392	Lock Washer
065	Shaft Nut	400	Stuffing Box Packing
067	Interstage Sleeve	*405.1	Mechanical Seal (Discharge)
068	Spacer Sleeve (discharge side)	*405.2	Mechanical Seal (Suction)
069	Spacer Sleeve (suction side)	420	O-Ring (stage casing)
070	Shaft Protecting Sleeve (discharge side)	421	O-Ring (shaft protecting sleeve)
071	Shaft Protecting Sleeve (suction side)	422	O-Ring (mechanical seal cover)
		423	O-Ring (discharge casing)

(*) Optional

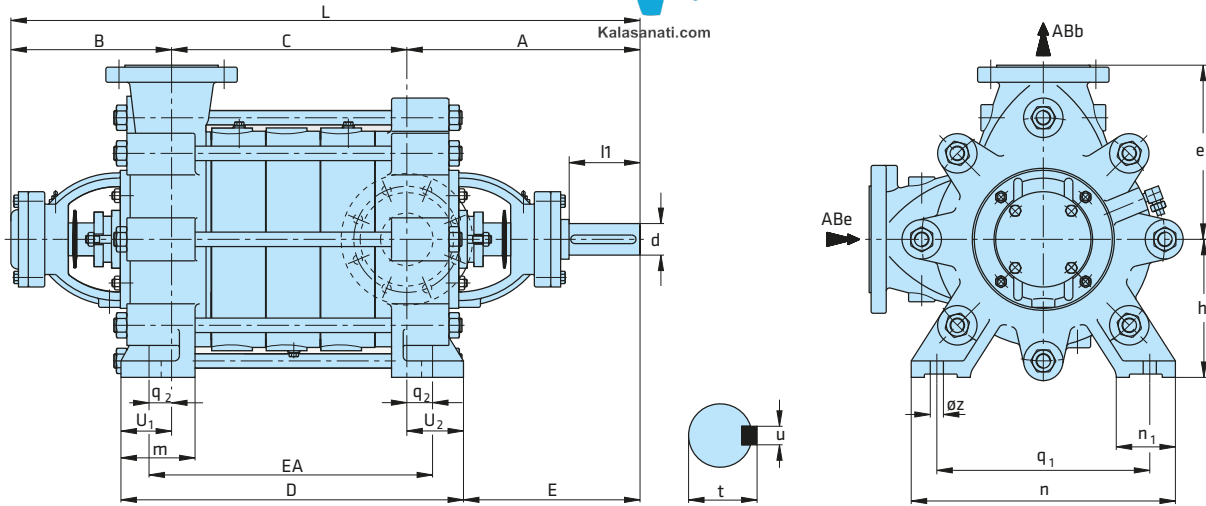

“C” according to the number of stages (mm)

Pump Type	1	2	3	4	5	6	7	8	9	10	11	12	13	14	15
32	71	114	157	200	243	286	329	372	415	458	501	544	587	630	
40	78	133	188	243	298	353	408	463	518	573	628	683	738		
50	90	152	214	276	338	400	462	524	586	648	710	772			
65	107	178	249	320	391	462	533	604	675	746	817				
80	112	195	278	361	444	527	610	693	776	859	942	1025	1108	1191	1274
100	133	233	333	433	533	633	733	833	933	1033	1133	1233	1333	1433	1533
125	165	280	395	510	625	740	855	970	1085	1200	1315	1430			
150	218	363	508	653	798	943	1088	1233	1378	1523					
200	267	437	607	777	947	1117									
250		520	722	924											

Pump Type	Dimensions (mm)																	
	ABe	ABb	A	B	EA	D	L	E	e	h	m	n	n1	q1	q2	øz	u1	u2
32	40	32	241	165	C+170	C+205	C+406	145	152	132	60	192	55	136	85	15	98,5	106,5
40	50	40	238	165	C+173	C+219	C+403	134	175	160	60	232	55	175	86,5	15	109,5	109,5
50	65	50	254	175	C+183	C+230	C+429	145	190	160	60	256	60	200	91,5	15	117	113
65	80	65	271	195	C+190	C+234	C+466	150	215	180	60	294	60	240	95	15	124	120
80	100	80	321	250	C+84	C+124	C+571	259	265	210	85	410	90	340	42	15	62	62
100	125	100	389	285	C+104	C+140	C+674	319	300	250	90	450	90	370	48	15	70	70
125	150	125	412	300	C+110	C+124	C+712	332	375	300	105	560	105	450	55	20	83	83
150	200	150	486	360	C+130	C+208	C+846	381	425	350	130	655	110	550	65	26	103	105
200	250	200	515	385	C+138	C+210	C+900	410	500	400	130	675	120	550	65	27	105	105
250	300	250	708	444	C+148	C+260	C+1152	577	627	472	155	775	150	625	74	32	130	129

Note : All rights reserved.

 Heavy Duty Design

Flange Dimensions

EN 1092 - 2	DNe/DNb	Suction & Discharge (PN 16)				Suction & Discharge (PN 40)			
		Df	k	s	n	Df	k	s	n
	32	140	100	19	4	140	100	19	4
40	150	110	19	4	150	110	19	4	
50	165	125	19	4	165	125	19	4	
65	185	145	19	4	185	145	19	8	
80	200	160	19	8	200	160	19	8	
100	220	180	19	8	235	190	23	8	
125	250	210	19	8	270	220	28	8	
150	285	240	23	8	300	250	28	8	
200	340	295	23	12	375	320	31	12	
250	405	355	28	12	450	385	34	12	
300	460	410	28	12	515	450	34	16	

“ n “ number of holes

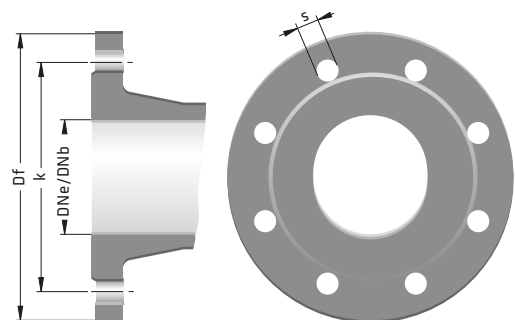

Technical Data

Standard Application

Pump Type	Shaft End				Weight (kg)	
	d1	l1	v	u	G1	g
32	24	60	27	8	44	6
40	24	60	27	8	58	9,5
50	28	65	31	8	89	13
65	32	65	35	10	92	20
80	38	80	41	10	128	26
100	42	110	45	12	177	42
125	48	110	51,5	14	330	75
150	55	110	59	16	580	120
200	70	140	74,5	20	920	200

Pump weight = G1 + (s x g) (s : number of stage)

Maximum number of stages according to shaft material

Pump Type	1.4462 / 1.4021		1.4301 / 1.4401	
	1450 rpm (1750 rpm)	2900 rpm (3500 rpm)	1450 rpm (1750 rpm)	2900 rpm (3500 rpm)
32	14(14)	13(9)	14(14)	13(8)
40	13(13)	12(8)	13(13)	7(3)
50	12(12)	10(6)	12(10)	7(2)
65	11(11)	7(4)	11(8)	5(2)
80	11(11)	4(2)	11(8)	3(N/A)
100	9(7)	-	6(4)	-
125	7(5)	-	4(2)	-
150	5(3)	-	3(N/A)	-
200	3(2)	-	3(N/A)	-

Heavy Duty Design

Pump Type	Shaft End				Weight (kg)	
	d1	l1	v	u	G1	g
65A	38	65	41	10	105	20
80	42	80	45	12	146	26
100	48	110	51,5	14	205	42
125	55	110	59	16	370	75
150	65	110	69	18	630	120
200	70	140	74,5	20	945	200
250	100	220	106	28	1250	320

Pump weight = G1 + (s x g) (s : number of stage)

Maximum number of stages according to shaft material

Pump Type	1.4462 / 1.4021		1.4301 / 1.4401	
	1450 rpm (1750 rpm)	2900 rpm (3500 rpm)	1450 rpm (1750 rpm)	2900 rpm (3500 rpm)
65A	-	10(7)	-	N/A
80	15(15)	6(3)	15(N/A)	N/A
100	15(11)	-	N/A(N/A)	-
125	12(8)	-	8(N/A)	-
150	10(6)	-	7(N/A)	-
200	6(4)	-	5(N/A)	-
250	4(3)	-	4(N/A)	-

Bearing Type

Standard Application

1450 rpm (1750 rpm)

Pump Type	Number of Stages	Bearing Type	
		Suction	Discharge
32	2...14(14)	6305	6305
40	2...13(13)	6305	6305
50	2...12(12)	6306	6306
65	2...11(11)	6307	6307
80	2...11(11)	NU 308	3308
100	2...9(7)	NU 309	3309
125	2...7(5)	NU 310	3310
150	2...5(3)	NU 312	3312
200	2...3(2)	NU 315	2x7315

2900 rpm (3500 rpm)

Pump Type	Number of Stages	Bearing Type		Number of Stages	Bearing Type	
		Suction	Discharge		Suction	Discharge
32	2...9(6)	6305	6305	10(7)...13(9)	NU 305	6405
40	2...6(4)	6305	6305	7(5)...12(8)	NU 305	6405
50	2...5(3)	6306	6306	6(4)...10(6)	NU 306	6406
65	2...4(2)	6307	6307	5(3)...7(4)	NU 307	6407
80	-	-	-	2(2)...4(2)	NU 308	3308

Heavy Duty Design

1450 rpm (1750 rpm)

Pump Type	Number of Stages	Bearing Type	
		Suction	Discharge
80	11(11)...15(15)	NU 309	2 x 7309
100	9(9)...15(11)	NU 310	2 x 7310
125	7(7)...12(8)	NU 312	2 x 7312
150	5(5)...10(6)	NU 314	2 x 7314
200	3(3)...6(4)	NU 316	2 x 7316
250	2(2)...4(3)	NU 321	2 x 7321

2900 rpm (3500 rpm)

Pump Type	Number of Stages	Bearing Type	
		Suction	Discharge
65A	8(N/A)...10(N/A)	NU 308	2 x 7308
80	5(N/A)...6(N/A)	NU 309	2 x 7309



Kalasanati.com

SKM

Technical Data

PART LIST	0.6025	0.7040	0.7043	1.0619	1.4308	1.4309	1.4408	1.4409	1.4500	1.4517	1.4469	1.4317	1.4008	2.1050.01	2.0975.01	2.1096.01	1.0503	1.4021	1.4021+QT	1.4301	1.4404	1.4460	1.4462	
Suction Casing	●	○	○		○	○	○	○	○	○	○	○	○	○										
Discharge Casing	●	○	○		○	○	○	○	○	○	○	○	○	○										
Stage Casing	●	○	○		○	○	○	○	○	○	○	○	○	○										
Diffuser	●	○	○	○	○	○	○	○	○	○	○	○	○	○	○	○								
Impeller	●	○	○	○	○	○	○	○	○	○	○	○	○	○	○	○							○	
Shaft																		●	○	○	○			○
Bearing Housing	●	○	○	○	○	○	○	○																
Wear Ring	○	○	○	○	○	○	○	○	○	○	○	○	○	○	○	○								
Spacer Sleeve																		●	○	○	○	○		○
Shaft Protecting Sleeve																		●	○	○	○	○		○
Interstage Sleeve																		●	○	○	○	○		○
Mechanical Seal (*)	EN 12756																							

(*) Optional : Depending on customer requirement or request different types and brands of mechanical seals are applicable.

● Standard manufacturing
○ Optional

Material Equivalents

Description	DIN / EN	AISI / SAE / ASTM	
Cast Iron	0.6025	EN-GJL-250 (GG25)	A48 Class 40B
Nodular Cast Iron	0.7040	EN-GJS-400-15 (GGG40)	A536 60-40-18
Nodular Cast Iron	0.7043	EN-GJS-400-18-LT (GGG40.3)	A536 60-40-18
Cast Steel	1.0619	GP240GHGS-C25	A216 WCB
Chrome Nickel Cast Steel	1.4308	GX5CrNi19-10	A351 CF8
Chrome Nickel Cast Steel (low carbon)	1.4309	GX2CrNi19-11	A351 CF3
Chrome Nickel Molybdenum Cast Steel	1.4408	GX5CrNiMo19-11-2	A351 CF8M
Chrome Nickel Molybdenum Cast Steel (low carbon)	1.4409	GX2CrNiMo19-11-2	A351 CF3M
Austenitic Cast Steel	1.4500	GX7NiCrMoCuNb25-20	A351 CN7M
Austenitic - Ferritic Cast Steel (duplex)	1.4517	GX2CrNiMoCuN25-6-3-3	A890 CD4MCuN
Austenitic - Ferritic Cast Steel (super duplex)	1.4469	GX2CrNiMoN26-7-4	A890 CE3MN
Martenzitic Stainless Cast Steel	1.4317	GX4CrNi13-4	A352 CA6NM
Martenzitic Stainless Cast Steel	1.4008	GX7CrNiMo12-1	A217 CA15
Cast Bronze (tin alloy)	2.1050.01	G-CuSn10	B427 C90700
Cast Bronze (nickel alloy)	2.0975.01	G-CuAl10Ni	B148 C95500
Cast Bronze (lead)	2.1096.01	G-CuSn5ZnPb	B584 C83600
Carbon Steel	1.0503	C45	AISI 1045
Chrome Steel	1.4021	X20Cr13	A276 Type 420
Chrome Steel (heat treated)	1.4021	X20Cr13	A276 Type 420+QT
Chrome Nickel Steel	1.4301	X5CrNi18-10	A276 Type 304
Chrome Nickel Steel (low carbon)	1.4404	X2CrNiMo17-12-2	A276 Type 316L
Duplex (austenitic-ferritic) Steel	1.4460	X3CrNiMoN27-5-2	AISI 329
Duplex (austenitic-ferritic) Steel	1.4462	X2CrNiMoN22-5-3	UNS S32205

Flange Positions

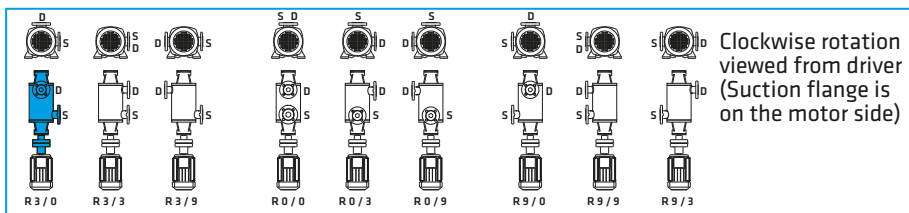

R 3/0

— Discharge Flange Position (D)
— Suction Flange Position (S)
— Direction of Rotation (R/L)

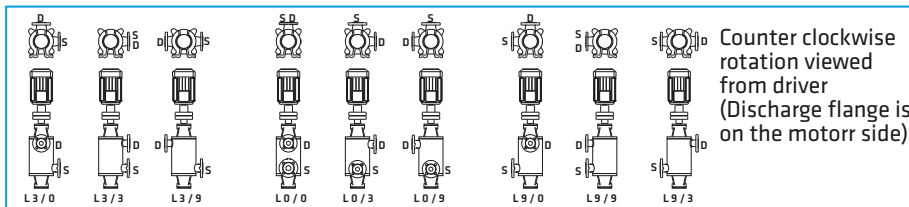

Direction of rotation viewed from driver end
R : Right
L : Left



Pump • Fire Fighting Units • Booster Set

SKM-E MULTISTAGE PUMPS (END SUCTION)



Handled Liquids

Clean or slightly contaminated low viscosity liquids without solid & fibrous particles.

Technical Data

Discharge Flange _____ DN 40....DN 150 mm

Capacity _____ up to 400 m³/h

Head _____ up to 450 m

Speed _____ up to 2900 rpm

Design Temperature _____ -10°C up to +140 °C*

Casing Pressure (Pmax) _____ 30 bar (63 bar)*

(Pmax: Suction Pressure + Shut off Head)

(*) The Material of pumps differ according to the type of pumped liquid, operating temperature and pressure. Contact for detailed information.

Design Features

- Horizontal ring section, multistage, centrifugal pumps with closed impellers and diffusers in end suction design.
- 7 Models from DN 40 up to DN 150 discharge flange diameter.
- Suction nozzle flanges conform to EN 1092 - 2 / PN 16 and discharge nozzle flanges conform to EN 1092 - 2 / PN 40 (PN 63) (For steel or stainless steel casing pumps, flanges conform to related pressure class ratings defined in EN 1092 - 1)

Pump Designation

Pump Type _____

Discharge Nozzle (DN-mm) _____

Number of Stages _____

SKM-E 100 / 6

- Discharge flange is on top for standard production, upon request different discharge flange positions can be applied.
- All impellers are balanced dynamically or statically according to ISO 1940 class 6.3.
- Axial thrust is balanced by impeller balancing holes system.
- Direction of rotation is always counter clockwise viewed from drive end. That's why these pumps can not be accoupled directly with diesel engines.
- Bearings of SKM-E type pumps are grease lubricated. Journal bearing used in the suction side is lubricated by the pumping liquid.

Shaft Sealing

- In standard production soft packing application is applied up to 110 °C. Between 110 °C and 140 °C soft packing may also applied together with the stuffing box cooling.
- Pumps with mechanical seal can also be manufactured upon request.

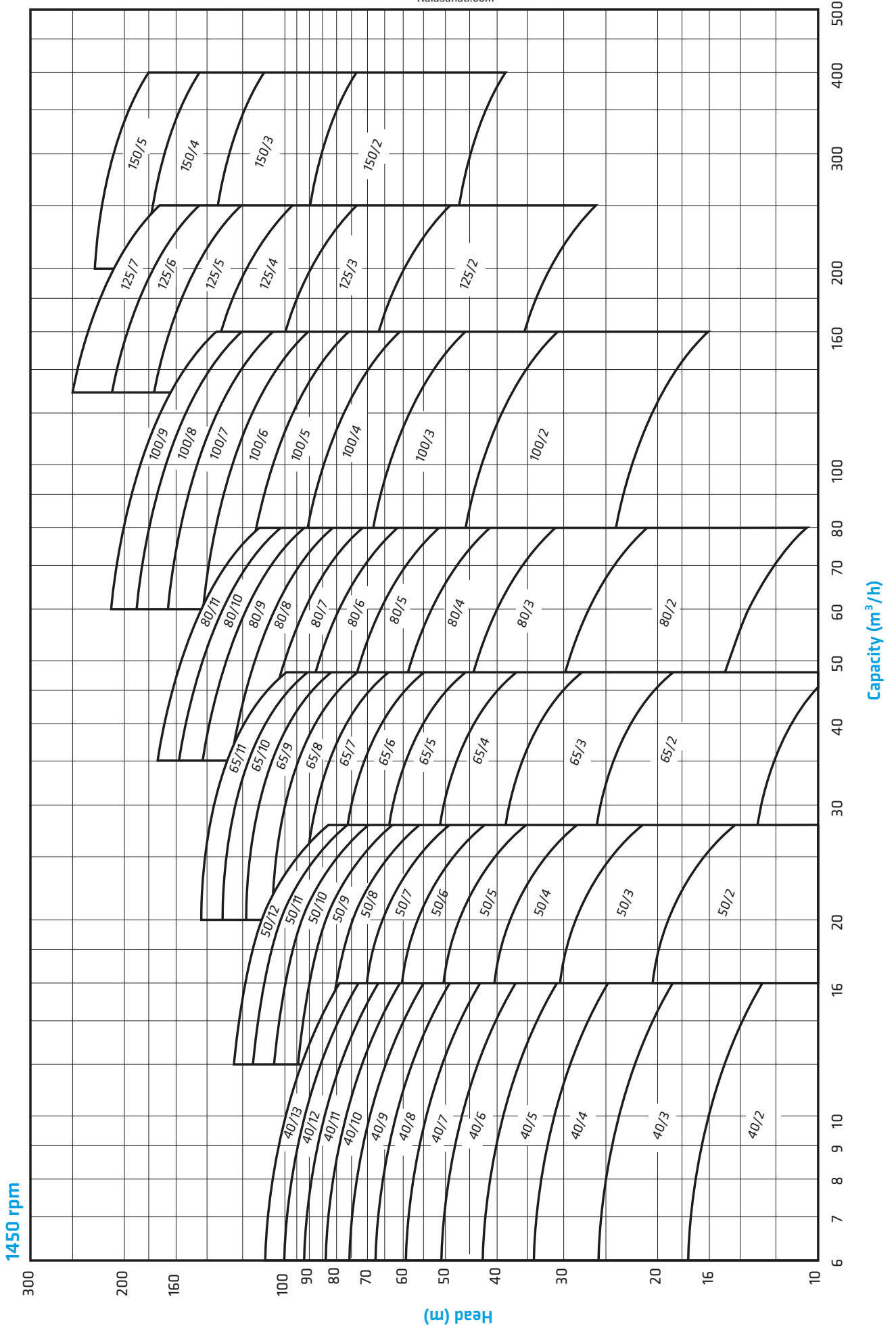

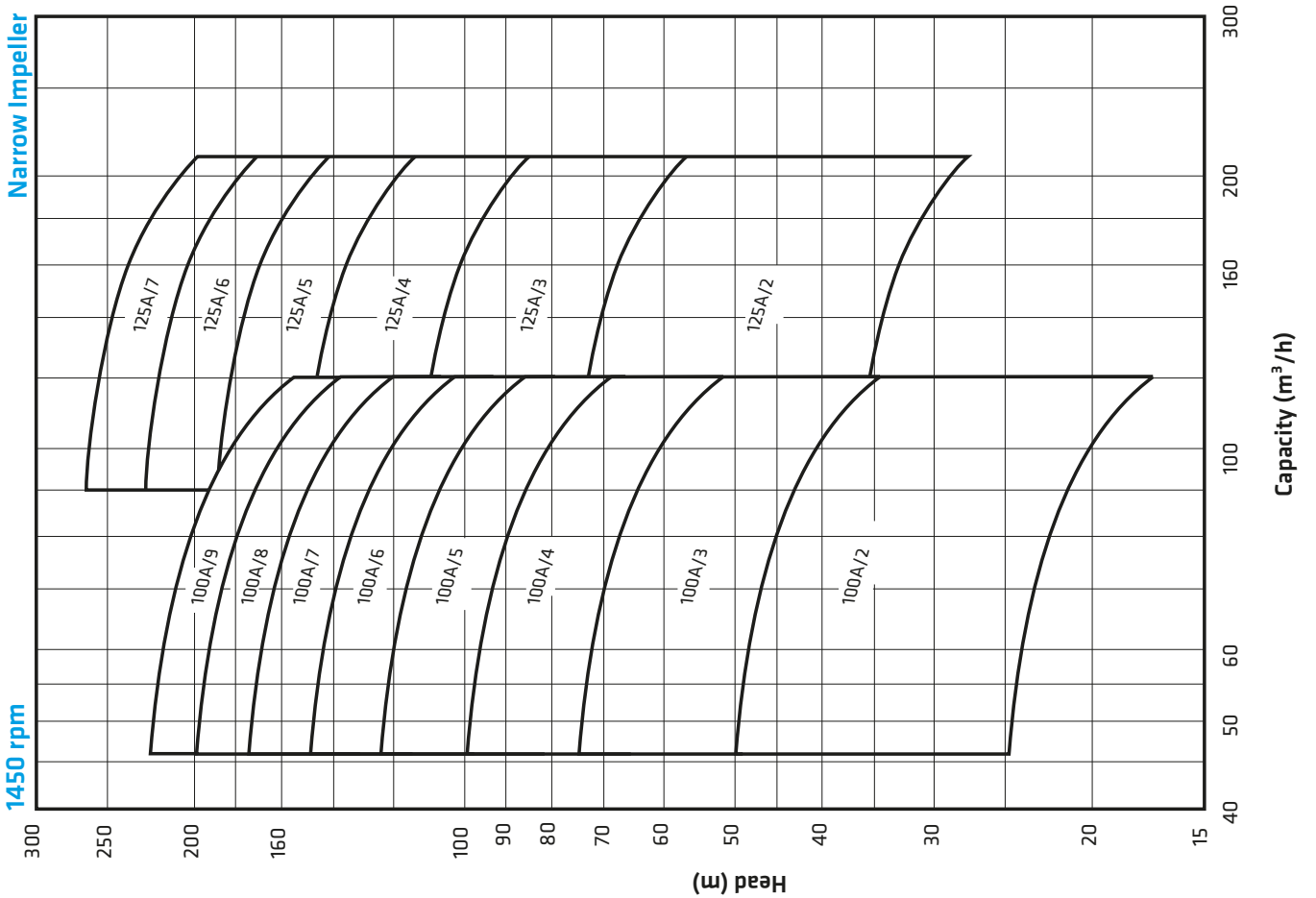
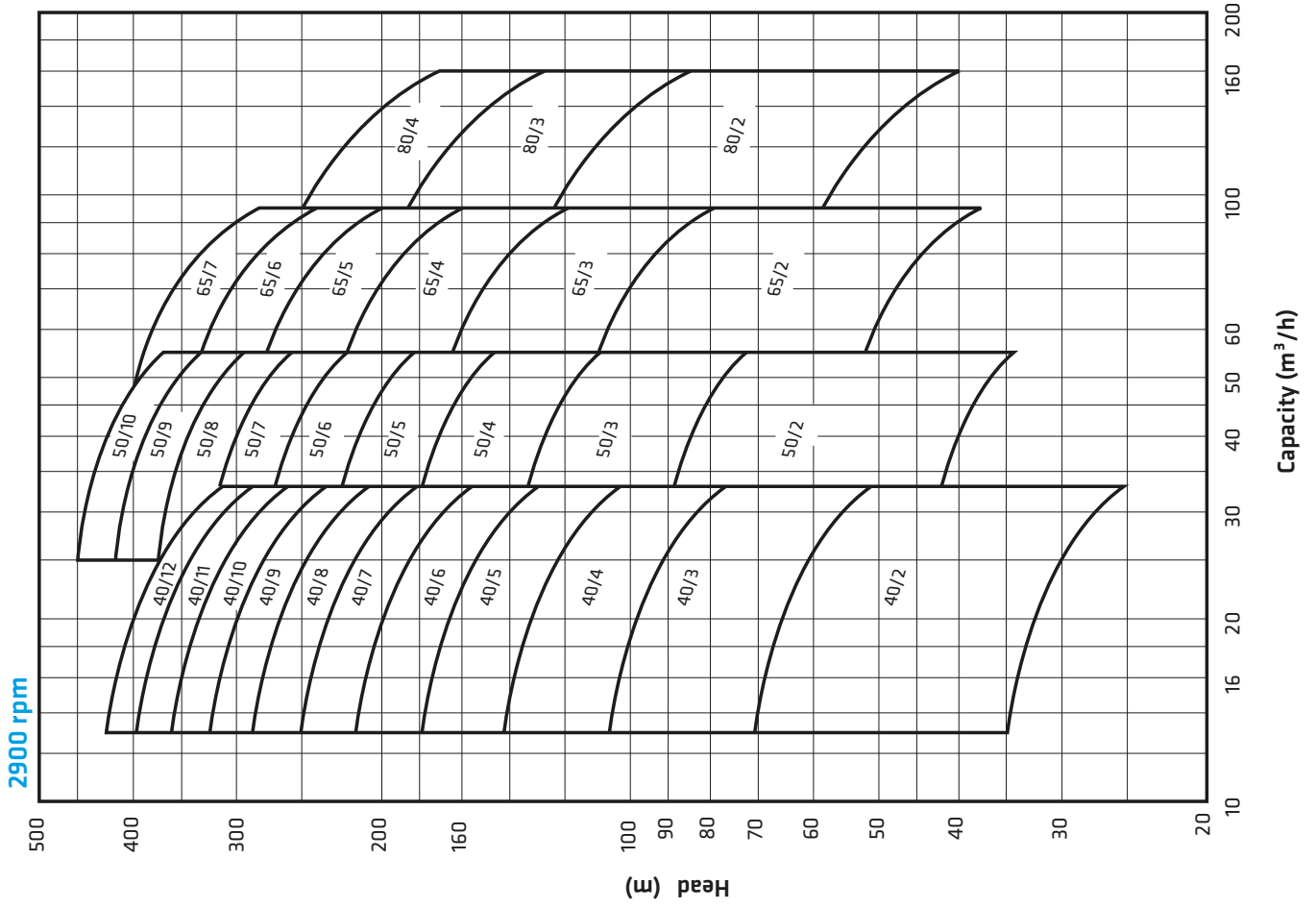

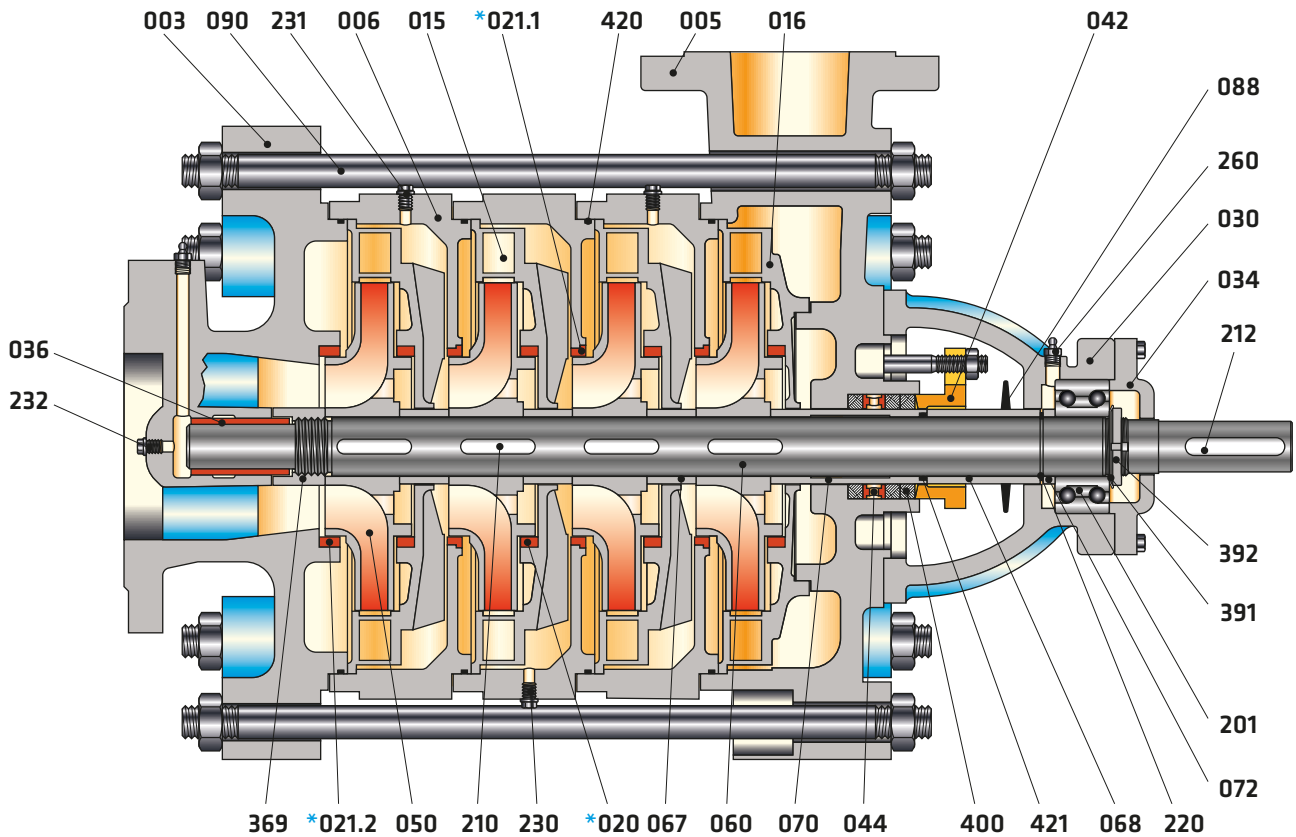

Part List

003	Suction Casing	*074	Shaft Sleeve (mechanical seal)
005	Discharge Casing	088	Thrower
006	Stage Casing	090	Tiebolt
015	Diffuser	201	Double Row Ball Bearing
016	Last Stage Diffuser	210	Impeller Key
*020	Wear Ring (diffuser)	212	Coupling Key
*021.1	Wear Ring (stage casing)	220	Retaining Ring
*021.2	Wear Ring (suction casing)	230	Drain Plug
030	Bearing Housing	231	Filling Plug
034	Bearing Cover	232	Plug
036	Sleeve Bearing	260	Grease Nipple
042	Stuffing Box Gland	369	Shaft Nut
044	Lantern Ring	391	Lock Washer
*048	Mechanical Seal Cover	392	Shaft Nut
050	Impeller	400	Soft Packing
060	Shaft	*405	Mechanical Seal
067	Interstage Sleeve	420	O-Ring
068	Spacer Sleeve (discharge side)	421	O-Ring
070	Shaft Sleeve (soft packing)	*422	O-Ring
072	Spacer Sleeve (bearing)		

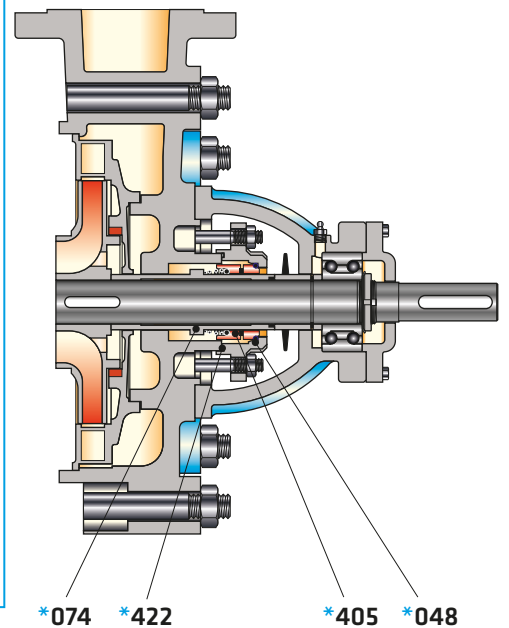

(*) Optional



Kalasanati.com

Technical Data

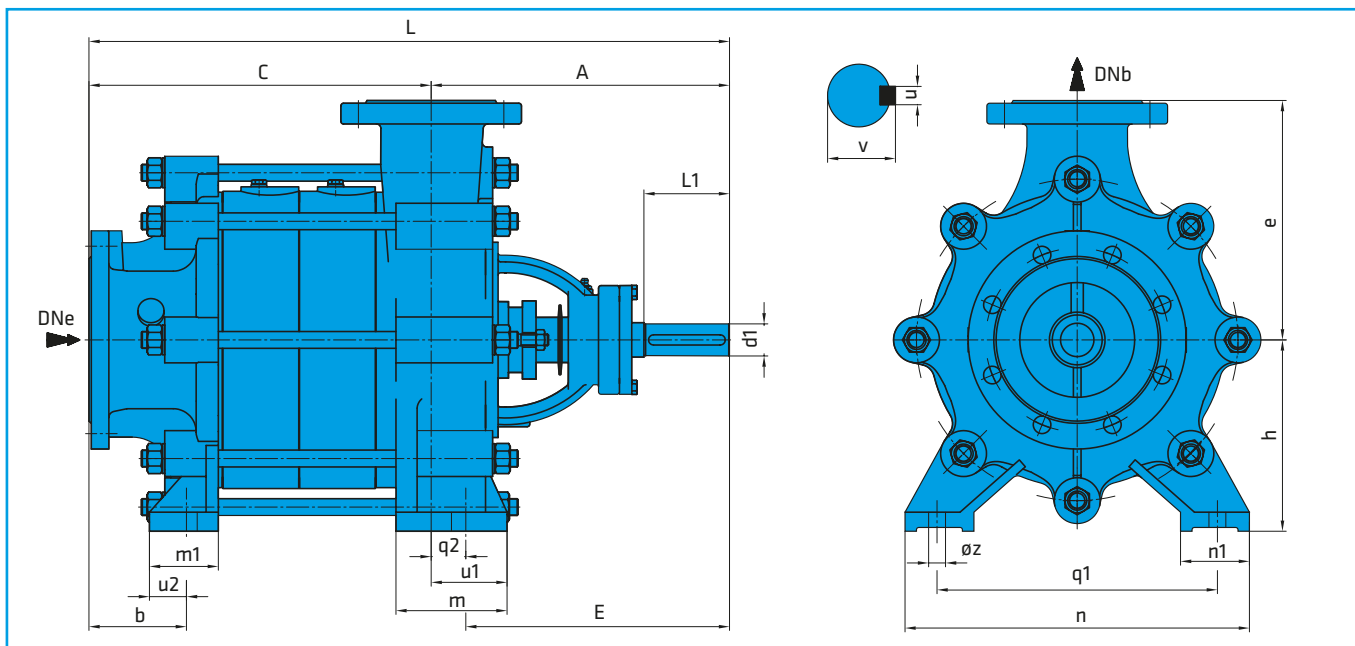

“C” according to the number of stages (mm)

Maximum number of stages according to shaft material

Bearing Type

Pump Type	2	3	4	5	6	7	8	9	10	11	12	13
40	187	242	297	352	407	462	517	572	627	682	737	792
50	212	274	336	398	460	522	584	646	708	770	832	
65	247	318	389	460	531	602	673	744	815	886		
80	280	363	446	529	612	695	778	861	944	1027		
100	347	447	547	647	747	847	947	1047				
125	364	479	594	709	824	939						
150	437	582	727	872								

Pump Type	1.4462 / 1.4021		1.4301 / 1.4401	
	1450 rpm 1750 rpm	2900 rpm 3500 rpm	1450 rpm 1750 rpm	2900 rpm 3500 rpm
40	13(13)	12(8)	13(13)	7(3)
50	12(12)	10(6)	12(10)	7(2)
65	11(11)	7(4)	11(8)	5(2)
80	11(11)	4(2)	11(8)	3(N/A)
100	9(7)	-	6(4)	-
125	7(5)	-	4(2)	-
150	5(3)	-	3(N/A)	-

Pump Type	Bearing Type
40	6305
50	6306
65	6307
80	3308
100	3309
125	3310
150	3312

Pump Type	Dimensions (mm)																	Shaft				Weight (kg)	
	DNe	DNb	A	b	L	E	e	h	m	m1	n	n1	q1	q2	øz	u1	u2	d1	l1	v	u	G	g
40	65	40	237	23	C+237	147	175	160	60	75	232	55	175	90	15	109	20	24	60	27	8	54	9,5
50	80	50	258	23	C+259	160	190	160	60	85	256	60	200	98	15	115	20	28	65	31	8	82	13
65	100	65	275	38	C+275	170	215	180	60	85	294	60	240	121	15	125	25	32	65	35	10	85	20
80	125	80	331	75	C+331	289	265	210	85	85	410	90	340	42	15	62	25	38	80	41	10	113	26
100	150	100	397	105	C+397	349	300	250	90	90	450	90	370	48	15	70	30	42	110	45	12	150	42
125	200	125	410	70	C+410	355	375	300	110	112	572	105	450	55	23	80	30	48	110	51,5	14	264	75
150	200	150	475	60	C+475	410	425	350	130	135	655	110	550	65	23	103	30	55	110	59	16	455	120

Note: All rights reserved.

Pump weight= G + (s x g) (s: number of stage)

Flange Dimensions

DNe/DNb	Suction & Discharge (PN 16)				Suction & Discharge (PN 40)			
	Df	k	s	n	Df	k	s	n
40	150	110	19	4	150	110	19	4
50	165	125	19	4	165	125	19	4
65	185	145	19	4	185	145	19	8
80	200	160	19	8	200	160	19	8
100	220	180	19	8	235	190	23	8
125	250	210	19	8	270	220	28	8
150	285	240	23	8	300	250	28	8
200	340	295	23	12	375	320	31	12

“ n ” number of holes

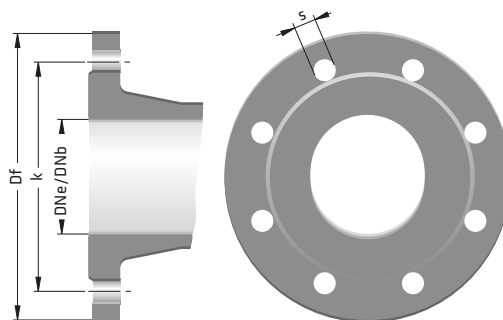



Kalasanati.com

SKM-E

Technical Data

Part List	0.6025	0.7040	0.7043	1.0619	1.4308	1.4309	1.4408	1.4409	1.4500	1.4517	1.4469	1.4317	1.4008	2.1050.01	2.0975.01	2.1096.01	1.0503	1.4021	1.4021+QT	1.4301	1.4404	1.4460	1.4462	Tungsten Carbide	
Suction Casing	●	○	○		○	○	○	○	○	○	○	○	○	○											
Discharge Casing	●	○	○		○	○	○	○	○	○	○	○	○	○											
Stage Casing	●	○	○		○	○	○	○	○	○	○	○	○	○											
Diffuser	●	○	○	○	○	○	○	○	○	○	○	○	○	○	○	○									
Impeller	●	○	○	○	○	○	○	○	○	○	○	○	○	○	○	○							○		
Shaft																		●	○	○	○			○	
Bearing Housing	●	○	○	○	○	○	○	○																	
Wear Ring	○	○	○	○	○	○	○	○	○	○	○	○	○	○	○	○									
Spacer Sleeve																	●	○	○	○	○			○	
Shaft Sleeve																	●	○	○	○	○			○	
Interstage Sleeve																	●	○	○	○	○			○	
Sleeve Bearing														●											○
Mechanical Seal (*)	EN 12756																								

(*) Optional : Depending on customer requirement or request different types and brands of mechanical seals are applicable.

● Standard manufacturing
○ Optional

Material Equivalent

Description	DIN / EN		AISI / SAE / ASTM
Cast Iron	0.6025	EN-GJL-250 (GG25)	A48 Class 40B
Nodular Cast Iron	0.7040	EN-GJS-400-15 (GGG40)	A536 60-40-18
Nodular Cast Iron	0.7043	EN-GJS-400-18-LT (GGG40.3)	A536 60-40-18
Cast Steel	1.0619	GP240GHGS-C25	A216 WCB
Chrome Nickel Cast Steel	1.4308	GX5CrNi19-10	A351 CF8
Chrome Nickel Cast Steel (low carbon)	1.4309	GX2CrNi19-11	A351 CF3
Chrome Nickel Molybdenum Cast Steel	1.4408	GX5CrNiMo19-11-2	A351 CF8M
Chrome Nickel Molybdenum Cast Steel (low carbon)	1.4409	GX2CrNiMo19-11-2	A351 CF3M
Austenitic Cast Steel	1.4500	GX7NiCrMoCuNb25-20	A351 CN7M
Austenitic - Ferritic Cast Steel (duplex)	1.4517	GX2CrNiMoCuN25-6-3-3	A890 CD4MCuN
Austenitic - Ferritic Cast Steel (super duplex)	1.4469	GX2CrNiMoN26-7-4	A890 CE3MN
Martenzitic Stainless Cast Steel	1.4317	GX4CrNi13-4	A352 CA6NM
Martenzitic Stainless Cast Steel	1.4008	GX7CrNiMo12-1	A217 CA15
Cast Bronze (tin alloy)	2.1050.01	G-CuSn10	B427 C90700
Cast Bronze (nickel alloy)	2.0975.01	G-CuAl10Ni	B148 C95500
Cast Bronze (lead)	2.1096.01	G-CuSn5ZnPb	B584 C83600
Carbon Steel	1.0503	C45	AISI 1045
Chrome Steel	1.4021	X20Cr13	A276 Type 420
Chrome Steel (heat treated)	1.4021	X20Cr13	A276 Type 420+QT
Chrome Nickel Steel	1.4301	X5CrNi18-10	A276 Type 304
Chrome Nickel Steel (low carbon)	1.4404	X2CrNiMo17-12-2	A276 Type 316L
Duplex (austenitic-ferritic) Steel	1.4460	X3CrNiMoN27-5-2	AISI 329
Duplex (austenitic-ferritic) Steel	1.4462	X2CrNiMoN22-5-3	UNS S32205

Flange Positions

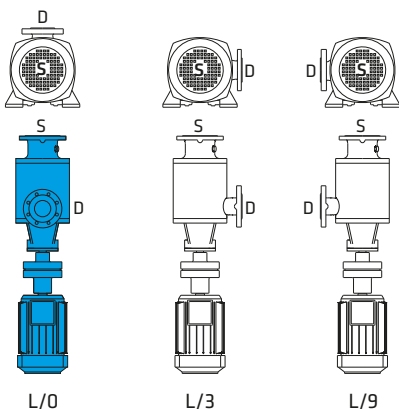

Direction of rotation is counter clockwise viewed from driver end.
(Discharge flange is on motor side)

Explanation :

L/O

Discharge Flange (D)
Direction of Rotation (L)

Viewed from drive end.

L: Left



Pump • Fire Fighting Units • Booster Set

SKMV-H

MULTISTAGE PUMPS (VERTICAL)



Kalasanati.com



Handled Liquids

Clean or slightly contaminated low viscosity liquids without solid & fibrous particles.

Technical Data

Discharge Flange _____ DN 32...DN 150 mm

Capacity _____ up to 400 m³/h

Head _____ up to 450 m

Speed _____ up to 2900 rpm

Operating Temperature _____ -10°C up to +140 °C*

Casing Pressure (Pmax) _____ 30 bar (63 bar)*

(Pmax: Suction Pressure + Shut off Head)

(*) The Material of pumps differ according to the type of pumped liquid, operating temperature and pressure. Contact for detailed information.

Design Features

- Vertical ring section, multistage, centrifugal pumps with closed impellers and diffusers.
- 8 models from DN 32 up to DN 150 discharge flange diameter.
- Suction nozzle flanges conform to EN 1092 - 2 / PN 16 and discharge nozzle flanges conform to EN 1092 - 2 / PN 40 (PN 63) (For steel or stainless steel casing pumps, flanges conform to related pressure class ratings defined in EN 1092 - 1)
- SKMV-H pumps are short coupled with electric motors of IEC frame sizes with high efficiency class.

Pump Designation

Pump Type _____

Discharge Nozzle (DN-mm) _____

Number of Stage _____

- Pump and motor shafts are connected to each other with flexible coupling.
- All impellers are balanced dynamically or statically according to ISO 1940 class 6.3.
- Axial thrust is balanced by impeller balancing holes system.
- Direction of rotation is always counter clockwise viewed from drive end.
- Bearings of SKMV-H type pumps are grease lubricated. Journal bearings used in the suction side is lubricated by the pumping liquid.

Shaft Sealing

- Depending on request or requirement, pumps with soft packing or mechanical seals can be supplied.

SKMV-H 100 / 6

02.2020 / Rev. 3



Kalasanati.com

1450 rpm

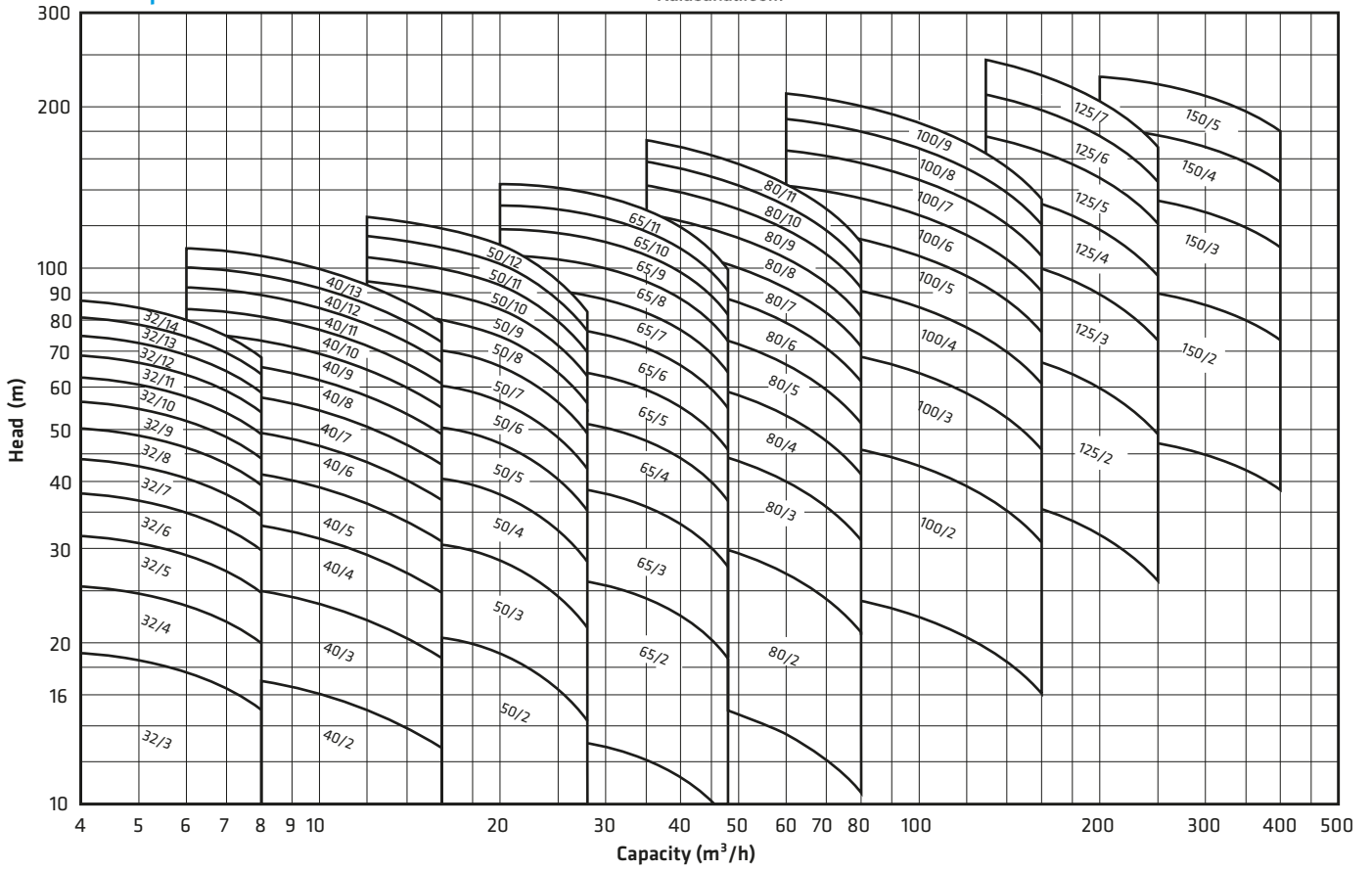

2900 rpm

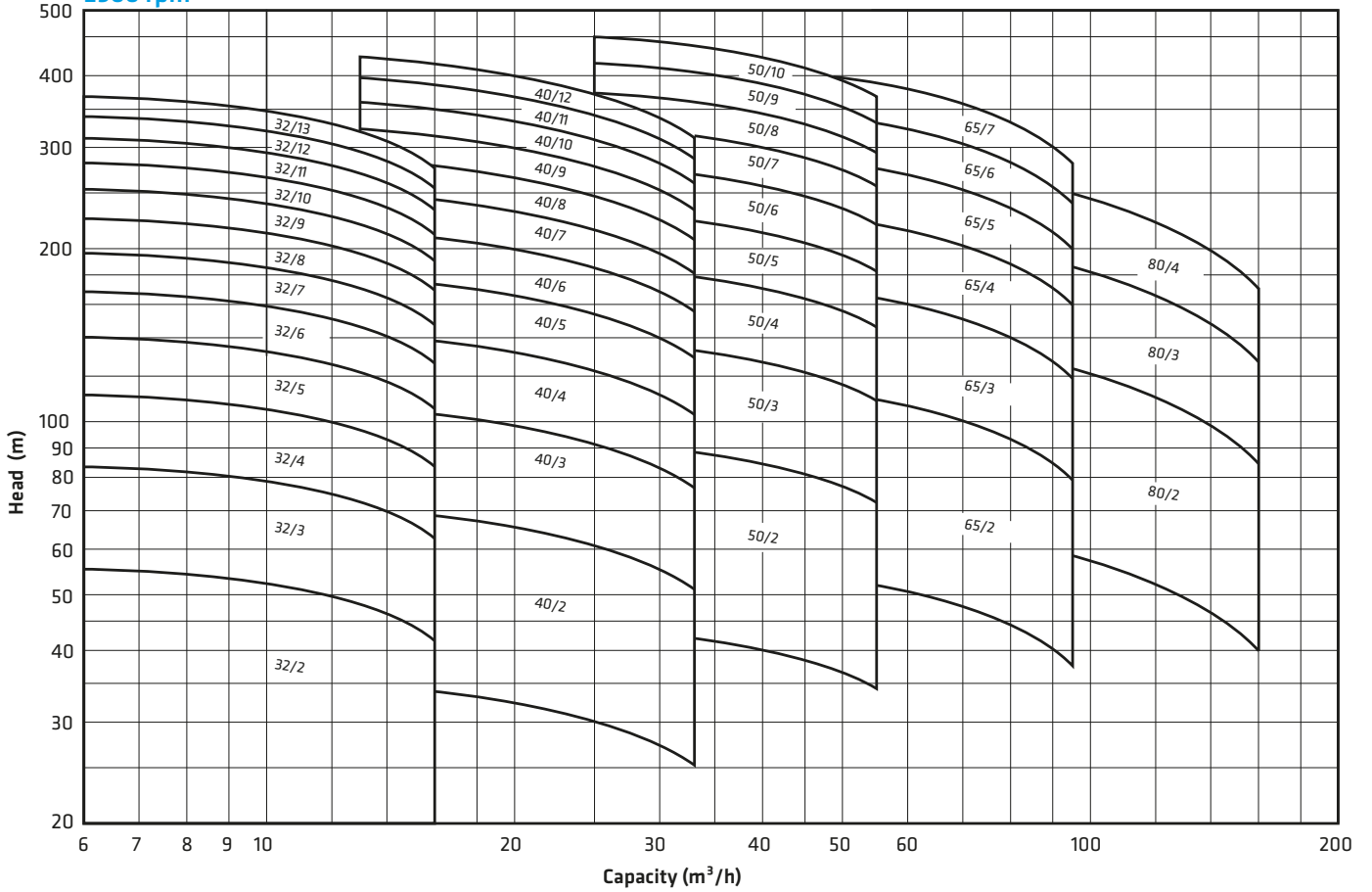

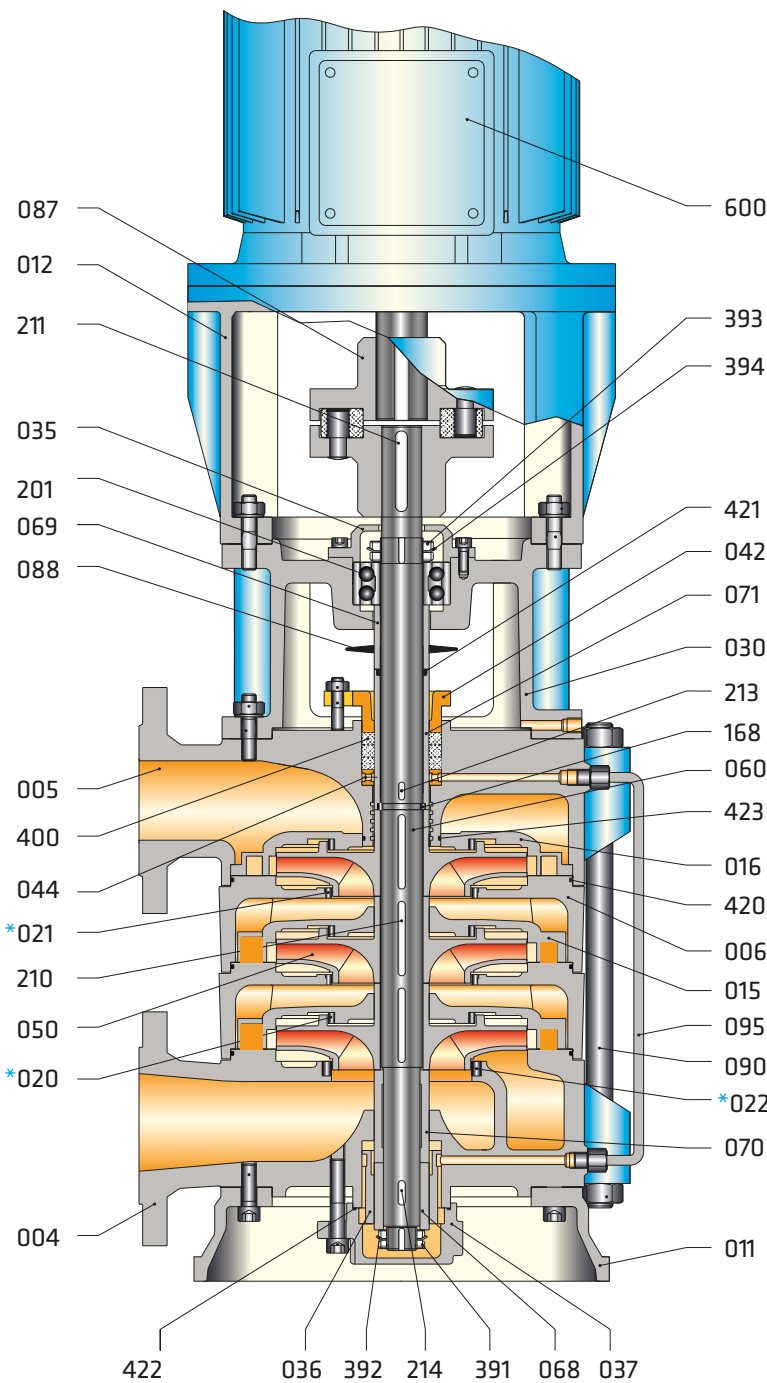

Part List

004	Suction Casing
005	Discharge Casing
006	Stage Casing
011	Pump Foot
012	Motor Pedestal
015	Diffuser
016	Last Stage Diffuser
*020	Wear Ring (diffuser)
*021	Wear Ring (stage casing)
*022	Wear Ring (suction casing)
030	Bearing Housing
035	Bearing Cover
036	Sleeve Bearing
037	Sleeve Bearing Cover
042	Gland
044	Lantern Ring
*048	Mechanical Seal Cover
050	Impeller
060	Pump Shaft
068	Shaft Sleeve (sleeve bearing)
069	Spacer Sleeve (bearing)
070	Shaft Sleeve (suction casing)
071	Shaft Protecting Sleeve (soft packing)
*074	Shaft Protecting Sleeve (mechanical seal)
087	Flexible Coupling
088	Thrower
090	Tiebolt
095	Sleeve Bearing Flushing Pipe
168	Split Ring
201	Double Row Ball Bearing
210	Key (impeller)
211	Key (coupling)
213	Key (shaft protecting sleeve)
214	Key (sleeve bearing)
391	Shaft End Nut
392	Lock Washer
393	Shaft End Nut
394	Lock Washer
400	Soft Packing
*405	Mechanical Seal
420	O-Ring
421	O-Ring
422	O-Ring
423	O-Ring
*424	O-Ring
600	Electric Motor

Mechanical Seal Application

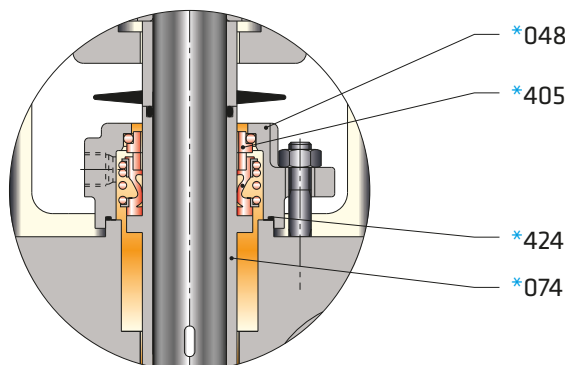

(*) Optional

Technical Data



Kalasanati.com

SKMV-H

Y View

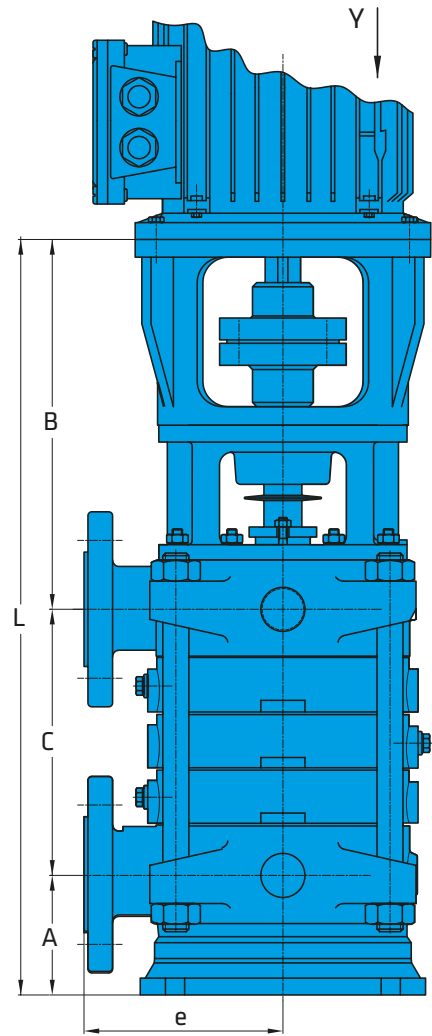
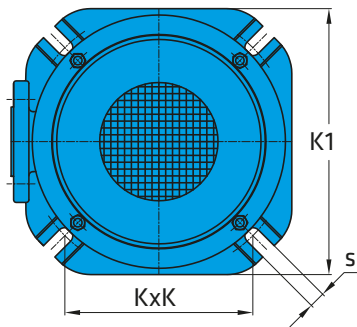

Bearing Type

Pump Type	Bearing Type
32	3305
40	3305
50	3306
65	3307
80	3308
100	3309
125	3310
150	3312

Shaft End Dimensions

Pump Type	d	l	t	u
32	22	50	25	6
40	22	50	25	6
50	28	65	31	8
65	32	65	35	10
80	38	80	41	10
100	42	110	45	12
125	48	110	51,5	14
150	55	110	59	16

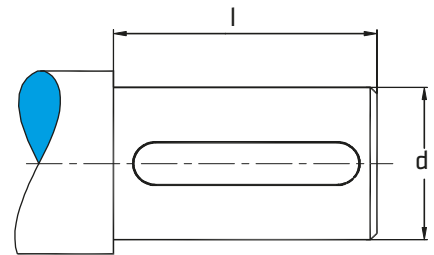
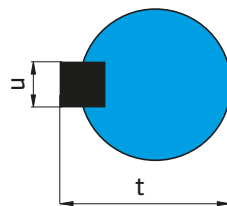

Flange Dimensions

EN 1092 - 2	DNe/DNb	Suction & Discharge (PN 16)				Suction & Discharge (PN 40)			
		Df	k	s	n	Df	k	s	n
	32	140	100	19	4	140	100	19	4
	40	150	110	19	4	150	110	19	4
	50	165	125	19	4	165	125	19	4
	65	185	145	19	4	185	145	19	8
	80	200	160	19	8	200	160	19	8
	100	220	180	19	8	235	190	23	8
	125	250	210	19	8	270	220	28	8
	150	285	240	23	8	300	250	28	8
	200	340	295	23	12	375	320	31	12

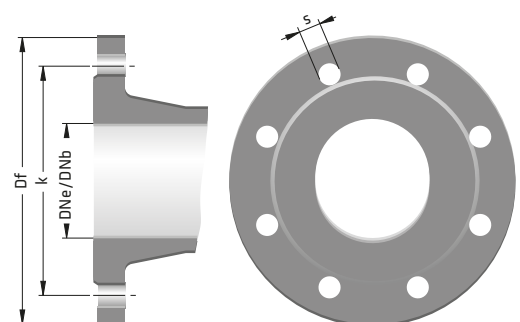

" n " number of holes



Kalasanati.com

1450 rpm

Pump Type	Motor No IEC	Dimensions (mm)										C (mm)													
		DNe	DNb	L	A	B	e	KxK	K1	s	Number of Stages														
											1	2	3	4	5	6	7	8	9	10	11	12	13	14	
32	80	40	32	399+C	105	298	155	212	300	18	71	114	157	200	243	286	329	372	415	458	501	544	587	630	
32	90	40	32	399+C	105	298	155	212	300	18	71	114	157	200	243	286	329	372	415	458	501	544	587	630	
32	100	40	32	409+C	105	308	155	212	300	18	71	114	157	200	243	286	329	372	415	458	501	544	587	630	
40	90	50	40	405+C	103	302	175	212	300	18	78	133	188	243	298	353	408	463	518	573	628	683	738	-	
40	100	50	40	415+C	103	312	175	212	300	18	78	133	188	243	298	353	408	463	518	573	628	683	738	-	
40	112	50	40	415+C	103	312	175	212	300	18	78	133	188	243	298	353	408	463	518	573	628	683	738	-	
40	132	50	40	435+C	103	332	175	212	300	18	78	133	188	243	298	353	408	463	518	573	628	683	738	-	
50	100	65	50	453+C	114	340	190	247	350	18	90	152	214	276	338	400	462	524	586	648	710	772	-	-	
50	112	65	50	453+C	114	340	190	247	350	18	90	152	214	276	338	400	462	524	586	648	710	772	-	-	
50	132	65	50	473+C	114	360	190	247	350	18	90	152	214	276	338	400	462	524	586	648	710	772	-	-	
50	160	65	50	503+C	114	390	190	247	350	18	90	152	214	276	338	400	462	524	586	648	710	772	-	-	
65	100	80	65	505+C	135	368	215	247	350	18	107	178	249	320	391	462	533	604	675	746	817	-	-	-	
65	112	80	65	505+C	135	368	215	247	350	18	107	178	249	320	391	462	533	604	675	746	817	-	-	-	
65	132	80	65	525+C	135	388	215	247	350	18	107	178	249	320	391	462	533	604	675	746	817	-	-	-	
65	160	80	65	555+C	135	420	215	247	350	18	107	178	249	320	391	462	533	604	675	746	817	-	-	-	
65	180	80	65	555+C	135	420	215	247	350	18	107	178	249	320	391	462	533	604	675	746	817	-	-	-	
80	132	100	80	568+C	145	423	265	247	350	23	112	195	278	361	444	527	610	693	776	859	942	-	-	-	
80	160	100	80	598+C	145	453	265	247	350	23	112	195	278	361	444	527	610	693	776	859	942	-	-	-	
80	180	100	80	598+C	145	453	265	247	350	23	112	195	278	361	444	527	610	693	776	859	942	-	-	-	
80	200	100	80	598+C	145	453	265	247	350	23	112	195	278	361	444	527	610	693	776	859	942	-	-	-	
80	225	100	80	628+C	145	483	265	247	350	23	112	195	278	361	444	527	610	693	776	859	942	-	-	-	
100	160	125	100	675+C	170	504	300	318	450	23	133	233	333	433	533	633	733	833	933	-	-	-	-	-	
100	180	125	100	675+C	170	504	300	318	450	23	133	233	333	433	533	633	733	833	933	-	-	-	-	-	
100	200	125	100	675+C	170	504	300	318	450	23	133	233	333	433	533	633	733	833	933	-	-	-	-	-	
100	225	125	100	705+C	170	534	300	318	450	23	133	233	333	433	533	633	733	833	933	-	-	-	-	-	
100	250	125	100	705+C	170	534	300	318	450	23	133	233	333	433	533	633	733	833	933	-	-	-	-	-	
100	280	125	100	705+C	170	534	300	318	450	23	133	233	333	433	533	633	733	833	933	-	-	-	-	-	
125	200	150	125	717+C	178	538	375	424	600	27	165	280	395	510	625	740	855	-	-	-	-	-	-	-	
125	225	150	125	747+C	178	568	375	424	600	27	165	280	395	510	625	740	855	-	-	-	-	-	-	-	
125	250	150	125	747+C	178	568	375	424	600	27	165	280	395	510	625	740	855	-	-	-	-	-	-	-	
125	280	150	125	747+C	178	568	375	424	600	27	165	280	395	510	625	740	855	-	-	-	-	-	-	-	
125	315	150	125	777+C	178	598	375	424	600	27	165	280	395	510	625	740	855	-	-	-	-	-	-	-	
150	250	200	150	888+C	265	623	425	424	600	27	218	363	508	653	798	-	-	-	-	-	-	-	-	-	
150	280	200	150	888+C	265	623	425	424	600	27	218	363	508	653	798	-	-	-	-	-	-	-	-	-	
150	315	200	150	918+C	265	653	425	424	600	27	218	363	508	653	798	-	-	-	-	-	-	-	-	-	

2900 rpm

Pump Type	Motor No IEC	Dimensions (mm)										C (mm)												
		DNe	DNb	L	A	B	e	KxK	K1	s	Number of Stage													
											1	2	3	4	5	6	7	8	9	10	11	12	13	
32	112	40	32	409+C	105	306	155	212	300	18	71	114	157	200	243	286	329	372	415	458	501	544	544	
32	132	40	32	429+C	105	326	155	212	300	18	71	114	157	200	243	286	329	372	415	458	501	544	544	
32	160	40	32	459+C	105	356	155	212	300	18	71	114	157	200	243	286	329	372	415	458	501	544	544	
40	132	50	40	435+C	103	332	175	212	300	18	78	133	188	243	298	353	408	463	518	573	628	683	-	
40	160	50	40	465+C	103	362	175	212	300	18	78	133	188	243	298	353	408	463	518	573	628	683	-	
40	180	50	40	465+C	103	362	175	212	300	18	78	133	188	243	298	353	408	463	518	573	628	683	-	
40	200	50	40	465+C	103	362	175	212	300	18	78	133	188	243	298	353	408	463	518	573	628	683	-	
40	225	50	40	495+C	103	392	175	212	300	18	78	133	188	243	298	353	408	463	518	573	628	683	-	
50	160	65	50	503+C	114	389	190	247	350	18	90	152	214	276	338	400	462	524	586	648	-	-	-	
50	180	65	50	503+C	114	389	190	247	350	18	90	152	214	276	338	400	462	524	586	648	-	-	-	
50	200	65	50	503+C	114	389	190	247	350	18	90	152	214	276	338	400	462	524	586	648	-	-	-	
50	225	65	50	503+C	114	389	190	247	350	18	90	152	214	276	338	400	462	524	586	648	-	-	-	
50	250	65	50	533+C	114	419	190	247	350	18	90	152	214	276	338	400	462	524	586	648	-	-	-	
65	160	80	65	555+C	135	420	215	247	350	18	107	178	249	320	391	462	533	-	-	-	-	-	-	-
65	180	80	65	555+C	135	420	215	247	350	18	107	178	249	320	391	462	533	-	-	-	-	-	-	-
65	200	80	65	555+C	135	420	215	247	350	18	107	178	249	320	391	462	533	-	-	-	-	-	-	-
65	225	80	65	555+C	135	420	215	247	350	18	107	178	249	320	391	462	533	-	-	-	-	-	-	-
65	250	80	65	615+C	135	480	215	247	350	18	107	178	249	320	391	462	533	-	-	-	-	-	-	-
65	280	80	65	615+C	135	480	215	247	350	18	107	178	249	320	391	462	533	-	-	-	-	-	-	-
80	200	100	80	598+C	145	453	265	247	350	23	112	195	278	361	-	-	-	-	-	-	-	-	-	-
80	225	100	80	598+C	145	453	265	247	350	23	112	195	278	361	-	-	-	-	-	-	-	-	-	-
80	250	100	80	628+C	145	483	265	247	350	23	112	195	278	361	-	-	-	-	-	-	-	-	-	-
80	280	100	80	628+C	145	483	265	247	350	23	112	195	278	361	-	-	-	-	-	-	-	-	-	-



Technical Data

Kalasanati.com

PART LIST	0.6025	0.7040	0.7043	1.0619	1.4308	1.4309	1.4408	1.4409	1.4500	1.4517	1.4469	1.4317	1.4008	2.1050.01	2.0975.01	2.1096.01	1.0503	1.4021	1.4021+QT	1.4301	1.4404	1.4460	1.4462	Tungsten Carbide	
Suction Casing	●	○	○		○	○	○	○	○	○	○	○	○	○											
Discharge Casing	●	○	○		○	○	○	○	○	○	○	○	○	○											
Stage Casing	●	○	○		○	○	○	○	○	○	○	○	○	○											
Diffuser	●	○	○	○	○	○	○	○	○	○	○	○	○	○	○	○									
Impeller	●	○	○	○	○	○	○	○	○	○	○	○	○	○	○	○							○		
Shaft																		●	○	○	○			○	
Bearing Housing	●	○	○	○	○	○	○	○																	
Wear Ring (Casing)	○	○	○	○	○	○	○	○	○	○	○	○	○	○	○	○									
Shaft Sleeve																		●	○	○	○	○		○	
Shaft Pro. Sleeve																		●	○	○	○	○		○	
Spacer Sleeve																		●	○	○	○	○		○	
Sleeve Bearing														●											○
Mechanical Seal (*)	EN 12756																								

(*) Optional :Depending on customer requirement or request different types and brands of mechanical seals are applicable. ● Standard manufacturing ○ Optional

Material Equivalents

Description	DIN / EN		AISI / SAE / ASTM
Cast Iron	0.6025	EN-GJL-250 (GG25)	A48 Class 40B
Nodular Cast Iron	0.7040	EN-GJS-400-15 (GGG40)	A536 60-40-18
Nodular Cast Iron	0.7043	EN-GJS-400-18-LT (GGG40.3)	A536 60-40-18
Cast Steel	1.0619	GP240GHGS-C25	A216 WCB
Chrome Nickel Cast Steel	1.4308	GX5CrNi19-10	A351 CF8
Chrome Nickel Cast Steel (low carbon)	1.4309	GX2CrNi19-11	A351 CF3
Chrome Nickel Molybdenum Cast Steel	1.4408	GX5CrNiMo19-11-2	A351 CF8M
Chrome Nickel Molybdenum Cast Steel (low carbon)	1.4409	GX2CrNiMo19-11-2	A351 CF3M
Austenitic Cast Steel	1.4500	GX7NiCrMoCuNb25-20	A351 CN7M
Austenitic - Ferritic Cast Steel (duplex)	1.4517	GX2CrNiMoCuN25-6-3-3	A890 CD4MCuN
Austenitic - Ferritic Cast Steel (super duplex)	1.4469	GX2CrNiMoN26-7-4	A890 CE3MN
Martenzitic Stainless Cast Steel	1.4317	GX4CrNi13-4	A352 CA6NM
Martenzitic Stainless Cast Steel	1.4008	GX7CrNiMo12-1	A217 CA15
Cast Bronze (tin alloy)	2.1050.01	G-CuSn10	B427 C90700
Cast Bronze (nickel alloy)	2.0975.01	G-CuAl10Ni	B148 C95500
Cast Bronze (lead)	2.1096.01	G-CuSn5ZnPb	B584 C83600
Carbon Steel	1.0503	C45	AISI 1045
Chrome Steel	1.4021	X20Cr13	A276 Type 420
Chrome Steel (heat treated)	1.4021	X20Cr13	A276 Type 420+QT
Chrome Nickel Steel	1.4301	X5CrNi18-10	A276 Type 304
Chrome Nickel Steel (low carbon)	1.4404	X2CrNiMo17-12-2	A276 Type 316L
Duplex (austenitic-ferritic) Steel	1.4460	X3CrNiMoN27-5-2	AISI 329
Duplex (austenitic-ferritic) Steel	1.4462	X2CrNiMoN22-5-3	UNS S32205

Flange Positions

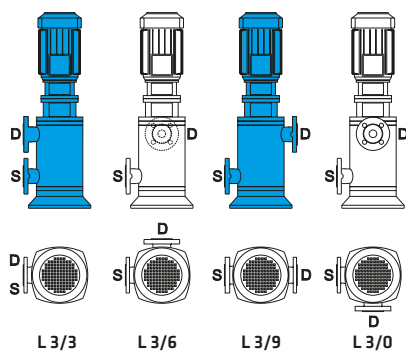

Explanation :

L 3 / 9

- └─ Discharge Flange Position (D)
- └─ Suction Flange Position (S)
- └─ Direction of Rotation (L)

Direction of rotation viewed from drive end
L : Left

Attention :

In the absence of specific request, pumps are supplied with the following nozzle arrangement:
 . L 3/9 : up to 2 stages
 . L 3/3 : 3 or more stages

SUBMERSIBLE SEWAGE PUMPS



Handled Liquids

Domestic and industrial waste water, raw sewage, liquids with fibrous and solid substances.

Technical Data

Discharge Flange _____ DN 50.....DN 300 mm

Capacity _____ up to 1600 m³/h

Head _____ up to 95 m

Speed _____ up to 2900 rpm

Design Temperature _____ up to +40 °C*

Casing Pressure (Pmax) _____ 10 bar

(*) For higher temperatures, please contact with STANDART POMPA.

Design Features

- Vertical, wide volute casing, single stage, end suction submersible type centrifugal pump with enclosed, semi-open or vortex types impeller.
- 20 basic sizes covering wide range of operational area.
- Electric motor isolation class is IP 68.
- Discharge flanges conform to EN 1092-2 / PN 10. (EN 1092-1 / PN 10 for steel or stainless steel casing)

Pump Designation

Pump Type _____

Discharge Nozzle (DN-mm) _____

Impeller Nominal Diameter (mm) _____

Impeller Type _____

C 100 - 240 B

- All impellers are balanced dynamically or statically according to ISO 1940 class 6.3.
- Axial thrust is balanced by impeller back ribs.
- In case of request motor cooling jacket is also applicable (for pumps having bigger than 200 frame motor)
- Bearings of C type pumps are “life time grease lubricated” ball bearings.

Shaft Sealing

- For pumps bigger than 12 HP, always double mechanical seal is applied while for pumps up to 12 HP, single mechanical seal is applied as standard.
- In case of request, double mechanical seal can also be applied for pumps up to 12HP.

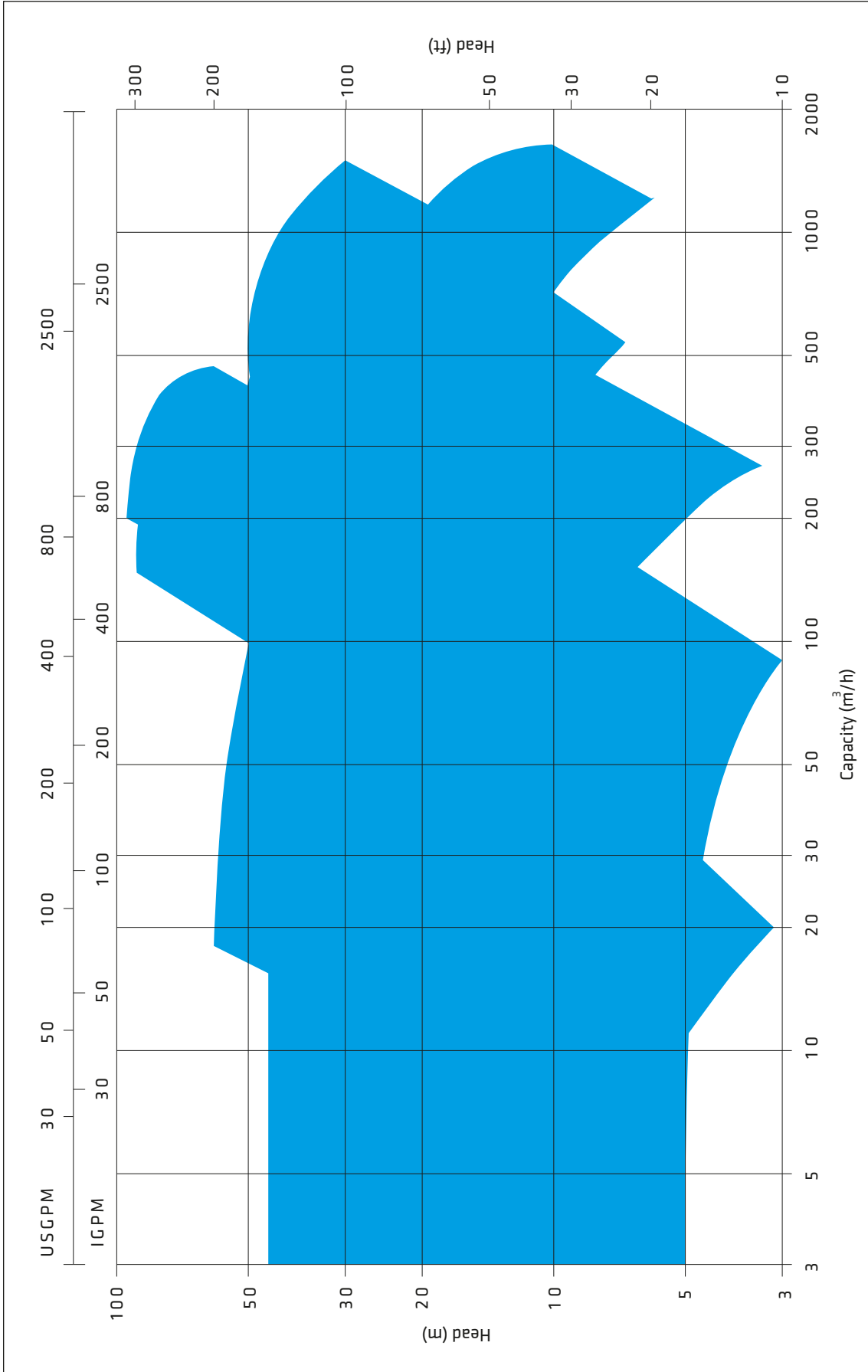

Sectional Drawing (up to 12 HP)

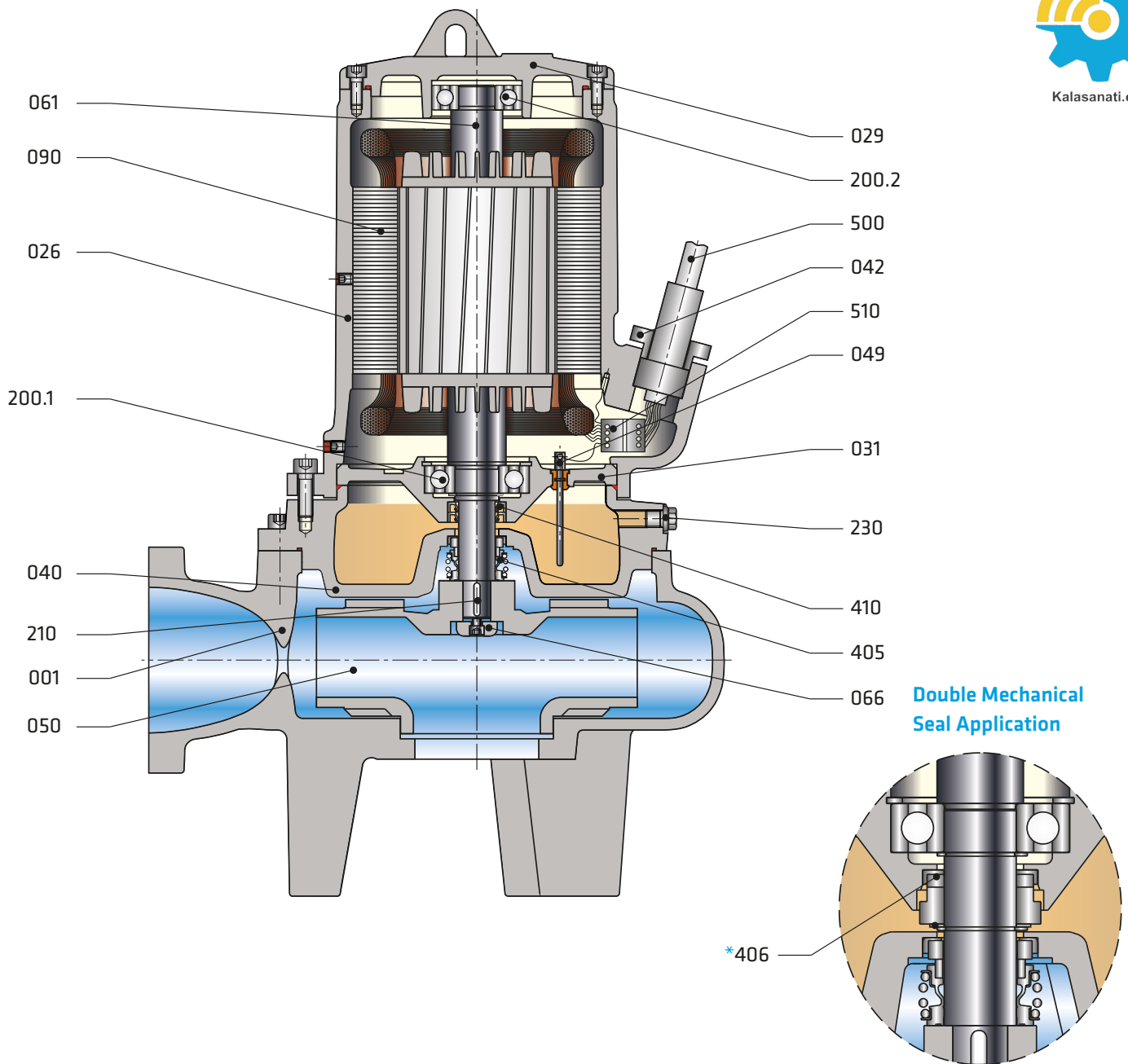

Part List

001	Volute Casing	090	Stator
026	Motor Casing	200.1	Bottom Bearing
029	Top Cover	200.2	Top Bearing
031	Bearing Housing	210	Impeller Key
040	Oil Chamber	230	Oil Plug
042	Gland	405	Mechanical Seal
049	Water Leakage Electrode	*406	Mechanical Seal
050	Impeller	410	Oil Seal
061	Rotor Shaft	500	Energy and Control Cable with Plug
066	Impeller Nut	510	Socket

(*) Optional

Sectional Drawing (bigger than 12 HP)

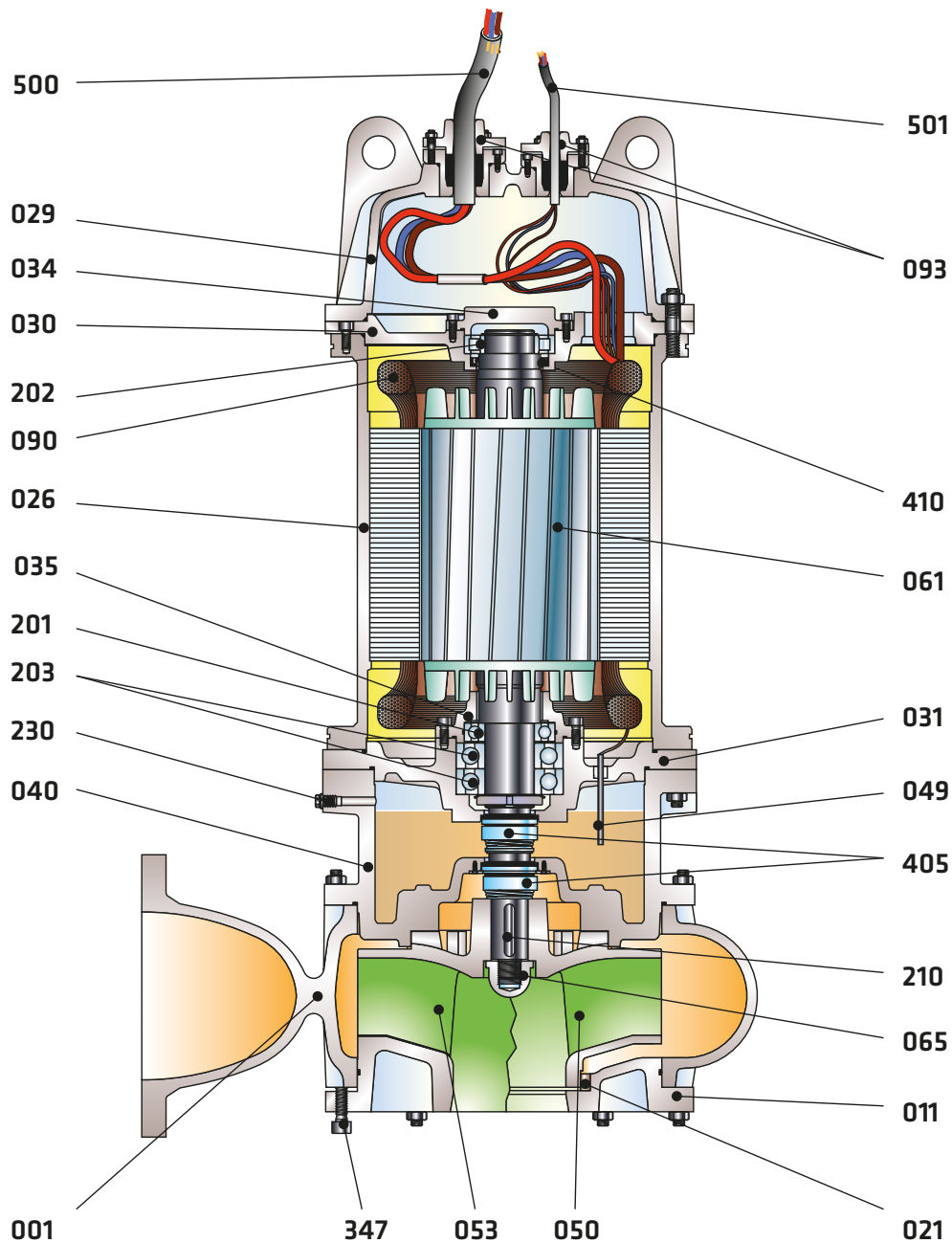

Part List

001	Volute Casing	040	Oil Chamber	202	Bottom Bearing
011	Bottom Cover	049	Water Leakage Electrode	203	Angular Contact Ball Bearing
021	Wear Ring	050	Closed Impeller	210	Impeller Key
026	Motor Casing	053	Semi-open Impeller	230	Oil Plug
029	Top Cover	061	Rotor Shaft	347	Adjustment Bolt
030	Top Bearing Housing	065	Impeller Nut	405	Mechanical Seal
031	Bottom Bearing Housing	090	Stator	410	Oil Seal
034	Top Bearing Cover	093	Gasket Compress Cover	500	Energy Cable
035	Bottom Bearing Cover	201	Bottom Bearing	501	Control Cable

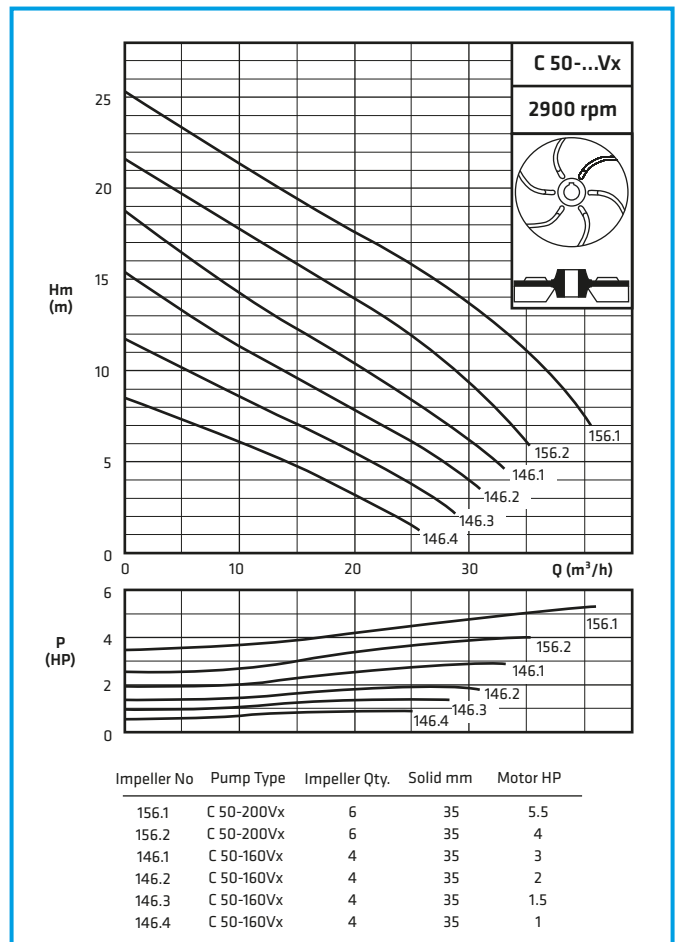
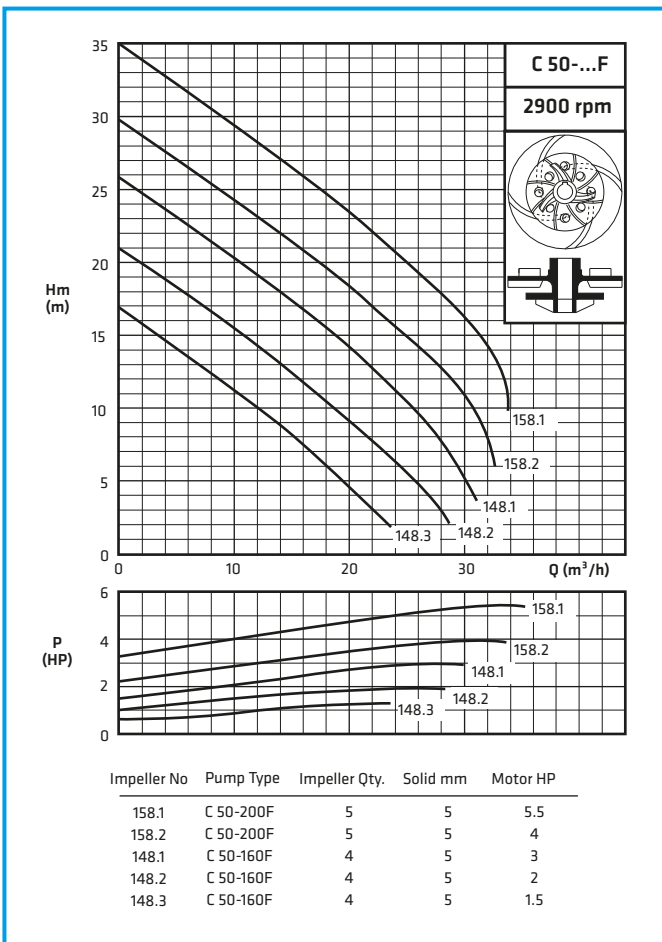
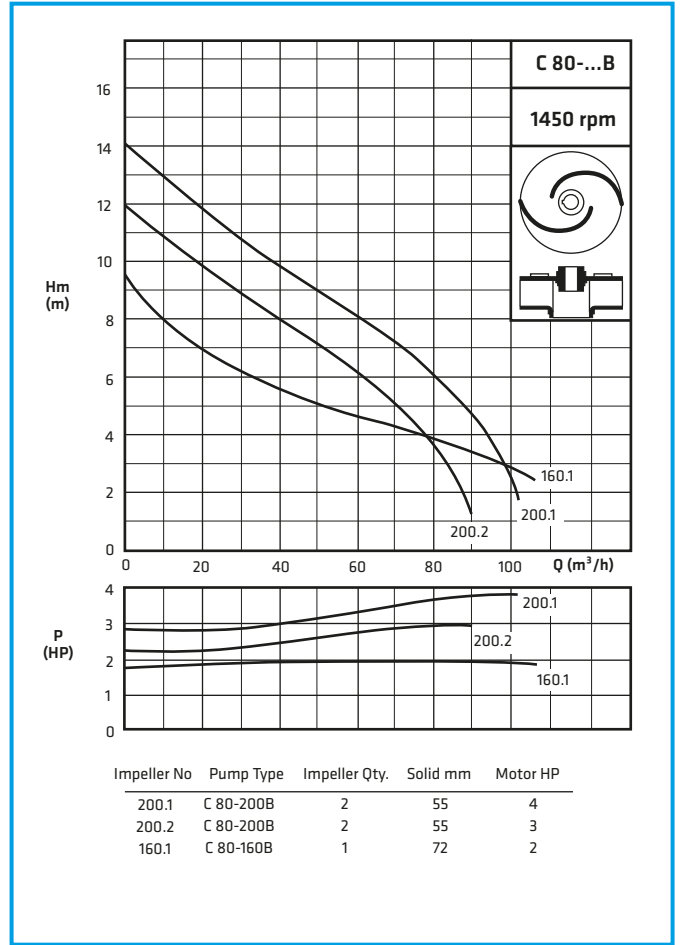
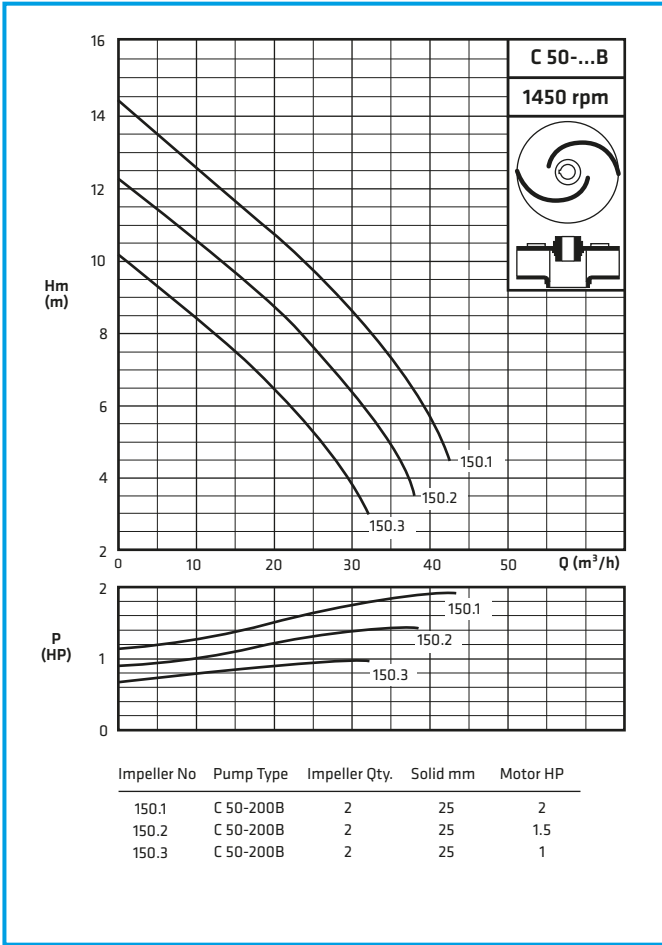



Field Chart

Kalasanati.com

C

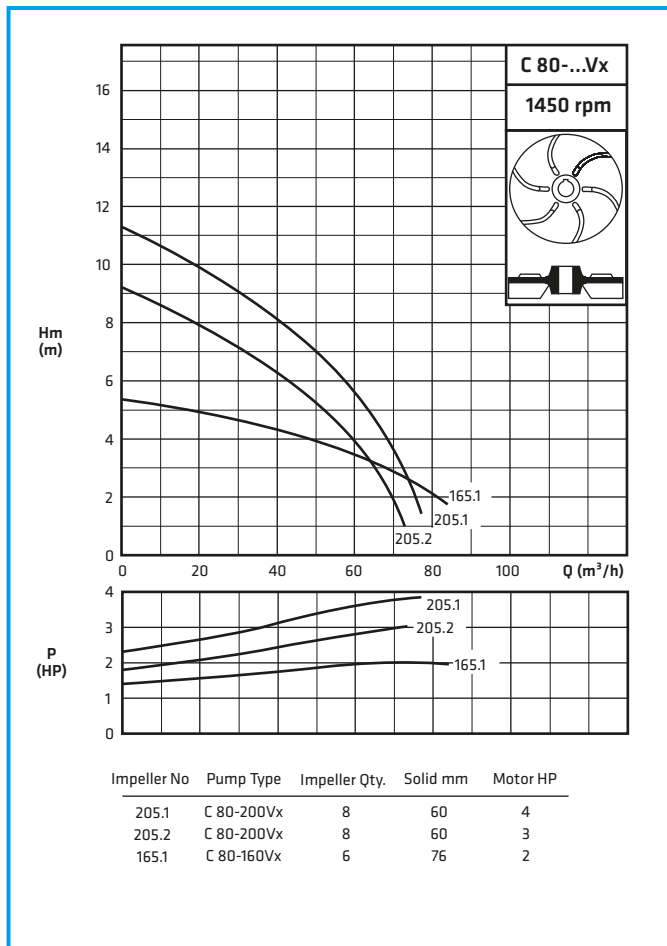
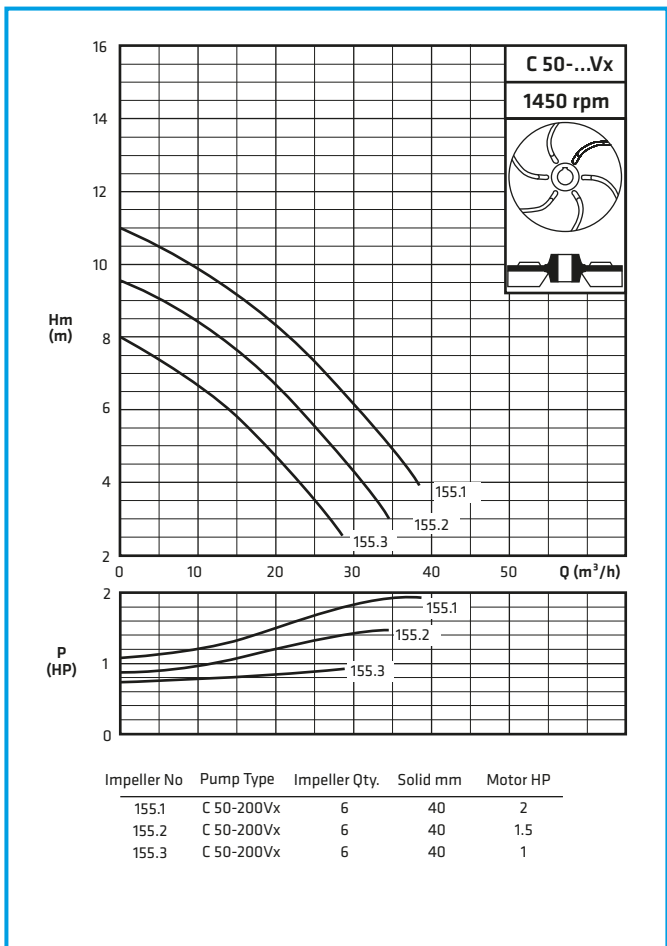
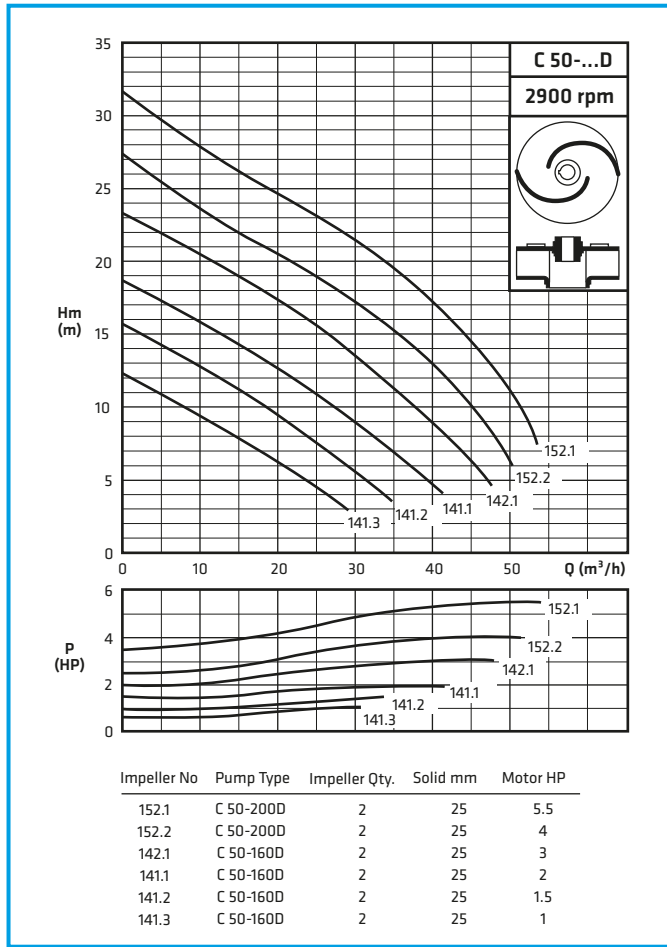
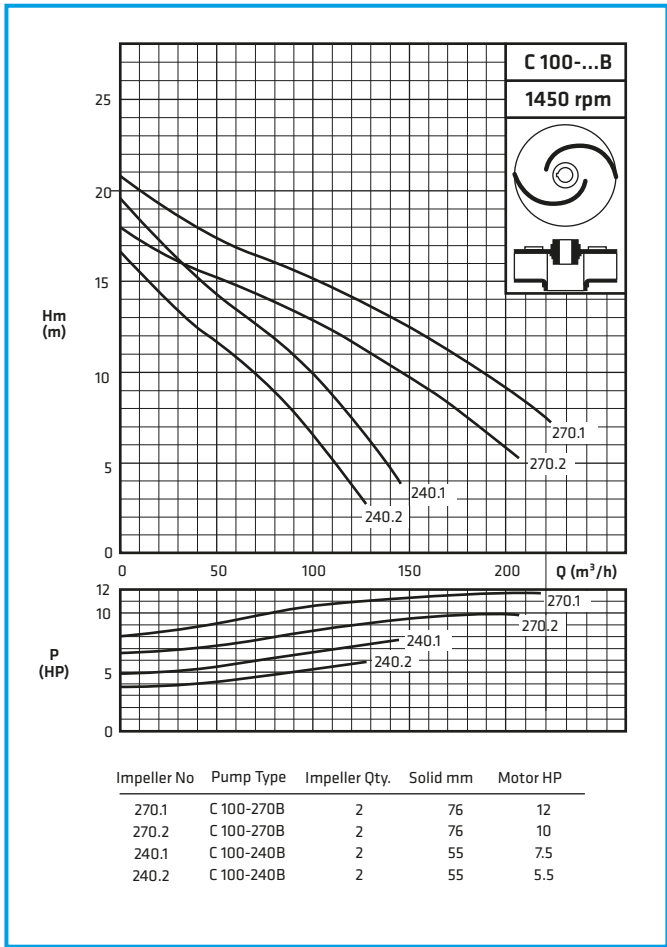



Field Chart

C

Kalasanati.com

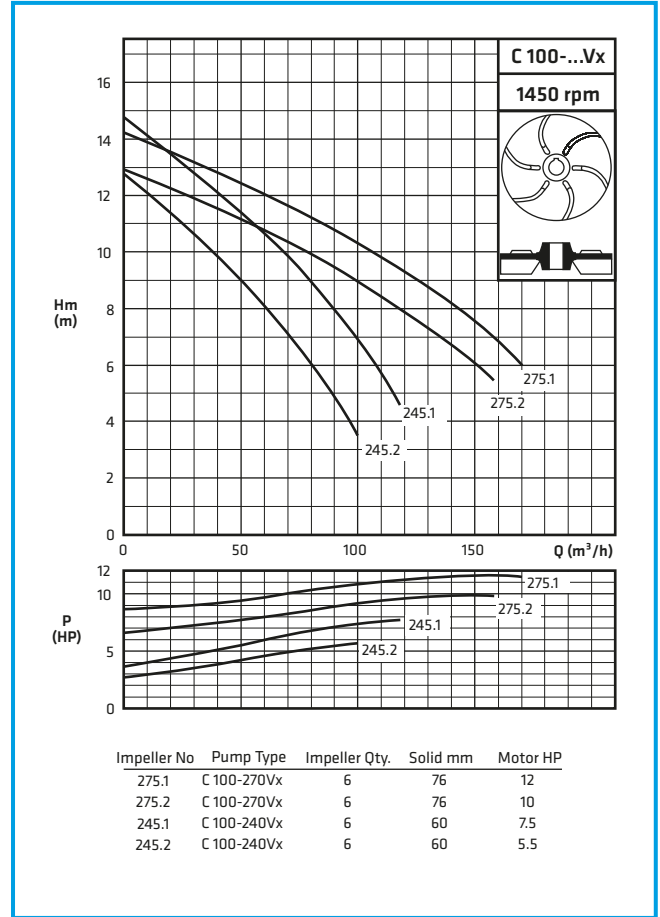
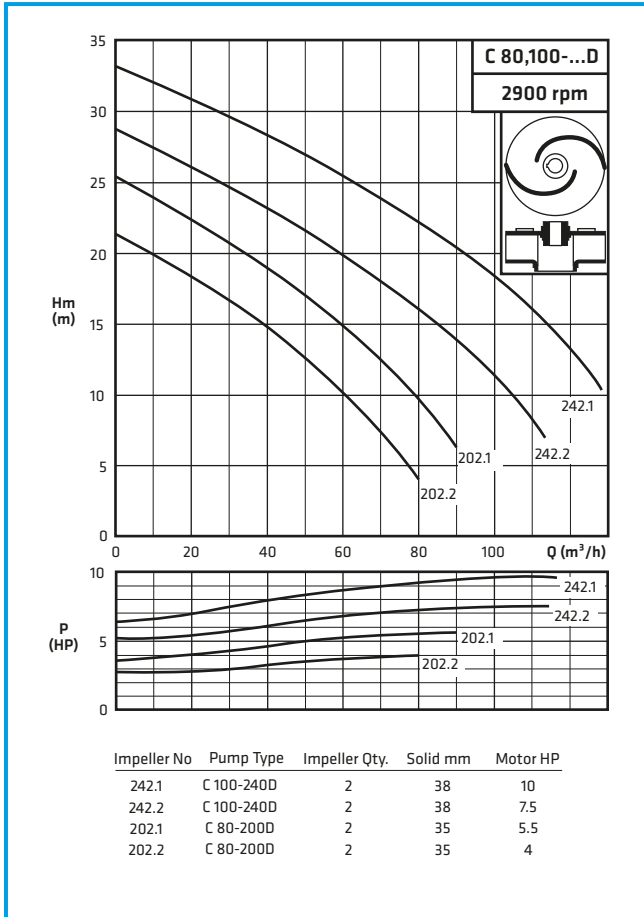

Material Options

PART LIST	0.6025	0.7040	1.0619	1.4308	1.4309	1.4408	1.4409	1.4517	1.4317	2.1050.01	2.0975.01	1.4021
Volute Casing	●	○	○	○	○	○	○	○	○	○		
Motor Casing	●	○		○	○	○						
Impeller	●	○	○	○	○	○	○	○	○	○	○	
Rotor Shaft												●
Oil Chamber	●	○										
Mechanical Seal	EN 12756 / DIN 24960											

● Standard manufacturing
○ Optional

Material Equivalents

Description	DIN / EN		AISI / SAE / ASTM
Cast Iron	0.6025	EN-GJL-250 (GG25)	A48 Class 40B
Nodular Cast Iron	0.7040	EN-GJS-400-15 (GGG40)	A536 60-40-18
Cast Steel	1.0619	GP240GHGS-C25	A216 WCB
Chrome Nickel Cast Steel	1.4308	GX5CrNi19-10	A351 CF8
Chrome Nickel Cast Steel (low carbon)	1.4309	GX2CrNi19-11	A351 CF3
Chrome Nickel Molybdenum Cast Steel	1.4408	GX5CrNiMo19-11-2	A351 CF8M
Chrome Nickel Molybdenum Cast Steel (low carbon)	1.4409	GX2CrNiMo19-11-2	A351 CF3M
Austenitic - Ferritic Cast Steel (duplex)	1.4517	GX2CrNiMoCuN25-6-3-3	A890 CD4MCuN
Martenzitic Stainless Cast Steel	1.4317	GX4CrNi13-4	A352 CA6NM
Cast Bronze (tin alloy)	2.1050.01	G-CuSn10	B427 C90700
Cast Bronze (nickel alloy)	2.0975.01	G-CuAl10Ni	B584 C83600
Chrome Steel	1.4021	X20Cr13	A276 Type 420

Technical Data (up to 12 HP) According to TS 12599

C

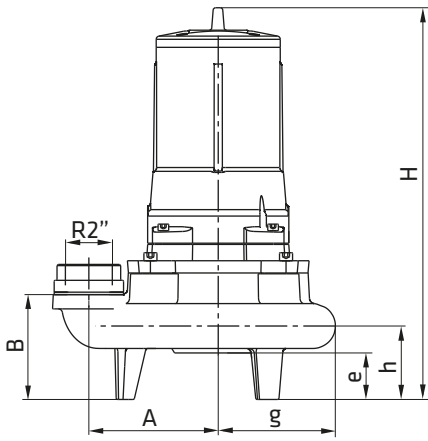

C 50 Hose Connection

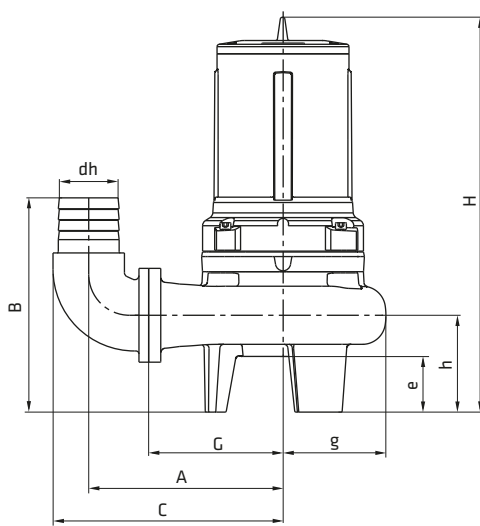

C 80-100 Hose Connection

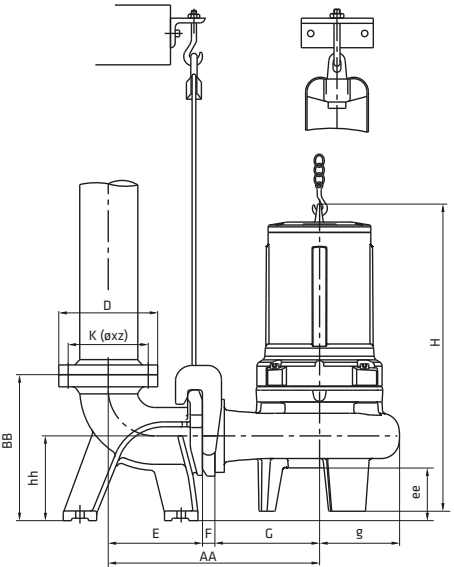

Kalasanati.com

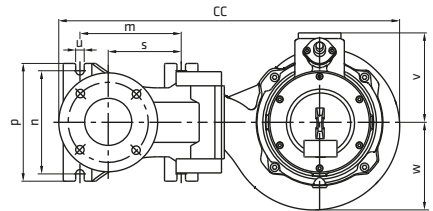

C 50-80-100 Auto Coupling Connection

Pump Type	Impeller Type	MOTOR			DISCHARGE		PUMP DIMENSIONS (mm)										Oil (ml)	Weight (kg)
		Power - HP	IEC No	2900	DN d	R"	A	B	C	e	h	H	G	g	v	w		
50-160	Vx	-	1	80	50	2"	139	131	-	55	90	430	185	114	130	125	750	29
50-160	Vx	-	1,5	80	50	2"	139	131	-	55	90	430	185	114	130	125	750	34
50-160	Vx	-	2	90	50	2"	139	131	-	55	90	475	185	114	138	125	750	38
50-160	Vx	-	3	90	50	2"	139	131	-	55	90	475	185	114	138	125	750	41
50-160	D	-	1	80	50	2"	139	131	-	55	90	430	185	114	130	125	750	32
50-160	D	-	1,5	80	50	2"	139	131	-	55	90	430	185	114	130	125	750	34
50-160	D	-	2	90	50	2"	139	131	-	55	90	475	185	114	138	125	750	39
50-160	D	-	3	90	50	2"	139	131	-	55	90	475	185	114	138	125	750	41
50-160	F	-	1,5	80	50	2"	139	131	-	55	90	412	185	114	130	125	750	33
50-160	F	-	2	90	50	2"	139	131	-	55	90	457	185	114	138	125	750	38
50-160	F	-	3	90	50	2"	139	131	-	55	90	457	185	114	138	125	750	40
50-200	Vx	1	-	80	50	2"	160	129	-	57	90	438	205	144	130	152	750	41
50-200	Vx	1,5	-	90	50	2"	160	129	-	57	90	483	205	144	138	152	750	45
50-200	Vx	2	-	90	50	2"	160	129	-	57	90	483	205	144	138	152	750	47
50-200	Vx	-	4	100	50	2"	160	129	-	57	90	524	205	144	148	152	1000	54
50-200	Vx	-	5,5	112	50	2"	160	129	-	57	90	529	205	144	158	152	1000	59
50-200	B	1	-	80	50	2"	160	129	-	57	90	438	205	144	130	152	750	41
50-200	B	1,5	-	90	50	2"	160	129	-	57	90	483	205	144	138	152	750	46
50-200	B	2	-	90	50	2"	160	129	-	57	90	483	205	144	138	152	750	48
50-200	D	-	4	100	50	2"	160	129	-	57	90	524	205	144	148	152	1000	54
50-200	D	-	5,5	112	50	2"	160	129	-	57	90	529	205	144	158	152	1000	60
50-200	F	-	4	100	50	2"	160	129	-	57	90	496	205	144	138	152	1000	52
50-200	F	-	5,5	112	50	2"	160	129	-	57	90	501	205	144	135	152	1000	58
80-160	Vx	2	-	90	80	-	262	287	304	62	133	540	180	130	138	146	1000	58
80-160	B	2	-	90	80	-	262	287	304	62	133	540	180	130	138	146	1000	58
80-200	Vx	4	-	100	80	-	282	286	324	70	132	573	200	150	148	168	1000	62
80-200	Vx	3	-	100	80	-	282	286	324	70	132	573	200	150	148	168	1000	58
80-200	B	4	-	100	80	-	282	286	324	70	132	573	200	150	148	168	1000	64
80-200	B	3	-	100	80	-	282	286	324	70	132	573	200	150	148	168	1000	60
80-200	D	-	4	100	80	-	282	286	324	70	132	573	200	150	148	168	1000	59
80-200	D	-	5,5	112	80	-	282	286	324	70	132	578	200	150	158	168	1000	65
100-240	Vx	5,5	-	112	100	-	324	356	383	94	162	608	225	170	158	186	1000	80
100-240	Vx	7,5	-	132	100	-	324	356	383	94	162	657	225	170	190	186	2000	101
100-240	B	5,5	-	112	100	-	324	356	383	94	162	608	225	170	158	186	1000	82
100-240	B	7,5	-	132	100	-	324	356	383	94	162	657	225	170	190	186	2000	104
100-240	D	-	7,5	132	100	-	324	356	383	94	162	657	225	170	190	186	2000	94
100-240	D	-	10	132	100	-	324	356	383	94	162	657	225	170	190	186	2000	103
100-270	Vx	10	-	132	100	-	359	364	418	88	170	678	260	211	198	228	2000	123
100-270	Vx	12	-	132	100	-	359	364	418	88	170	678	260	211	198	228	2500	123
100-270	B	10	-	132	100	-	359	364	418	88	170	678	260	211	198	228	2500	126
100-270	B	12	-	132	100	-	359	364	418	88	170	678	260	211	198	228	2500	126



Kalasanati.com

Impeller Type

C

B Type Impeller: Enclosed type impellers with wide channels capable of pumping large size solid particles without clogging, for big capacity and low pressure. It is mainly used for 4 pole motors.

D Type Impeller: It is also enclosed type like B type but suitable for high speed motors (2 pole). It is convenient for high pressure, small capacity and smaller size solid particles.

VX Type Impeller: Semi-open free vortex type impeller is placed on top of the volute. It creates a forced vortex motion in the casing. It is mostly suitable for fibrous materials. They are suitable for low head applications but pump efficiency is lower compare to other impeller types. The increased clearances limit the head that can be generated and reduce the attainable efficiency. Recessed type impellers are also possible for some models. With this type of design solid particles up to pump flanges size can pass through the pump. Please ask for more information.

F Type Impeller: Semi-open type impeller with cutter. The cutting system is placed in front of the impeller and it breaks up the solid particles into smaller sizes that makes passing possible through the smaller pipes without sticking. F type impeller is suitable for small capacity, high pressure, but the pump efficiency is also low.

AB Type Impeller: Semi-open type impellers with wide channels capable of pumping large size solid particles without clogging, for big capacity and low pressure. It is more suitable for 4 pole motors. Designed for aggressive applications. Impeller works against a wear plate. Clearance between the wear plate and impeller blades is between 0.25 - 0.40 mm.

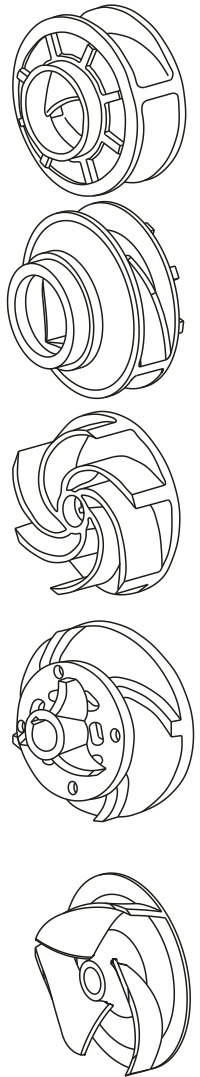

1 - Temperature **SENSOR** (130°C) in F class winding head protection for overheating.

2 - Signaling **ELECTRODE** in case of leakage into the motor or into the oil chamber.

3 - **MECHANICAL SEAL** running in pumping liquid.

4 - Demountable **TOP COVER** for easy motor winding.

5 - Oil filling and inspection **PLUG**.

6 - **BACK VANES** for reducing axial load and sealing pressure.

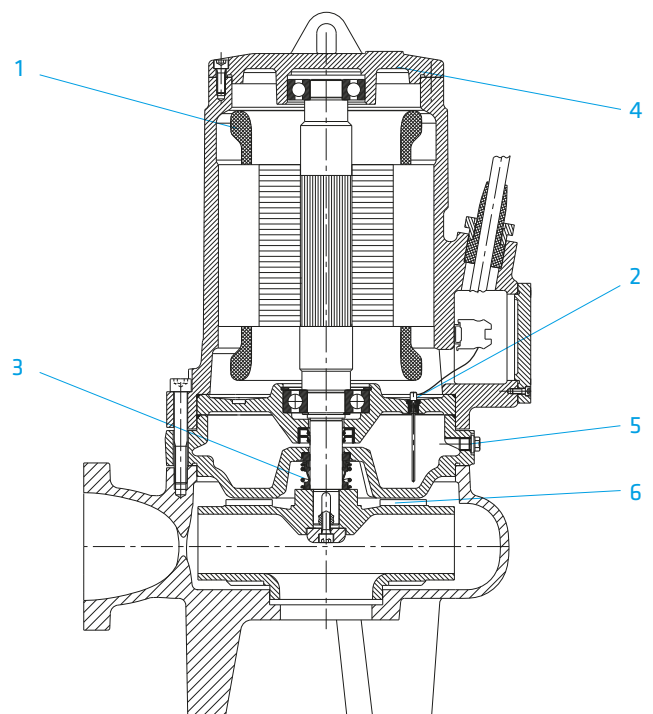

PCST3-V2 MOTOR PROTECTION AND CONTROL RELAY

C

Standart PCST3-V2 Motor Protection and Control Relay is an indispensable part of Standart C type pumps. It is supplied with the pump and it shall be used to secure smooth operation of motor and the pump.

FUNCTION:

When the device is switched on, all indicator lights blink in order and the control unit makes a self-check. If there is not any failure, NORMAL indicator light switches on in green indicating it is ready to run the motor.

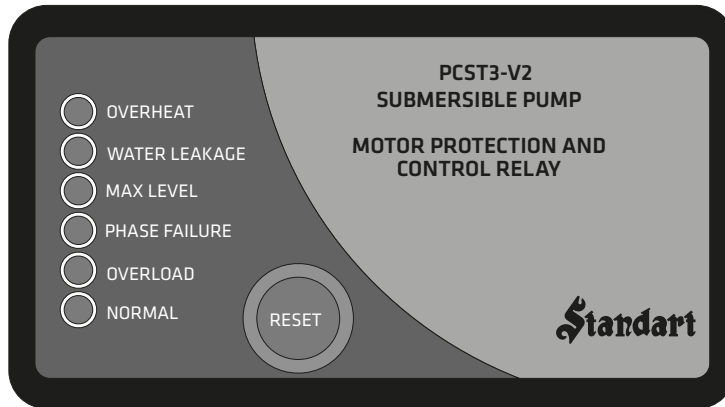

OVER HEAT

In case of overheating of motor windings, in which the temperature exceeds 130°C, the red indicator light switches on and the relay shuts down the motor. Indicator light blinks in short periods at alarming position. When motor has cooled down, relay restarts the motor while alarming goes on until the RESET button is pressed. Pressing the RESET button disables the alarm relay and indicator light stops blinking.

WATER LEAKAGE

In case of water leakage into the motor casing or oil chamber, red indicator light switches on and the relay shuts down the motor. Alarm relay becomes activated and until the RESET button is pressed, alarming goes on by blinking of red indicator light in short periods. When this failure occurs, the pump needs to be overhauled.

MAX LEVEL

When water level reaches the maximum level, which is set by the user, float switch sends an alarm signal and yellow indicator light starts blinking. This alarm does not affect the current state (run or stop) of the pump. Pressing the RESET button disables the alarm relay and indicator light stops blinking.

PHASE FAILURE

An external phase protection relay, mounted in the control panel, is connected to PCST3-V2 for checking phase sequence and phase failures. When there is a failure in mains voltage or in phase sequence, the motor is shut down by the relay and red indicator light starts blinking. By the time the failure is fixed, the motor restarts automatically while alarming goes on until the RESET button is pressed.

OVERLOAD

The relay shuts down the motor, if the current overload limit is exceeded. Meanwhile, alarm relay becomes activated and red indicator light starts blinking. As the failure is fixed, pressing the RESET button will disable the overload and the alarm relay, so the system turns back to normal conditions.

NORMAL

By the time all red indicator lights on PCST3-V2 switch off, green indicator light switches on, meaning that it is ready to run the motor. In case of failure, green indicator light switches off and the relay shuts down the motor.

PCST3-V2 is an indispensable part of Standart C type pumps. If it is damaged, do not try to operate the motor without it.

Waste Water Pump Station

Submersible pump and pumps in cabinet are type packages that contain vanes level control equipments and unit control systems. They offer an ideal for low level waste water pump stations.

This cabinet designs prevent groundwater pollution to a great extent and also prevent smelling.



Kalasanati.com

Technical Specifications

- Cabin Volume : 500 liters
- Quantity of Pump: 1 main + 1 spare
- Piping Diameter: DN 50
- Material : Polyester fiberglass composite
- Connection pipes, skid pipes, vane and checkvalves, including grid basket.
- Pipe Connections 2"
- Falling protection

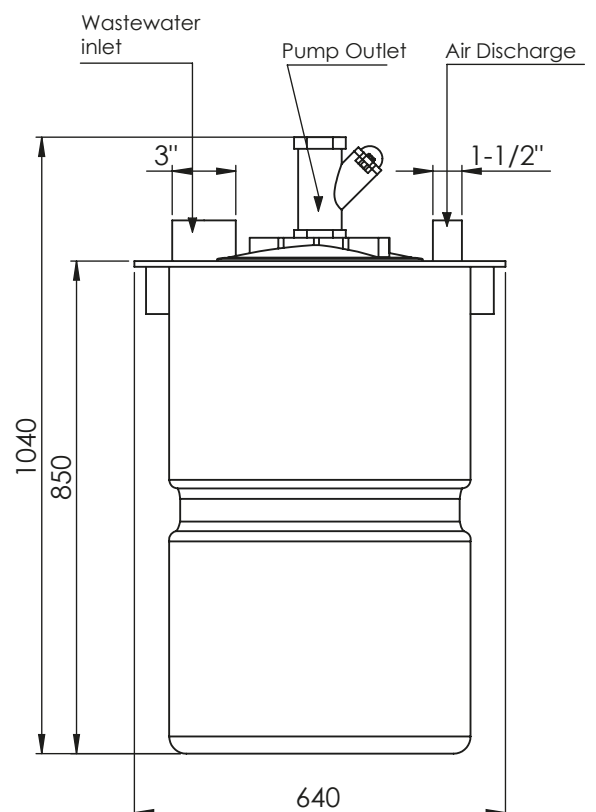
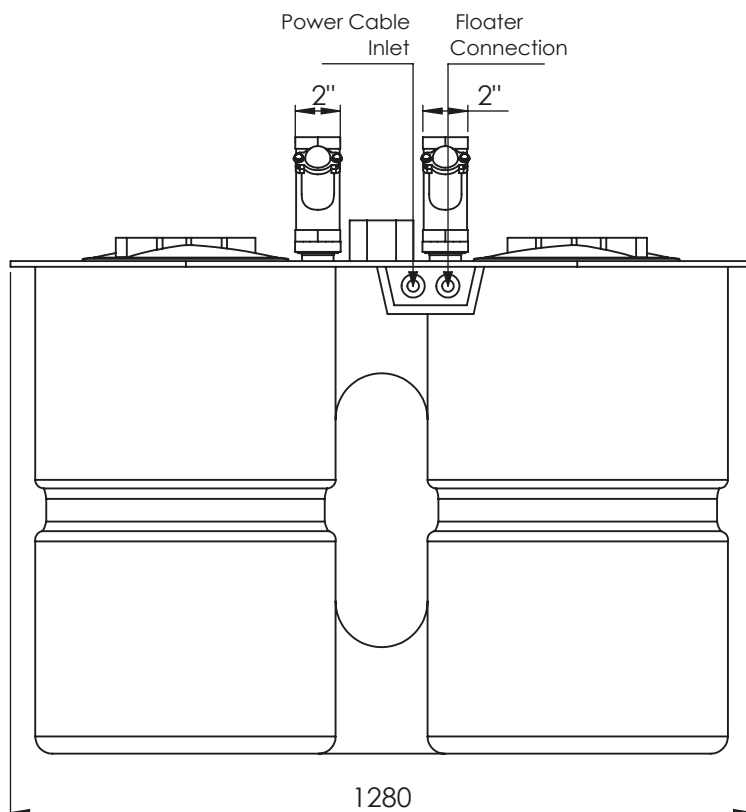



Kalasanati.com





Pump • Fire Fighting Units • Booster Set

PC / PC-VM

WASTE WATER AND PROCESS PUMPS



Kalasanati.com



Handled Liquids

Domestic and industrial waste water, raw sewage, viscous and corrosive liquids, liquids with fibrous and solid substances.

Technical Data

Discharge Flange _____ DN 40...DN 300 mm

Capacity _____ up to 1600 m³/h

Head _____ up to 95 m

Speed _____ up to 2900 rpm

Design Temperature _____ -10 °C up to +110 °C

Casing Pressure (Pmax) _____ 10 bar (16 bar)*

(Pmax: Suction Pressure + Shut off Head)

(*) The Material of pumps differ according to the type of pumped liquid, operating temperature and pressure. Contact for detailed information.

Desing Features

•Horizontal / Vertical, wide volute casing, single stage, end suction, centrifugal pumps with enclosed, semi-open or vortex type impeller.

•18 basic sizes covering wide range of operational area.

•Due to the back-pull-out design, the complete bearing assembly including impeller and casing cover can be dismantled without removing the volute casing from the pipe system. (With spacer coupling application, also possible to take out the rotor group without dismantling the electric motor.)

•Discharge flanges conform to EN 1092-2 / PN 10. (EN 1092-1 / PN 10 for steel or stainless steel casing)

•All impellers are balanced dynamically or statically according to ISO 1940 class 6.3.

•Axial thrust is balanced by impeller back ribs.

•Direction of rotation is clockwise viewed from drive end.

•Bearings of PC type pumps are "life time grease lubricated" ball bearing up to 150-315 size. For bigger sizes oil lubricated bearings are used. In vertical design (PC-VM) always grease lubricated bearings are used.

Shaft Sealing

•In standard production soft packed stuffing boxes are used.

•Depending on customer request, mechanical seals are available. In this case, pump shaft is always stainless steel.

•Only mechanical seal is applied for vertical type installation.

Pump Designation

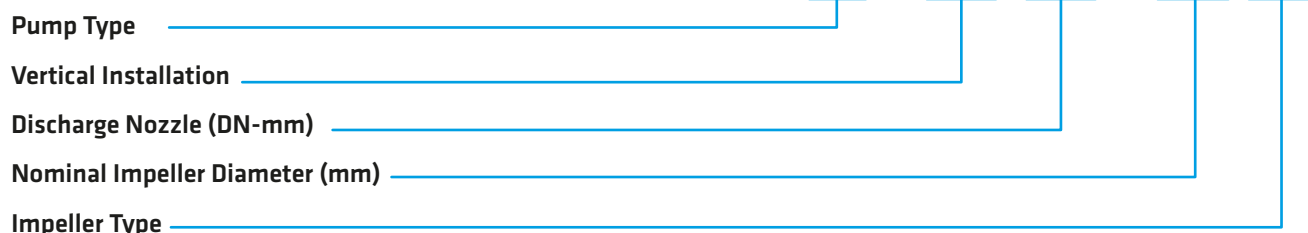

02.2020 / Rev. 3

Impeller Type



Kalasanati.com

PC / PC-VM

B Type Impeller: Enclosed type impellers with wide channels capable of pumping large size solid particles without clogging, for big capacity and low pressure. It is mainly used for 4 pole motors.

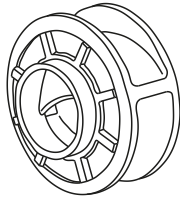

D Type Impeller: It is also enclosed type like B type but suitable for high speed motors (2 pole). It is convenient for high pressure, small capacity and smaller size solid particles.

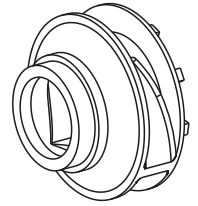

VX Type Impeller: Semi-open free vortex type impeller is placed on top of the volute. It creates a forced vortex motion in the casing. It is mostly suitable for fibrous materials. They are suitable for low head applications but pump efficiency is lower compare to other impeller types. The increased clearances limit the head that can be generated and reduce the attainable efficiency. Recessed type impellers are also possible for some models. With this type of design solid particles up to pump flanges size can pass through the pump. Please ask for more information.

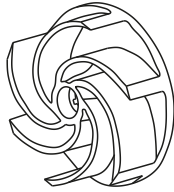

AB Type Impeller: Semi-open type impellers with wide channels capable of pumping large size solid particles without clogging, for big capacity and low pressure. It is more suitable for 4 pole motors. Designed for aggressive applications. Impeller works against a wear plate. Clearance between the wear plate and impeller blades is between 0.25 - 0.40 mm.

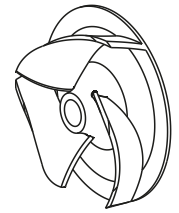

Field Chart

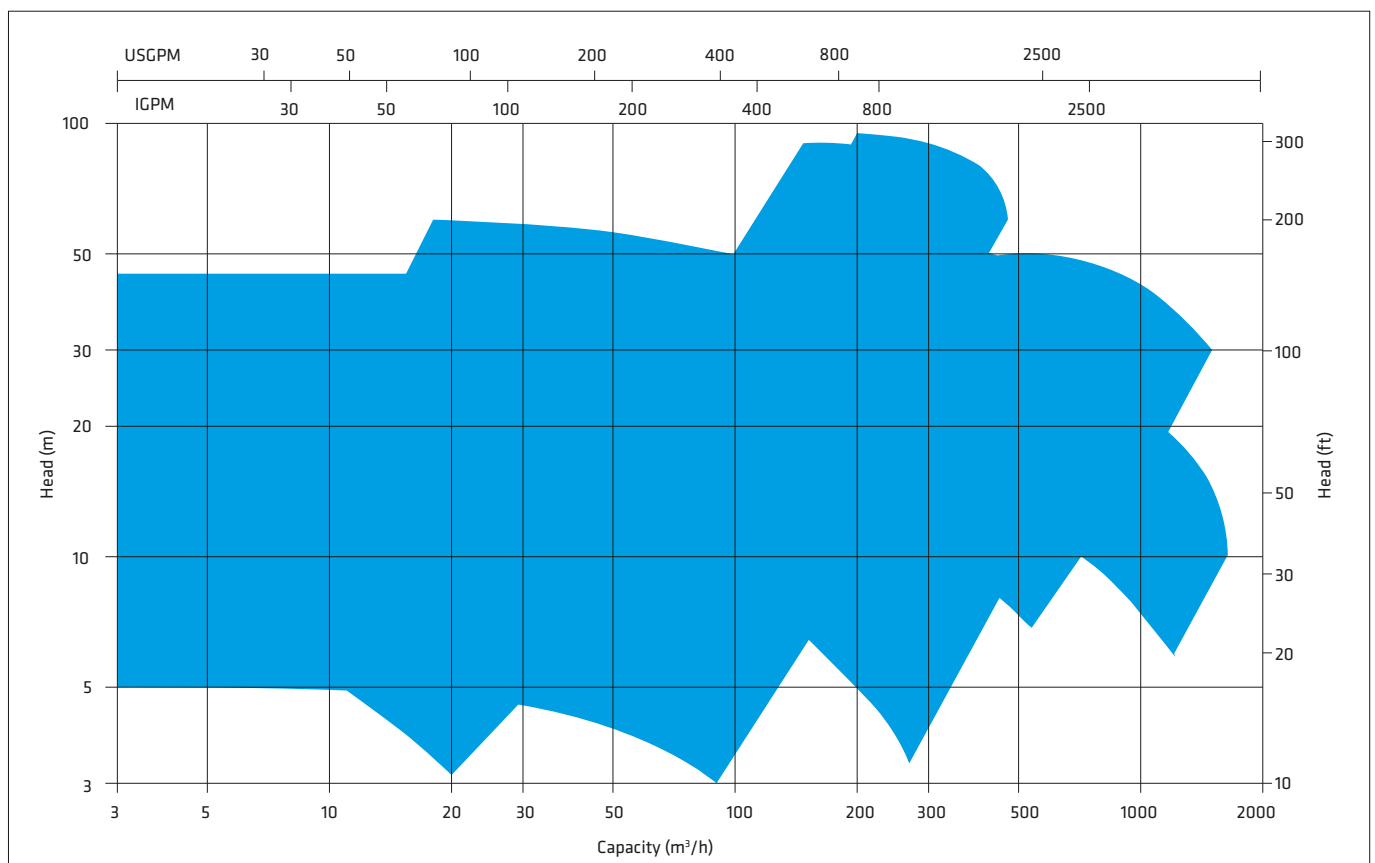

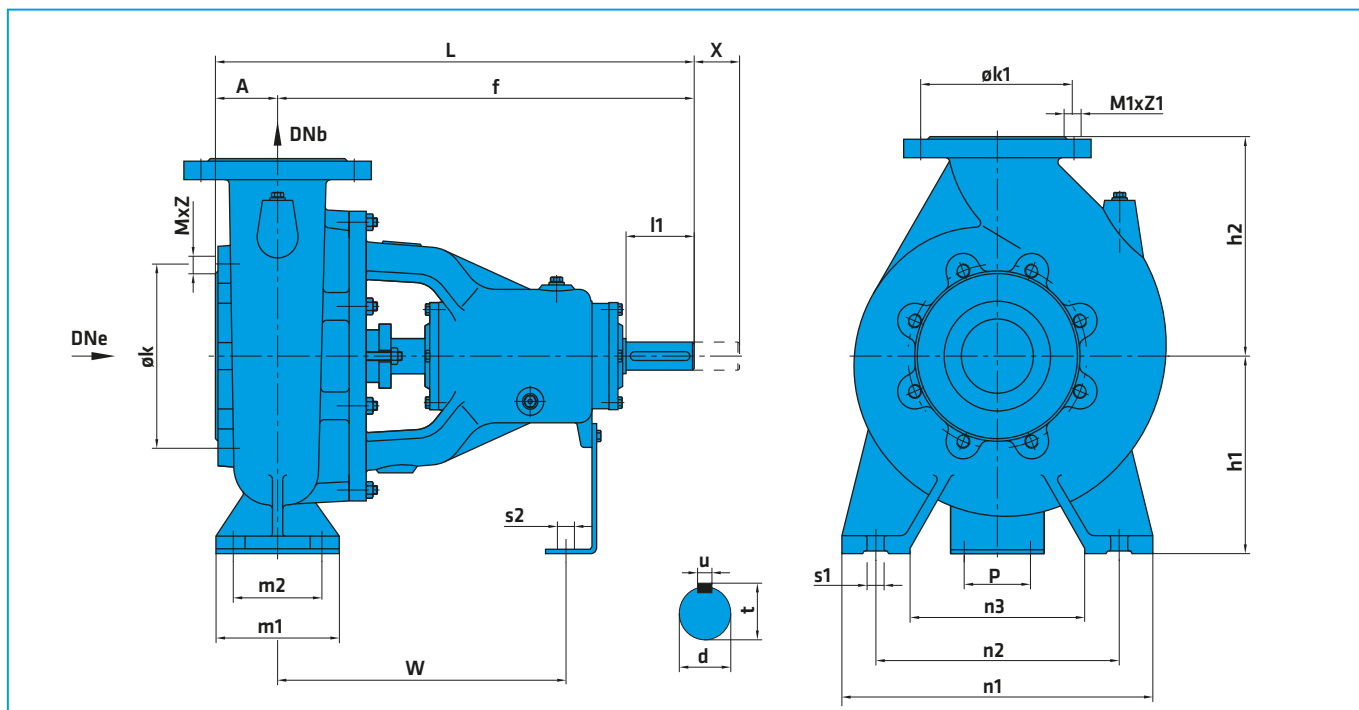

Pump Type	Overall Dimensions (mm)		Support & Foot Dimensions (mm)											Shaft (mm)				Flange Dimensions		Weight (kg)						
	DNc	DNb	A	f	L	h1	h2	m1	m2	n1	n2	n3	s1	P	s2	W	d	l1	t		u	x(**)	k	MxZ	k1	M1xZ1
40-160	50	40	82	348	430	160	180	100	70	240	190	140	14	110	14	247	24	50	27	8	140	125	M16x4	110	18x4	50
50-160	65	50	100	350	450	160	180	100	70	270	212	160	14	110	14	270	24	50	27	8	140	145	M16x4	125	18x4	50
50-200	65	50	105	370	475	160	200	100	95	270	210	160	14	110	14	270	24	50	27	8	140	145	M16x4	125	18x4	60
65-200	80	65	108	372	480	180	225	125	95	330	255	190	14	110	14	260	24	50	27	8	140	160	M16x8	145	18x4	65
80-160	100	80	83	384	467	180	180	120	85	310	250	190	14	110	14	288	24	50	27	8	140	180	M16x8	160	18x8	60
80-200	100	80	83	488	571	180	220	125	90	350	280	215	18	110	14	358	32	80	35	10	140	180	M16x8	160	18x8	70
80-315	100	80	55	480	535	250	310	125	95	400	315	240	18	110	14	350	32	80	35	10	140	180	M16x8	160	18x8	75
100-240	125	100	82	492	574	225	250	160	110	370	280	205	20	110	14	357	32	80	35	10	140	210	M16x8	180	18x8	100
100-270	125	100	97	500	597	275	310	160	110	430	345	270	20	110	14	371	32	80	35	10	140	210	M16x8	180	18x8	110
100-315	125	100	97	500	597	275	310	160	110	430	345	270	20	110	14	371	32	80	35	10	140	210	M16x8	180	18x8	120
150-315	150	150	119	638	757	280	355	200	150	500	400	300	23	110	14	445	42	110	45	12	200	240	M20x8	240	23x8	170
150-500	150	150	126	782	908	425	600	250	200	720	600	435	28	140	20	562	55	110	59	16	200	240	M20x8	240	23x8	580
200-315	200	200	165	707	872	355	450	250	200	600	500	360	24	110	14	543	48	110	51	12	250	295	M20x8	295	23x8	315
200-400	200	200	142	757	899	380	530	250	200	600	500	360	24	140	20	536	55	110	59	16	250	295	M20x8	295	23x8	370
200-500	150	200	126	968	1094	425	600	300	240	720	580	435	28	140	20	700	70	140	74,5	20	170	240	M20x8	295	23x8	600
250-315	200	250	145	1003	1148	335	475	300	230	680	540	400	27	140	20	730	70	140	74,5	20	265	295	M20x12	350	23x12	430
300-400	300	300	201	974	1175	400	560	300	240	720	600	435	27	140	20	730	75	140	79,5	20	285	400	M20x12	400	23x12	675
300-500	300	300	201	974	1175	450	600	300	230	800	660	520	27	140	20	700	75	140	79,5	20	300	400	M20x12	400	23x12	750

(*) Dimensions may differ according to bearing housing type (normal, heavy duty etc). We have rights to make change with the dimensions.
 (**) Gap necessary for the withdrawal of the pump rotor from the driven end without the need for disconnecting the motor and pipework (spacer coupling application).



Horizontal Installation (PC)

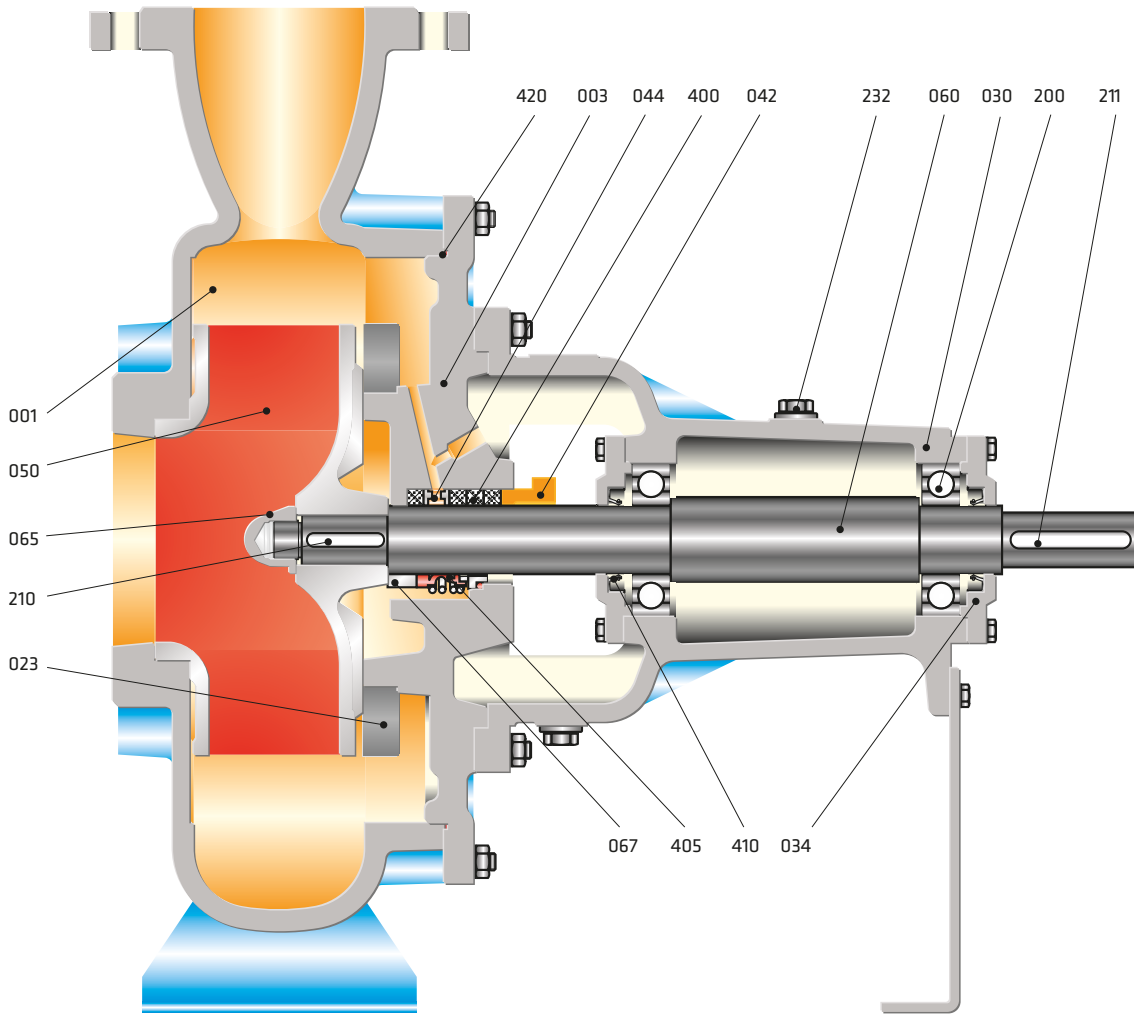

Semi-Open Impeller Application

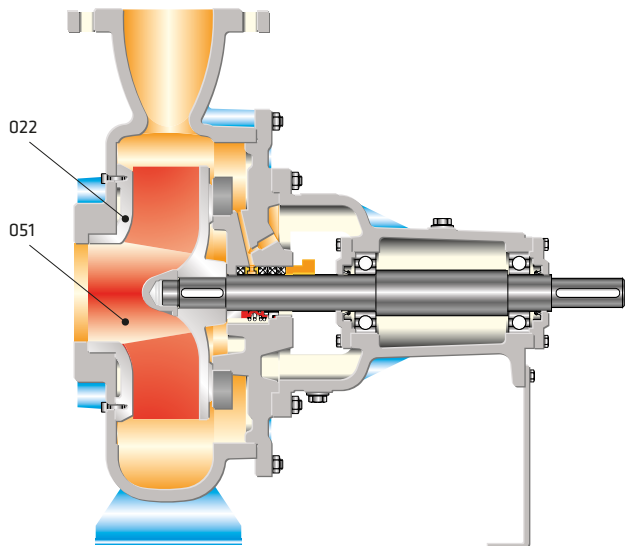

Heavy Duty Type Bearing Application

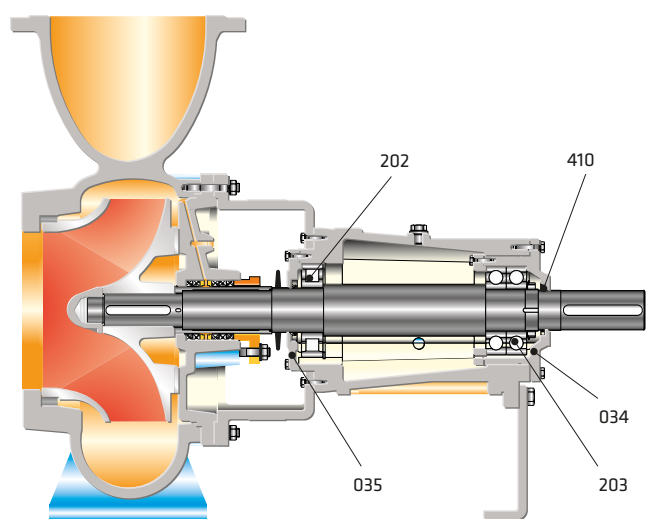



Vertical Installation (PC-VM)

Kalasanati.com

Part List

- 001 Volute Casing
- 003 Casing Cover
- 011 Elbow Foot
- 012 Motor Pedestal
- 022 Front Wear Plate
- 023 Back Wear Plate
- 030 Bearing Housing
- 034 Bearing Cover
- 035 Bearing Cover
- 042 Gland
- 044 Lantern Ring
- 050 Impeller
- 051 Semi-open Impeller
- 060 Pump Shaft
- 065 Impeller Nut
- 067 Spacer Sleeve
- 087 Flexible Coupling
- 200 Ball Bearing
- 202 Roller Bearing
- 203 Angular Contact Ball Bearing
- 210 Impeller Key
- 211 Coupling Key
- 232 Oil Filling Plug
- 400 Soft Packing
- 405 Mechanical Seal
- 410 Lip Seal
- 420 O-Ring
- 600 Electric Motor

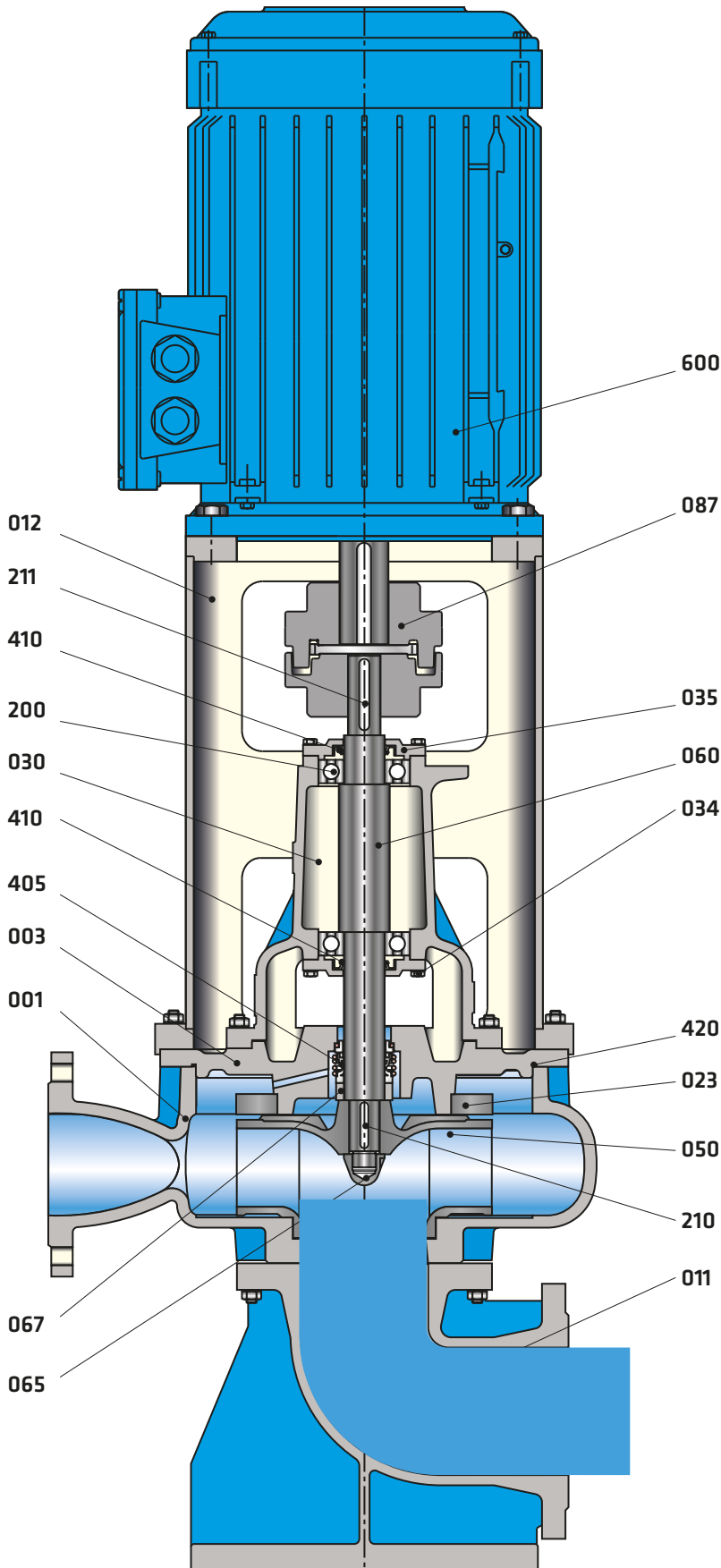



Kalasanati.com

Technical Data

PART LIST	0.6025	0.7040	0.7043	1.0619	1.4308	1.4309	1.4408	1.4409	1.4500	1.4517	1.4469	1.4317	1.4008	2.1050.01	2.0975.01	2.1096.01	1.0503	1.4021	1.4021+QT	1.4301	1.4404	1.4460	1.4462	
Volute Casing	●	○	○	○	○	○	○	○	○	○	○	○	○	○	○	○	○	○	○	○	○	○	○	○
Casing Cover	●	○	○	○	○	○	○	○	○	○	○	○	○	○	○	○	○	○	○	○	○	○	○	○
Impeller	●	○	○	○	○	○	○	○	○	○	○	○	○	○	○	○	○	○	○	○	○	○	○	○
Shaft																	●	○	○	○	○	○	○	○
Bearing Housing	●	○	○	○	○	○	○	○	○	○	○	○	○	○	○	○	○	○	○	○	○	○	○	○
Front Wear Plate	○	○	○	○	○	○	○	○	○	○	○	○	○	○	○	○	○	○	○	○	○	○	○	○
Back Wear Plate	●	○	○	○	○	○	○	○	○	○	○	○	○	○	○	○	○	○	○	○	○	○	○	○
Spacer Sleeve																	●	○	○	○	○	○	○	○
Mechanical Seal (*)	EN 12756																							

(*) Optional :Depending on customer requirement or request different types and brands of mechanical seals are applicable.

● Standard manufacturing
○ Optional

Material Equivalents

Description	DIN / EN		AISI / SAE / ASTM
Cast Iron	0.6025	EN-GJL-250 (GG25)	A48 Class 40B
Nodular Cast Iron	0.7040	EN-GJS-400-15 (GGG40)	A536 60-40-18
Nodular Cast Iron	0.7043	EN-GJS-400-18-LT (GGG40.3)	A536 60-40-18
Cast Steel	1.0619	GP240GHGS-C25	A216 WCB
Chrome Nickel Cast Steel	1.4308	GX5CrNi19-10	A351 CF8
Chrome Nickel Cast Steel (low carbon)	1.4309	GX2CrNi19-11	A351 CF3
Chrome Nickel Molybdenum Cast Steel	1.4408	GX5CrNiMo19-11-2	A351 CF8M
Chrome Nickel Molybdenum Cast Steel (low carbon)	1.4409	GX2CrNiMo19-11-2	A351 CF3M
Austenitic Cast Steel	1.4500	GX7NiCrMoCuNb25-20	A351 CN7M
Austenitic - Ferritic Cast Steel (duplex)	1.4517	GX2CrNiMoCuN25-6-3-3	A890 CD4MCuN
Austenitic - Ferritic Cast Steel (super duplex)	1.4469	GX2CrNiMoN26-7-4	A890 CE3MN
Martenzitic Stainless Cast Steel	1.4317	GX4CrNi13-4	A352 CA6NM
Martenzitic Stainless Cast Steel	1.4008	GX7CrNiMo12-1	A217 CA15
Cast Bronze (tin alloy)	2.1050.01	G-CuSn10	B427 C90700
Cast Bronze (nickel alloy)	2.0975.01	G-CuAl10Ni	B148 C95500
Cast Bronze (lead)	2.1096.01	G-CuSn5ZnPb	B584 C83600
Carbon Steel	1.0503	C45	AISI 1045
Chrome Steel	1.4021	X20Cr13	A276 Type 420
Chrome Steel (heat treated)	1.4021	X20Cr13	A276 Type 420+QT
Chrome Nickel Steel	1.4301	X5CrNi18-10	A276 Type 304
Chrome Nickel Steel (low carbon)	1.4404	X2CrNiMo17-12-2	A276 Type 316L
Duplex (austenitic-ferritic) Steel	1.4460	X3CrNiMoN27-5-2	AISI 329
Duplex (austenitic-ferritic) Steel	1.4462	X2CrNiMoN22-5-3	UNS S32205

Flange Dimensions

EN 1092 - 2

DNe/DNb	Suction & Discharge (PN 10)			
	Df	k	s	n
40	150	110	19	4
50	165	125	19	4
65	185	145	19	4
80	200	160	19	8
100	220	180	19	8
125	250	210	19	8
150	285	240	23	8
200	340	295	23	8
250	395	350	23	12
300	445	400	23	12

" n " number of holes



Pump • Fire Fighting Units • Booster Set

PC - V

WASTE WATER AND PROCESS PUMPS (SUMP DESIGN)



Kalasanati.com

Handled Liquids

Domestic and industrial waste water, raw sewage, viscous and corrosive liquids, liquids with fibrous and solid substances.

Technical Data

Discharge Flange _____ DN 40...DN 300 mm

Capacity _____ up to 1600 m³/h

Head _____ up to 95 m

Speed _____ up to 1450 rpm

Design Temperature _____ up to +95 °C

Casing Pressure (Pmax) _____ 10 bar

Design Features

- Vertical, wide volute casing, single stage, end suction, centrifugal pumps with enclosed, semi-open or vortex type impeller.
- Up to 4 m. column length.
- Discharge pipe is extended up to base plate for easy installation.
- Closed, semi-open or free vortex type impeller design.
- Discharge flanges conform to EN 1092-2 / PN 10. (EN 1092-1 / PN 10 for steel or stainless steel casing)



- All impellers are dynamically or statically balanced according to ISO 1940 Class 6.3.
- Axial thrust is balanced by impeller back ribs.
- Direction of rotation is clockwise viewed from drive end.
- Bearings of PC-V type pumps are grease lubricated. Bottom and internal sleeve bearings are lubricated by the pumping liquid. (different lubrication systems can be applied for the sleeve bearings in case of request or requirement. Contact for detailed information)

Shaft Sealing

- No sealing is required.

Pump Designation

Pump Type _____

Discharge Nozzle (DN-mm) _____

Nominal Impeller Diameter (mm) _____

Impeller Type _____

PC-V 250 - 315 AB

02.2020 / Rev. 3

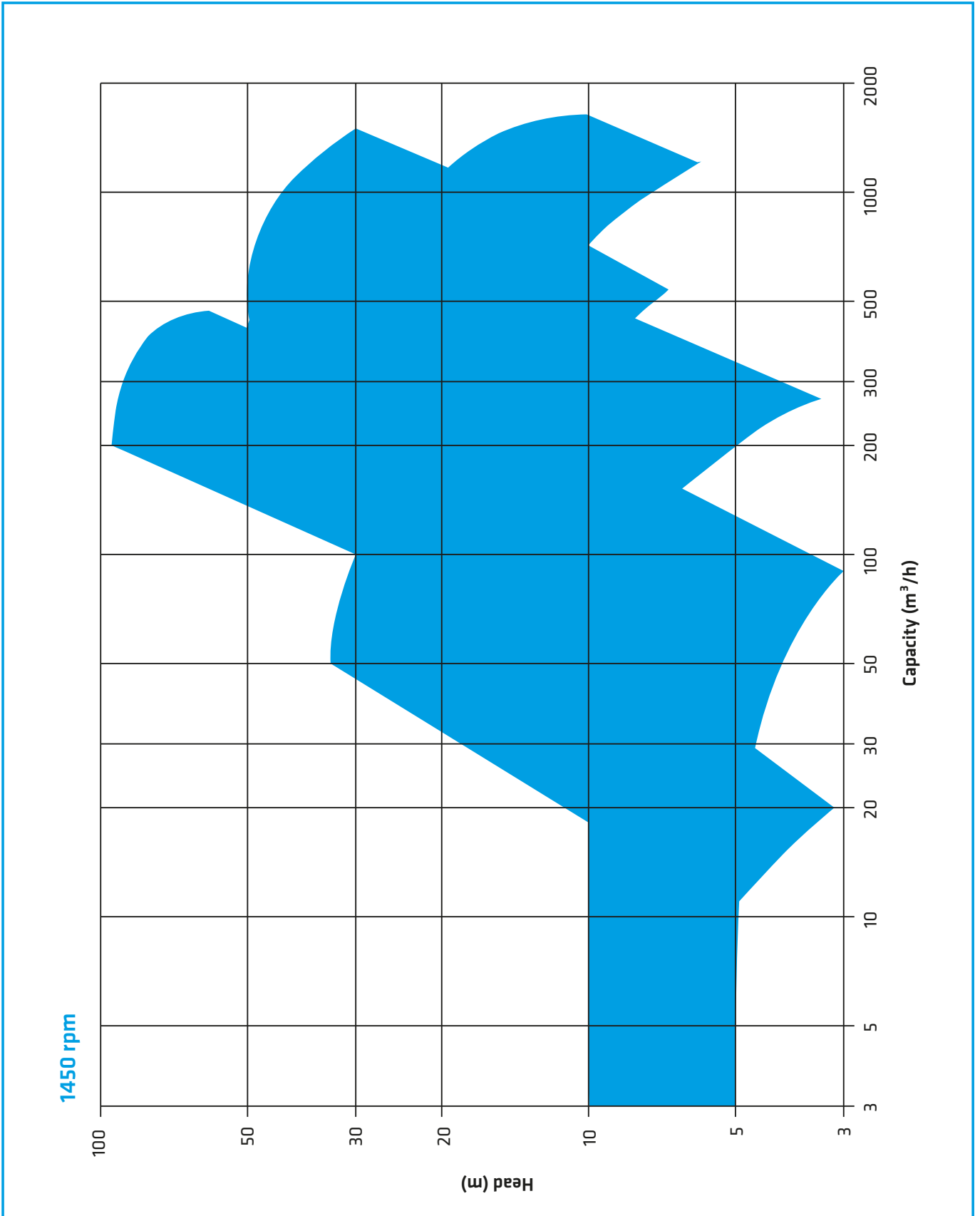



Kalasanati.com

Part List

- 001 Volute Casing
- 003 Casing Cover
- 011 Motor Pedestal
- 023 Back Wear Plate
- *022 Front Wear Ring
- 030 Bearing Housing (top)
- 031 Bearing Housing (bottom)
- 034 Bearing Cover (bottom)
- 035 Bearing Cover (top)
- 036 Sleeve Bearing
- 037 Sleeve Bearing Cover
- 050 Impeller
- 060 Shaft
- 065 Impeller Nut
- 087 Flexible Coupling
- 101 Column Pipe
- 201 Double Row Ball Bearing
- 202 Cylindrical Roller Bearing
- 210 Impeller Key
- 211 Coupling Key
- 220 Circlip
- 240 Discharge Pipe
- 245 Discharge Flange
- 281 Top Fixing Flange
- 282 Bottom Fixing Flange
- 283 Rubber Gasket
- 410 Oil Seal
- 420 O-Ring
- 421 O-Ring
- 600 Electric Motor
- 801 Base Plate

(*) Optional

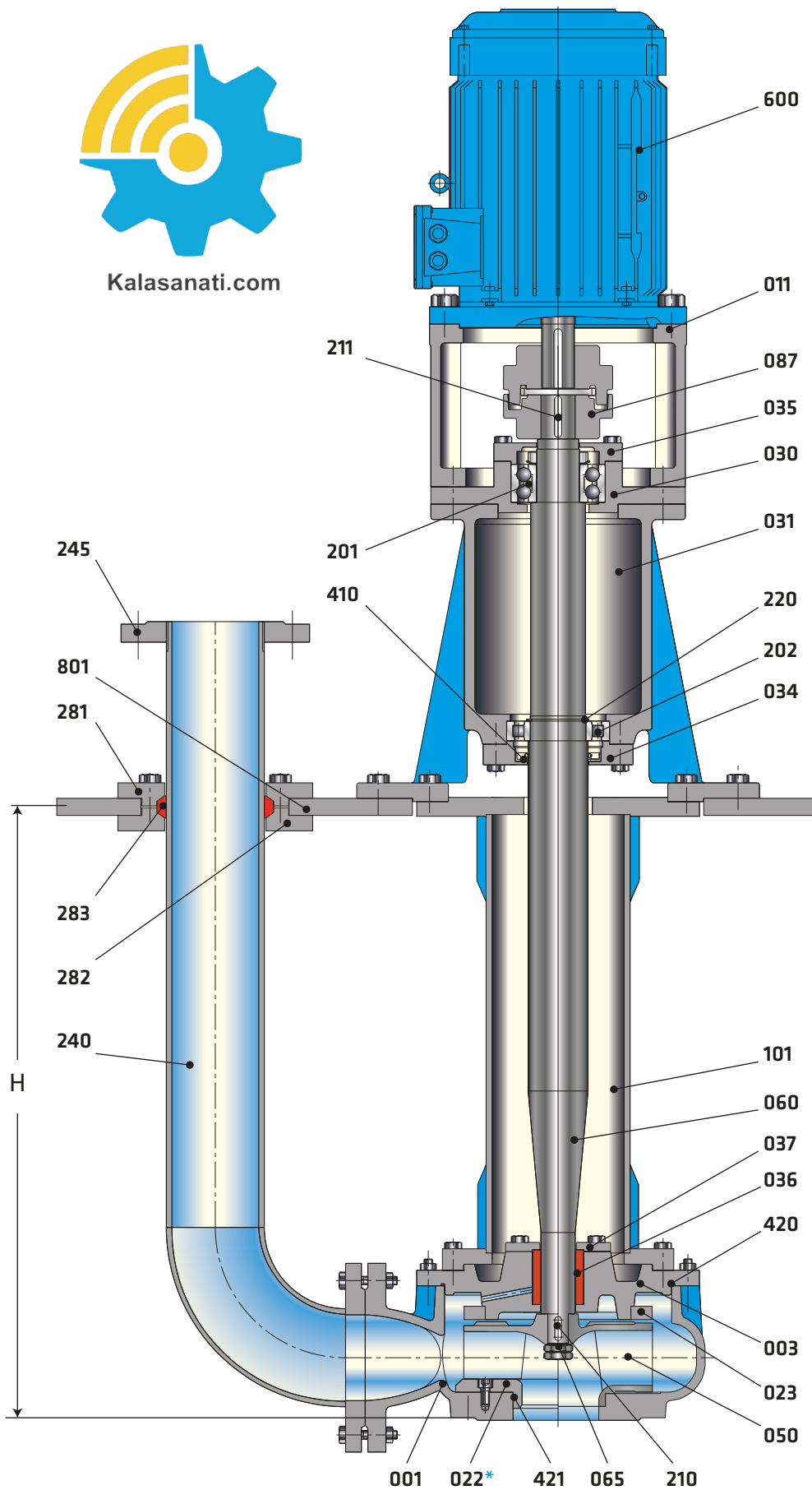



PART LIST	0.6025	0.7040	1.0619	1.4308	1.4309	1.4408	1.4409	1.4500	1.4517	1.4469	1.4317	1.4008	2.1050.01	2.0975.01	2.1096.01	1.0037	1.0503	1.4021	1.4021+QT	1.4301	1.4404	1.4460	1.4462	Tungsten Carbide	
Volute Casing	●	○	○	○	○	○	○	○	○	○	○	○	○	○	○	○									
Casing Cover	●	○	○	○	○	○	○	○	○	○	○	○	○	○	○	○									
Impeller	●	○	○	○	○	○	○	○	○	○	○	○	○	○	○	○						○			
Shaft																	●	○	○	○	○			○	
Bearing Housing	●	○	○	○	○	○	○																		
Column Pipe																●				○	○				
Front Wear Plate	○	○	○	○	○	○	○	○	○	○	○	○	○	○	○										
Back Wear Plate	●	○	○	○	○	○	○	○	○	○	○	○	○	○	○										
Sleeve Bearing													●												○

● Standard manufacturing
○ Optional

Material Equivalents

Description	DIN / EN		AISI / SAE / ASTM
Cast Iron	0.6025	EN-GJL-250 (GG25)	A48 Class 40B
Nodular Cast Iron	0.7040	EN-GJS-400-15 (GGG40)	A536 60-40-18
Nodular Cast Iron	0.7043	EN-GJS-400-18-LT (GGG40.3)	A536 60-40-18
Cast Steel	1.0619	GP240GHGS-C25	A216 WCB
Chrome Nickel Cast Steel	1.4308	GX5CrNi19-10	A351 CF8
Chrome Nickel Cast Steel (low carbon)	1.4309	GX2CrNi19-11	A351 CF3
Chrome Nickel Molybdenum Cast Steel	1.4408	GX5CrNiMo19-11-2	A351 CF8M
Chrome Nickel Molybdenum Cast Steel (low carbon)	1.4409	GX2CrNiMo19-11-2	A351 CF3M
Austenitic Cast Steel	1.4500	GX7NiCrMoCuNb25-20	A351 CN7M
Austenitic - Ferritic Cast Steel (duplex)	1.4517	GX2CrNiMoCuN25-6-3-3	A890 CD4MCuN
Austenitic - Ferritic Cast Steel (super duplex)	1.4469	GX2CrNiMoN26-7-4	A890 CE3MN
Martenzitic Stainless Cast Steel	1.4317	GX4CrNi13-4	A352 CA6NM
Martenzitic Stainless Cast Steel	1.4008	GX7CrNiMo12-1	A217 CA15
Cast Bronze (tin alloy)	2.1050.01	G-CuSn10	B427 C90700
Cast Bronze (nickel alloy)	2.0975.01	G-CuAl10Ni	B148 C95500
Cast Bronze (leaded)	2.1096.01	G-CuSn5ZnPb	B584 C83600
Steel	1.0037	St37	A 29 1015
Carbon Steel	1.0503	C45	AISI 1045
Chrome Steel	1.4021	X20Cr13	A276 Type 420
Chrome Steel (heat treated)	1.4021	X20Cr13	A276 Type 420+QT
Chrome Nickel Steel	1.4301	X5CrNi18-10	A276 Type 304
Chrome Nickel Steel (low carbon)	1.4404	X2CrNiMo17-12-2	A276 Type 316L
Duplex (austenitic-ferritic) Steel	1.4460	X3CrNiMoN27-5-2	AISI 329
Duplex (austenitic-ferritic) Steel	1.4462	X2CrNiMoN22-5-3	UNS S32205

Flange Dimensions

EN 1092 - 2

DNe/DNb	Suction & Discharge (PN 10)			
	Df	k	s	n
40	150	110	19	4
50	165	125	19	4
65	185	145	19	4
80	200	160	19	8
100	220	180	19	8
125	250	210	19	8
150	285	240	23	8
200	340	295	23	8
250	395	350	23	12
300	445	400	23	12

" n " number of holes

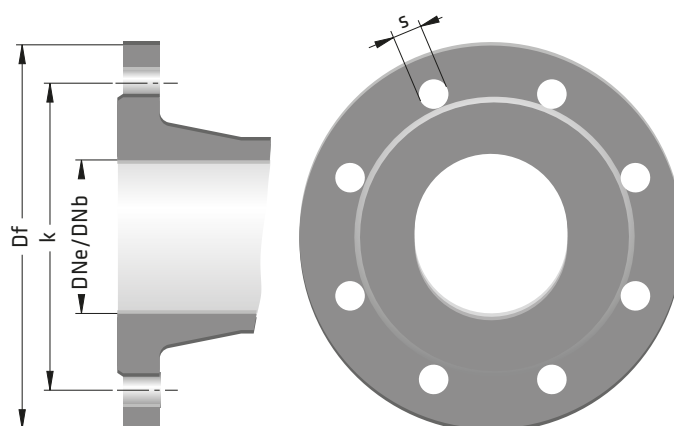



Pump • Fire Fighting Units • Booster Set

SKM-EVK PROCESS PUMPS (SUMP DESIGN)



Kalasanati.com

Handled Liquids

Clean or normal contaminated low or medium viscosity liquids without solid & fibrous particles.

Technical Data

Discharge Flange _____ DN 32...DN 150 mm

Capacity _____ up to 400 m³/h

Head _____ up to 220 m

Speed _____ up to 1450 rpm

Design Temperature _____ up to +95 °C

Casing Pressure (Pmax) _____ 30 bar

Design Features

- Vertical ring section, multistage, centrifugal pumps with closed impellers and diffusers.
- Up to 4 m. column length.
- Suction nozzle flanges conform to EN 1092 - 2 / PN 16 and discharge nozzle flanges conform to EN 1092 - 2 / PN 40 (PN 63) (For steel or stainless steel casing pumps, flanges conform to related pressure class ratings defined in EN 1092 - 1)
- All impellers are balanced dynamically or statically according to ISO 1940 class 6.3.
- Axial thrust is balanced by impeller balancing holes system.
- Direction of rotation is counter clockwise viewed from driver.

Pump Designation

Pump Type _____

Discharge Nozzle (DN-mm) _____

Nominal Impeller Diameter (mm) _____

SKM-EVK 40 / 3



- Bearings of SKM-EVK type pumps are grease lubricated. Bottom and internal sleeve bearings are lubricated by the pumping liquid. (different lubrication systems can be applied for the sleeve bearings in case of request or requirement. Contact for detailed information)

Shaft Sealing

- In standard production soft packed stuffing boxes are used.
- Depending on customer request, mechanical seals are available. In this case, pump shaft is always stainless steel.

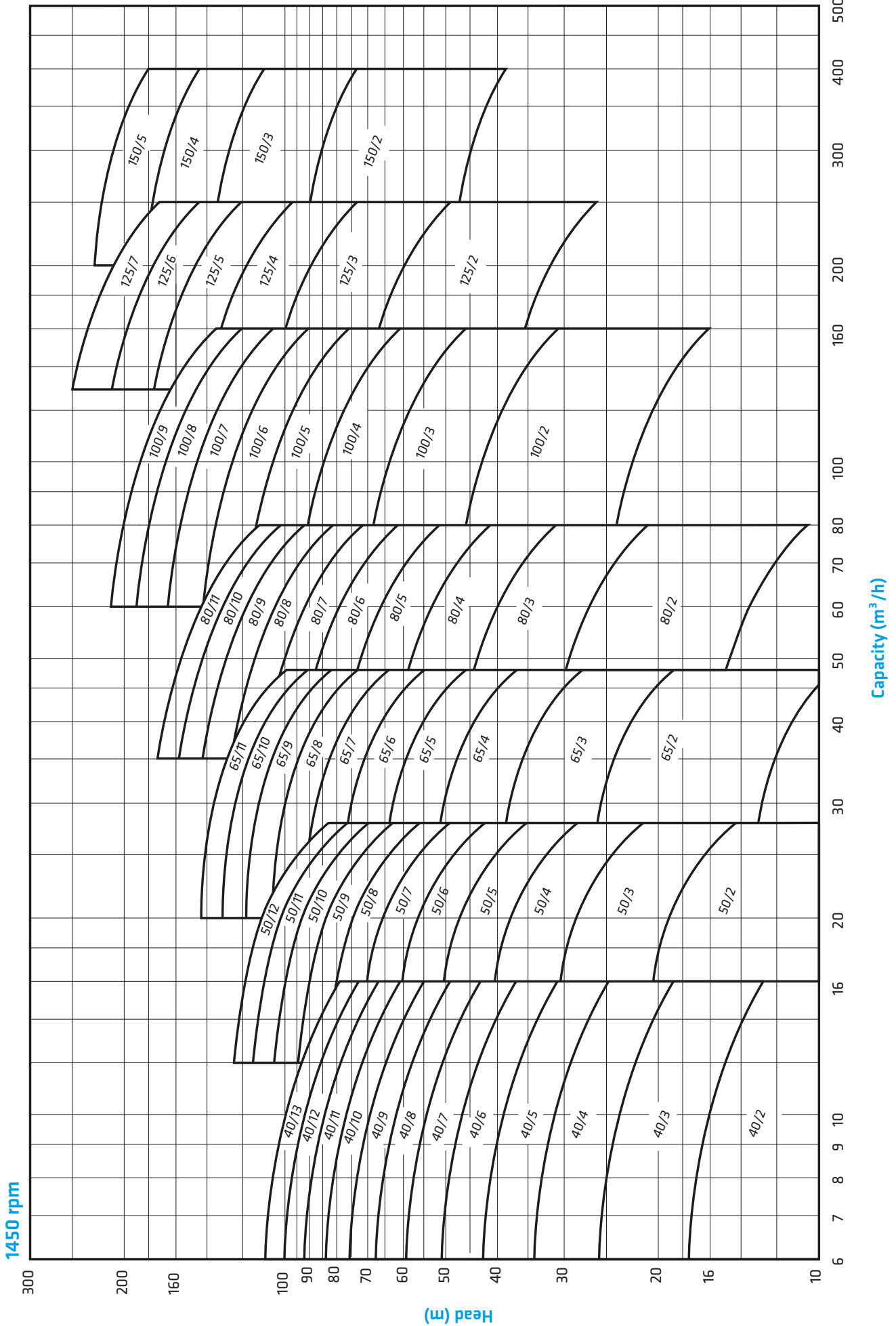



Part List

- 004 Suction Casing
- 005 Discharge Casing
- 011 Motor Pedestal
- 012 Bearing Housing
- 013 Column Pipe (Bottom)
- 014 Column Pipe (Up)
- 015 Diffuser
- 016 Base Plate
- 017 Intermediate Bearing Housing
- 018 Filter
- 019 Casing Flange
- *020 Wear Ring (Suction Casing)
- *021 Wear Ring (diffuser)
- *022 Wear Ring (Stage)
- 034 Bearing Housing Cover
- 042 Gland
- 044 Lantern Ring
- 050 Impeller
- 060 Shaft (Bottom)
- 061 Shaft (Up)
- 064 Impeller Nut
- 067 Interstage Sleeve
- 069 Intermediate Sleeve Bearing
- 070 Shaft Protecting Sleeve
- 071 Intermediate Bearing Sleeve
- 072 Spacer Sleeve
- 075 Bottom Sleeve Bearing
- 090 Flexible Coupling
- 091 Rigid Coupling
- 106 Stage Casing
- 200 Bearing
- 210 Impeller Key
- 211 Sleeve Key
- 212 Coupling Key
- 300 Stud
- 320 Screw
- 400 Soft Packing
- *405 Mechanical Seal
- 420 O-ring
- 422 O-ring
- 600 Electrical Motor

(*) Optional

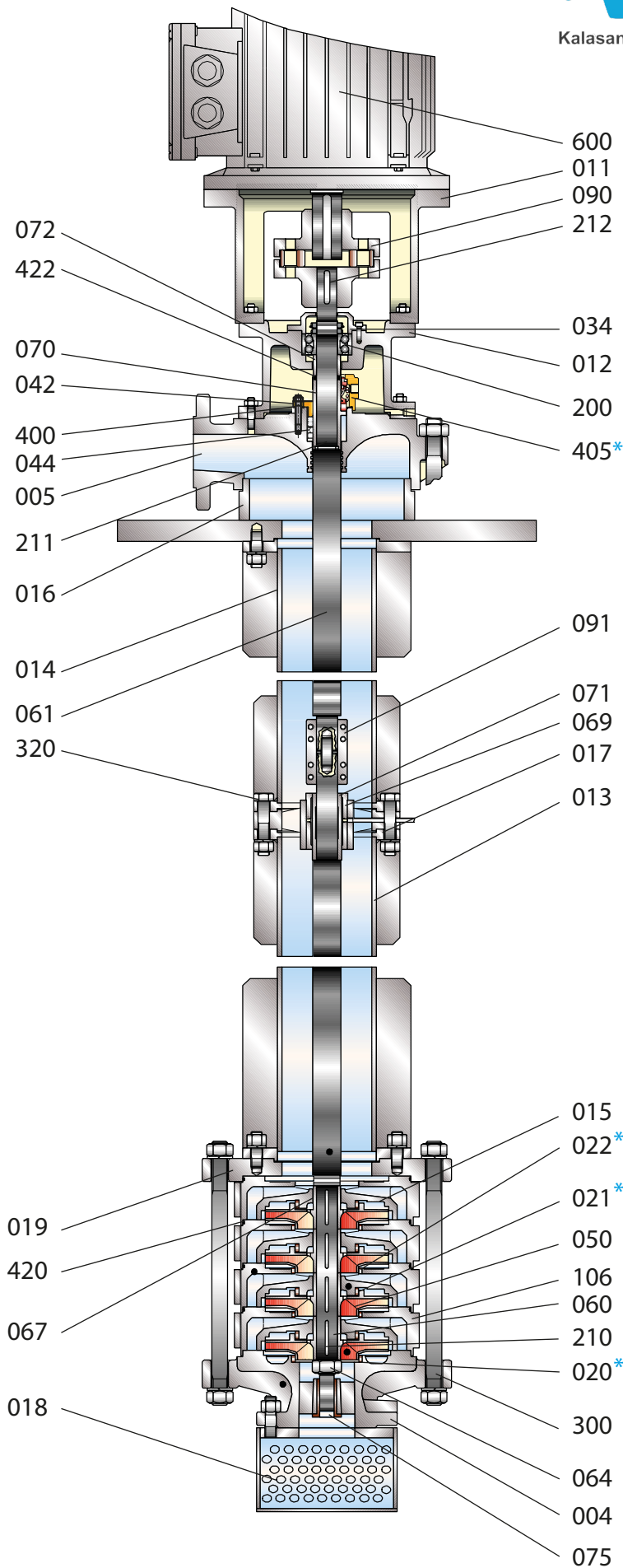



Kalasanati.com

SKM-EVK

Technical Data

Part List	0.6025	0.7040	1.0619	1.4308	1.4309	1.4408	1.4409	1.4500	1.4517	1.4469	1.4317	1.4008	2.1050.01	2.0975.01	2.1096.01	1.0037	1.0503	1.4021	1.4021+QT	1.4301	1.4404	1.4460	1.4462	Tungsten Carbide	
Suction Casing	●	○		○	○	○	○	○	○	○	○	○	○												
Discharge Casing	●	○		○	○	○	○	○	○	○	○	○	○												
Stage Casing	●	○		○	○	○	○	○	○	○	○	○	○												
Diffuser	●	○	○	○	○	○	○	○	○	○	○	○	○												
Impeller	●	○	○	○	○	○	○	○	○	○	○	○	○	○	○								○		
Shaft																	●	○	○	○	○			○	
Bearing Housing	●	○	○	○	○	○	○																		
Wear Ring	○	○	○	○	○	○	○	○	○	○	○	○	○	○	○										
Spacer Sleeve																	●	○	○	○	○			○	
Shaft Protecting Sleeve																	●	○	○	○	○			○	
Interstage Sleeve																	●	○	○	○	○			○	
Sleeve Bearing													●												○
Column Pipe																●				○	○				
Mechanical Seal (*)	EN 12756																								

● Standard manufacturing
○ Optional

Material Equivalents

Description	DIN / EN		AISI / SAE / ASTM
Cast Iron	0.6025	EN-GJL-250 (GG25)	A48 Class 40B
Nodular Cast Iron	0.7040	EN-GJS-400-15 (GGG40)	A536 60-40-18
Nodular Cast Iron	0.7043	EN-GJS-400-18-LT (GGG40.3)	A536 60-40-18
Cast Steel	1.0619	GP240GHGS-C25	A216 WCB
Chrome Nickel Cast Steel	1.4308	GX5CrNi19-10	A351 CF8
Chrome Nickel Cast Steel (low carbon)	1.4309	GX2CrNi19-11	A351 CF3
Chrome Nickel Molybdenum Cast Steel	1.4408	GX5CrNiMo19-11-2	A351 CF8M
Chrome Nickel Molybdenum Cast Steel (low carbon)	1.4409	GX2CrNiMo19-11-2	A351 CF3M
Austenitic Cast Steel	1.4500	GX7NiCrMoCuNb25-20	A351 CN7M
Austenitic - Ferritic Cast Steel (duplex)	1.4517	GX2CrNiMoCuN25-6-3-3	A890 CD4MCuN
Austenitic - Ferritic Cast Steel (super duplex)	1.4469	GX2CrNiMoN26-7-4	A890 CE3MN
Martenzitic Stainless Cast Steel	1.4317	GX4CrNi13-4	A352 CA6NM
Martenzitic Stainless Cast Steel	1.4008	GX7CrNiMo12-1	A217 C9A15
Cast Bronze (tin alloy)	2.1050.01	G-CuSn10	B427 C90700
Cast Bronze (nickel alloy)	2.0975.01	G-CuAl10Ni	B148 C95500
Cast Bronze (lead)	2.1096.01	G-CuSn5ZnPb	B584 C83600
Carbon Steel	1.0503	C45	AISI 1045
Chrome Steel	1.4021	X20Cr13	A276 Type 420
Chrome Steel (heat treated)	1.4021	X20Cr13	A276 Type 420+QT
Chrome Nickel Steel	1.4301	X5CrNi18-10	A276 Type 304
Chrome Nickel Steel (low carbon)	1.4404	X2CrNiMo17-12-2	A276 Type 316L
Duplex (austenitic-ferritic) Steel	1.4460	X3CrNiMoN27-5-2	AISI 329
Duplex (austenitic-ferritic) Steel	1.4462	X2CrNiMoN22-5-3	UNS S32205

Flange Dimensions

DNe/DNb	Suction & Discharge (PN 16)				Suction & Discharge (PN 40)			
	Df	k	s	n	Df	k	s	n
40	150	110	19	4	150	110	19	4
50	165	125	19	4	165	125	19	4
65	185	145	19	4	185	145	19	8
80	200	160	19	8	200	160	19	8
100	220	180	19	8	235	190	23	8
125	250	210	19	8	270	220	28	8
150	285	240	23	8	300	250	28	8
200	340	295	23	12	375	320	31	12

“ n “ number of holes

SMV

Vertical Shaft Turbine Pump



Handled Liquids

Clean or contaminated lake waters, rivers, dam waters, untreated industrial waters and liquids with fibrous and solid substances.

Technical Data

Discharge Flange _____ up to 1000 mm

Capacity _____ up to 8000 m³/h

Head _____ up to 250 m

Speed _____ up to 1450 rpm

Operating Temperature _____ up to + 80 °C

Design Features

- Single or multi stage mixed flow pumps.
- It usually consists of group of stages, columns and discharge caps.
- Flow capacity is between 300 – 8000 m³/h and head is up to 250m. Custom manufacturing is needed for larger capacities.
- They are usually mounted vertically.
- There are no suction problems at first motion since stages are in contact with fluid.
- High efficiency and low operating costs.
- Mounting and demounting are easier with flanged column pipes.
- Enclosed or semi-open impeller is used.

Pump Designation

SMV 16 B - 3

Pump Type _____

External Diameter of Stage _____

Impeller Type _____

Number of Stages _____



- It can be lubricated with handled liquids or grease. It also can be lubricated with clean water or oils by customer request.

- Discharge head can be placed above ground or underground.

- VHS or V1 electric motor can be used.

- Bronze or rubber intermediate bearing can be selected.

Shaft Sealing

- Depending on type of the fluid and operating conditions, soft seal, single, double or cartridge type mechanical seal is used.



Kalasanati.com

Field Chart

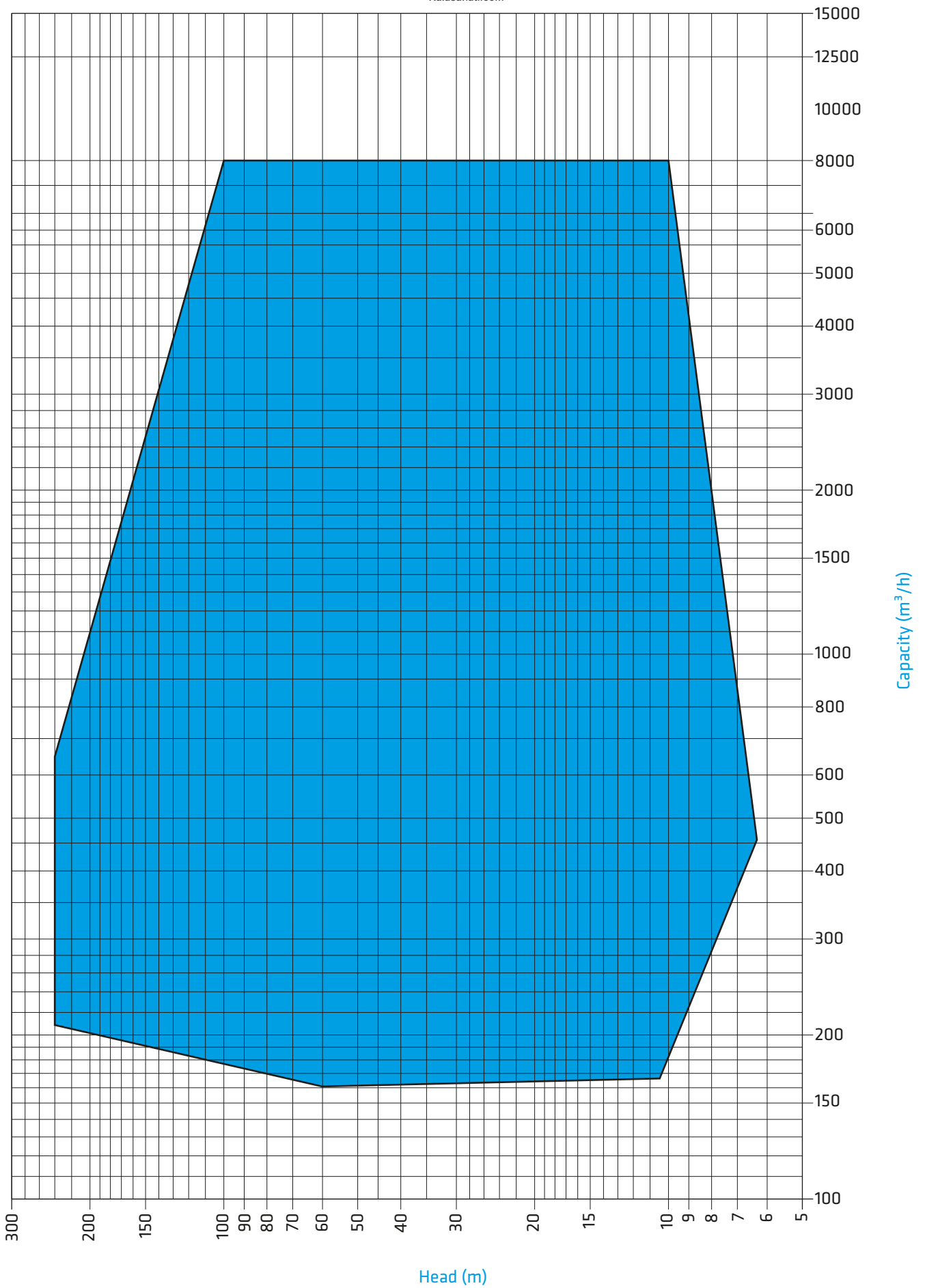

Sectional Drawings



Kalasanati.com

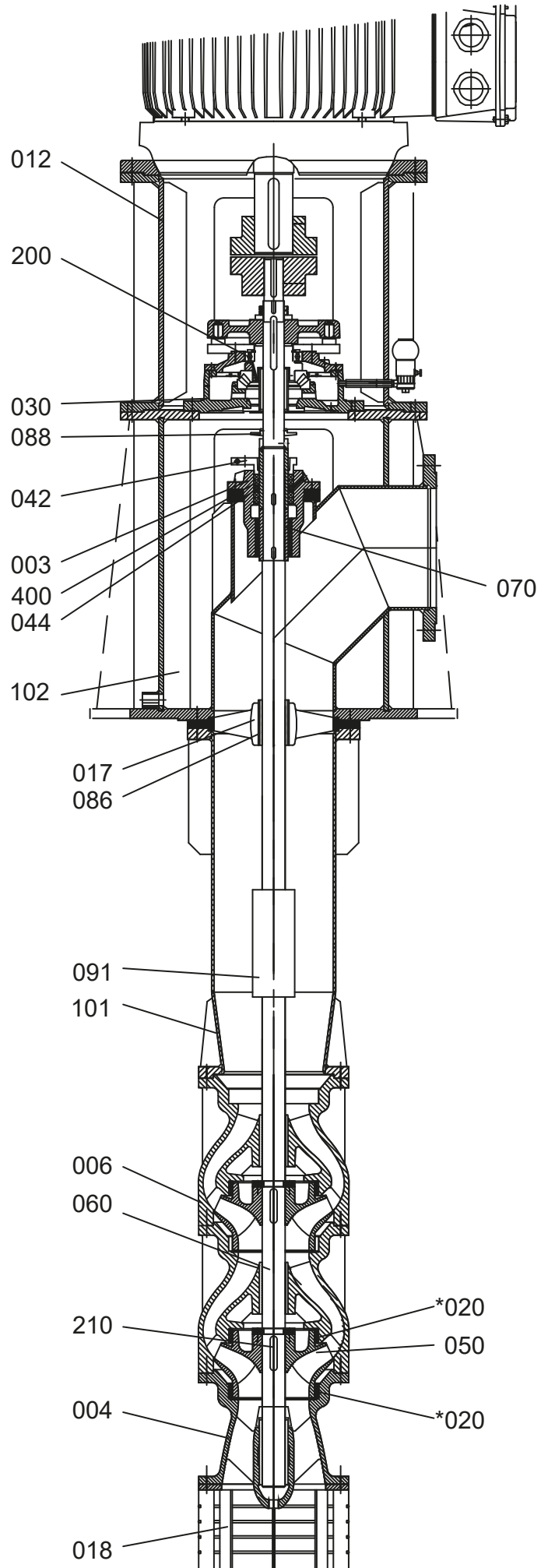

Part List

003	Stuffing Box
004	Suction Bell
006	Stage
012	Motor Pedestal
017	Intermediate Bearing Housing
018	Filter
020	Wear Ring
030	Thrust Bearing Housing
042	Gland
044	Lantern Ring
050	Impeller
060	Shaft
070	Shaft Sleeve
086	Intermediate Bearing
088	Thrower
091	Coupling
101	Column Pipe
102	Discharge Head
200	Bearing
210	Key
400	Soft Packing



Types of Discharge Head

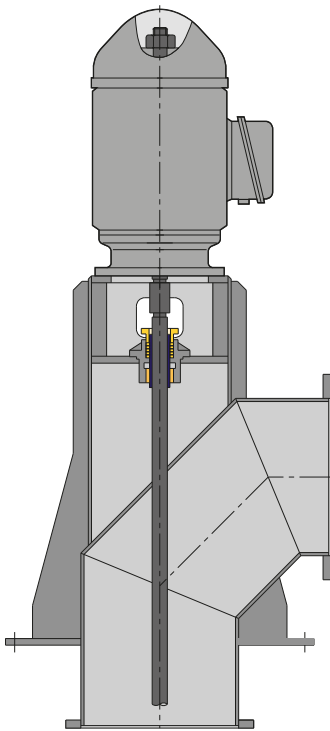

Above ground
VHS electric
motor

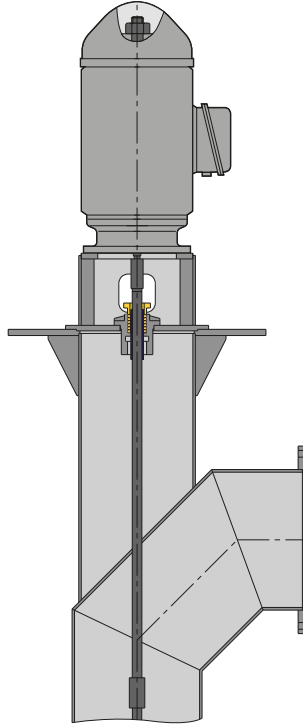

Underground
VHS electric
motor

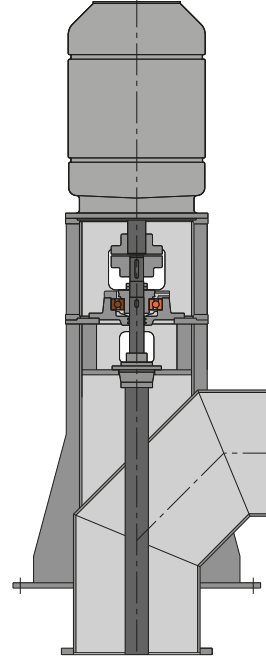

Above Ground
Thrust Bearing
V1 electric motor

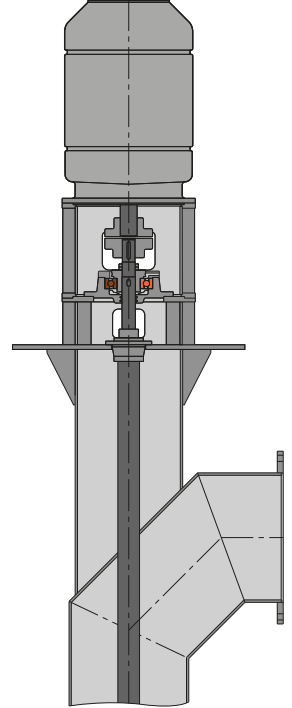

Underground
Thrust Bearing
V1 electric motor

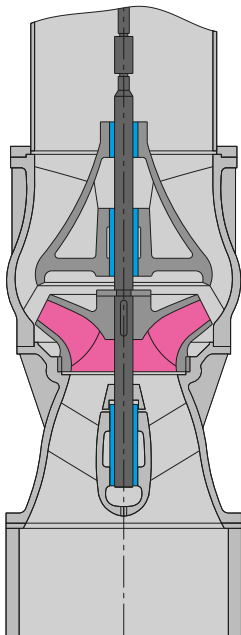

Stage group of mixed
flow pump

Column Bearing Housing

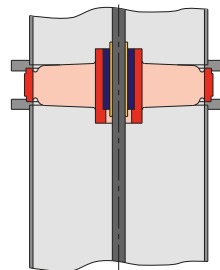

W/L Water
Lubricated

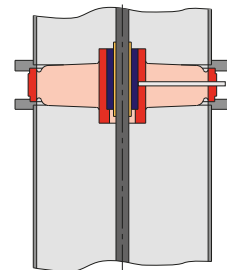

G/L Grease
Lubricated

NMT WET ROTOR CIRCULATION PUMPS



Handled Liquids

In use for pumping clean water or clean water & anti-freeze mixture liquids in heating systems. Water should be according to current quality standards (such as VDI 2035). Liquid should not be contained with abrasive or explosive mixtures, mineral oil, solid or fibrous particles.

Technical Data

	NMT PLUS NMTD PLUS	NMT SMART NMTD SMART	NMT SMART F NMTD SMART F	NMT MAX F NMTD MAX F	NMT LAN F NMTD LAN F
• Connection Dimension	15-25-32	25-32	32-40-50	40-50	40-65-80-100
• Connection type	Screwed	Screwed	Flange	Flange	Flange
• Maximum Capacity (m ³ /h)	5	11	11	37,5	78
• Maximum Head (m)	8	12	10	12	18
• Pressure Class (PN)	10	10	10	6 / 10	6 / 10
• Maximum Power (W)	55	180	180	560	1600
• Voltage (V)	1x230	1x230	1x230	1x230	1x230
• Design Temperature (°C)	+5 / +95	+2 / +110	+2 / +110	+2 / +110	-10 / +110
Material Information					
• Casing	Cast Iron	Cast Iron	Cast Iron	Cast Iron	Cast Iron
• Impeller	Polyamide	PES	PES	PES	S. Steel
• Shaft	Ceramic	S. Steel	S. Steel	S. Steel	S. Steel
• Bearing	Ceramic	Graphite	Graphite	Graphite	Graphite
• Rotor Can	S. Steel	S. Steel	S. Steel	S. Steel	S. Steel

Design Features

- NMT series pumps have variable speed design. Depending on request, they can be supplied as twin type.
- The bearings of the pumps are made of carbon and special hardened steel shaft prevents the wear of the bearings and ensures very quiet operation.
- Good choice for heating systems (Floor Heating – Radiator Heating – Air Conditioning Systems – Solar Systems)
- NMT series pumps, which reduce the electricity consumption to a minimum level, are produced with care as a complete engineering example in terms of efficiency and quality.
- All products (ISO 9001 - CE) are certified and manufactured in European (EU) standards.
- Designed to optimize your energy consumption with features such as variable pressure, constant pressure, constant speed and night mode.
- The full form of ERP regulation is "energy-related products". Purpose of 2009/125 / EC regulation is to reduce energy consumption according to environmental requirements. These environmental requirements are explained in 2013 for EU circulation pumps. From 2013 onwards, this regulation will be practically implemented in the following 2 steps within 7 years.
 - The first phase; EEI max will be 0,23 from 01/08/2015 - Part 2
 - The second phase; EEI max will be 0.23 from 01/01/2020 - Part 2 In this section will cover the replacement of pumps used in heating, ventilation and air conditioning systems.
- Criteria for the best efficient circulators is EEI ≤ 0.20 - Part 2

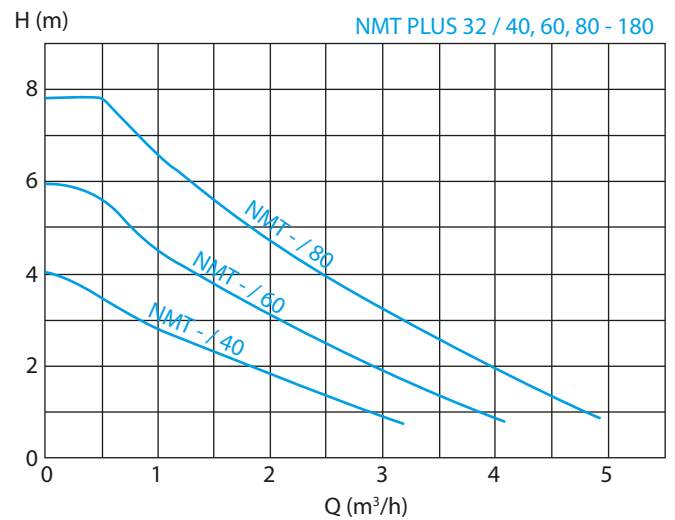
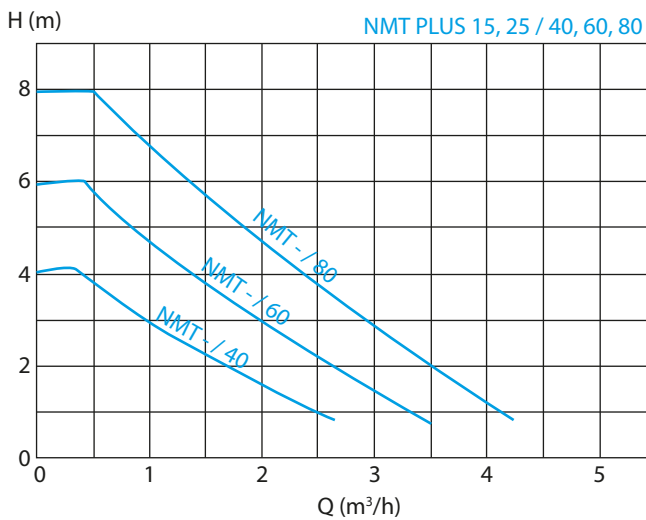

Pump Type	EEl	A (mm)	B	Pmax (w)
NMT PLUS 15/40-130	0,16	130	Rp 1/2	20
NMT PLUS 25/40-130	0,16	130	Rp 1	20
NMT PLUS 15/60-130	0,18	130	Rp 1/2	35
NMT PLUS 25/60-130	0,18	130	Rp 1	35
NMT PLUS 25/80-130	0,21	130	Rp 1	55
NMT PLUS 32/40-180	0,15	180	Rp 1 1/4	20
NMT PLUS 32/60-180	0,17	180	Rp 1 1/4	35
NMT PLUS 32/80-180	0,19	180	Rp 1 1/4	55

Pump Type	EEl	A (mm)	B	Pmax (w)
NMTD PLUS 25/60-180	0,17	180	Rp 1	2x35
NMTD PLUS 25/80-180	0,19	180	Rp 1	2x55

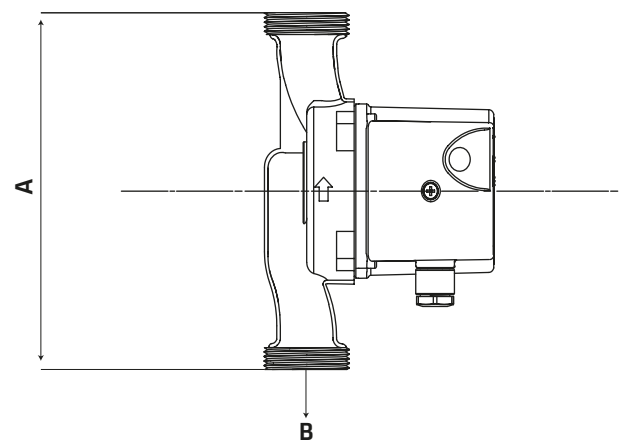

Pump Designation

NMT D PLUS 25 / 60 - 130

Twin Type _____

Pump Type _____

Suction and Discharge Nozzle (DN-mm) _____

Maximum Head x10 _____

Connection Length (mm) _____

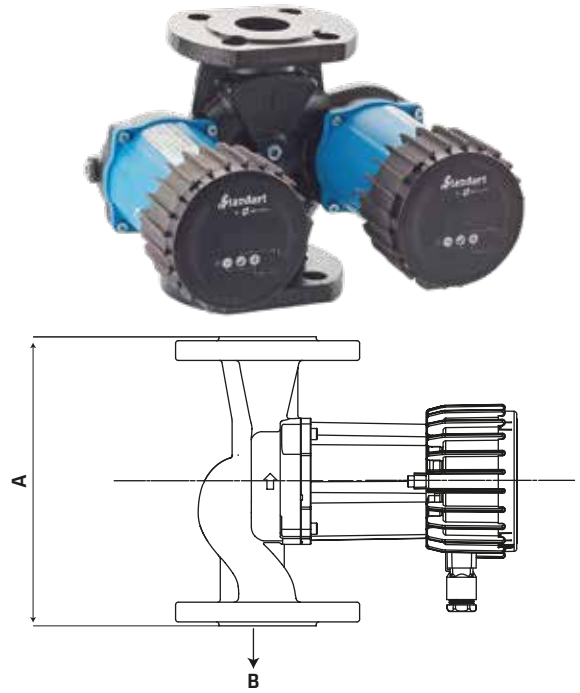
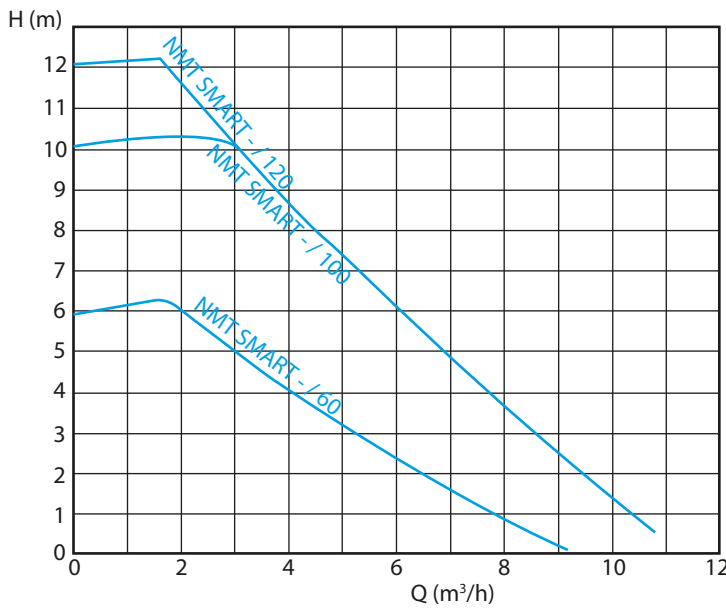

Pump Type	EEl	A (mm)	B	Pmax (w)
NMT SMART 25/60-180	≤ 0,21	180	Rp 1	90
NMT SMART 25/100-180	≤ 0,21	180	Rp 1	180
NMT SMART 32/60-180	≤ 0,21	180	Rp 1¼	90
NMT SMART 32/100-180	≤ 0,21	180	Rp 1¼	180
NMT SMART 32/120-180	≤ 0,21	180	Rp 1¼	180

Pump Type	EEl	A (mm)	B	Pmax (w)
NMT SMART 32/60 F	≤ 0,21	220	DN 32	90
NMT SMART 32/100 F	≤ 0,21	220	DN 32	180
NMT SMART 40/60 F	≤ 0,21	220	DN 40	90
NMT SMART 40/100 F	≤ 0,21	220	DN 40	180
NMT SMART 50/100 F	≤ 0,21	240	DN 50	180

Pump Type	EEl	A (mm)	B	Pmax (w)
NMTD SMART 32/60-180	≤ 0,21	180	Rp 1¼	2x90
NMTD SMART 32/100-180	≤ 0,21	180	Rp 1¼	2x180

Pump Type	EEl	A (mm)	B	Pmax (w)
NMTD SMART 40/60 F	≤ 0,21	220	DN 40	2x90
NMTD SMART 40/100 F	≤ 0,21	220	DN 40	2x180

Communication

(*)Smart C : Ethernet, Modbus RTU, Analog control input 0-10 V, 3 Analog input / output, 1 relay output

Pump Designation

NMT D SMART C 25 / 60 - 180 F

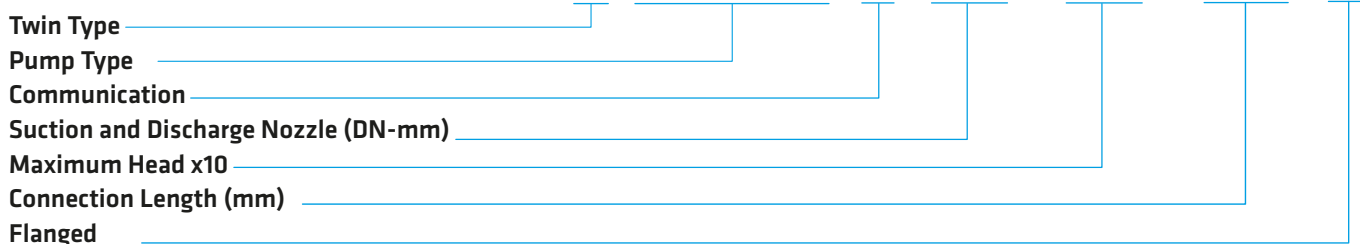

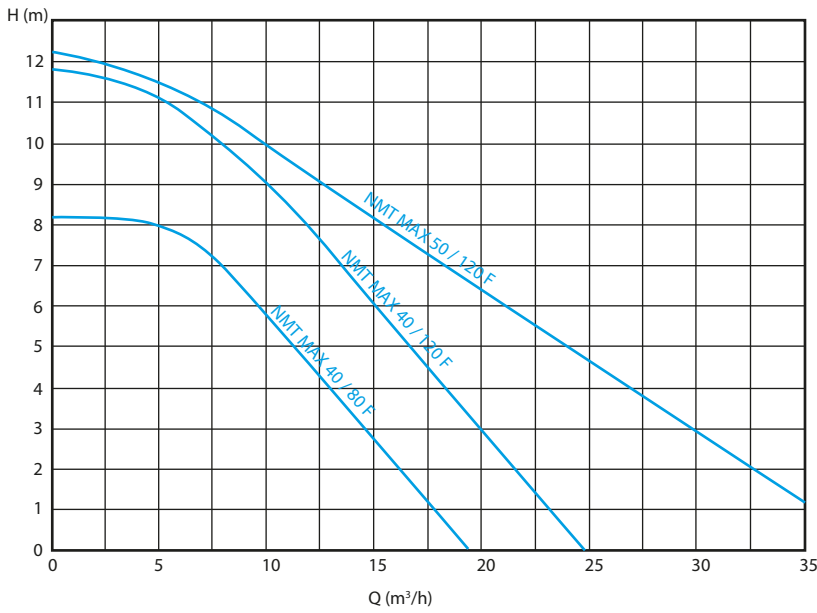

Kalasanati.com

Pump Type	EEl	A (mm)	B	PN	Pmax (w)
NMT MAX 40/80 F	≤ 0,21	250	DN 40	6/10	270
NMT MAX 40/120 F	≤ 0,21	250	DN 40	6/10	480
NMT MAX 50/120 F	≤ 0,21	280	DN 50	6/10	560

Pump Type	EEl	A (mm)	B	PN	Pmax (w)
NMTD MAX 40/120 F	≤ 0,21	250	DN 40	6/10	2x480
NMTD MAX 50/120 F	≤ 0,21	280	DN 50	6/10	2x560

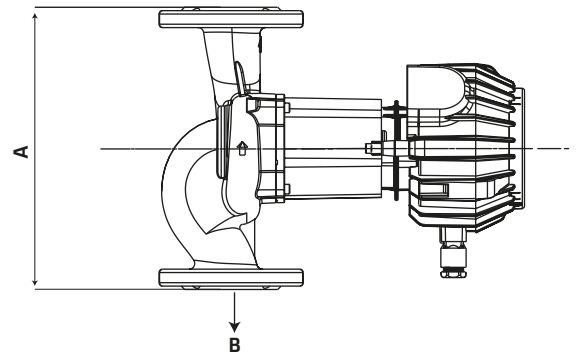

Communication

(*)Max C : Ethernet, Modbus RTU, Analog control input 0-10 V, 3 Analog input / output, 1 relay output

Pump Designation

NMT D MAX C 40 / 80 F

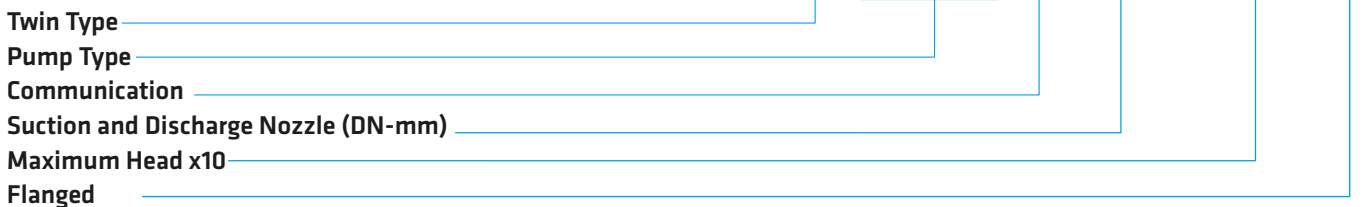

NMT LAN



Kalasanati.com

NMT

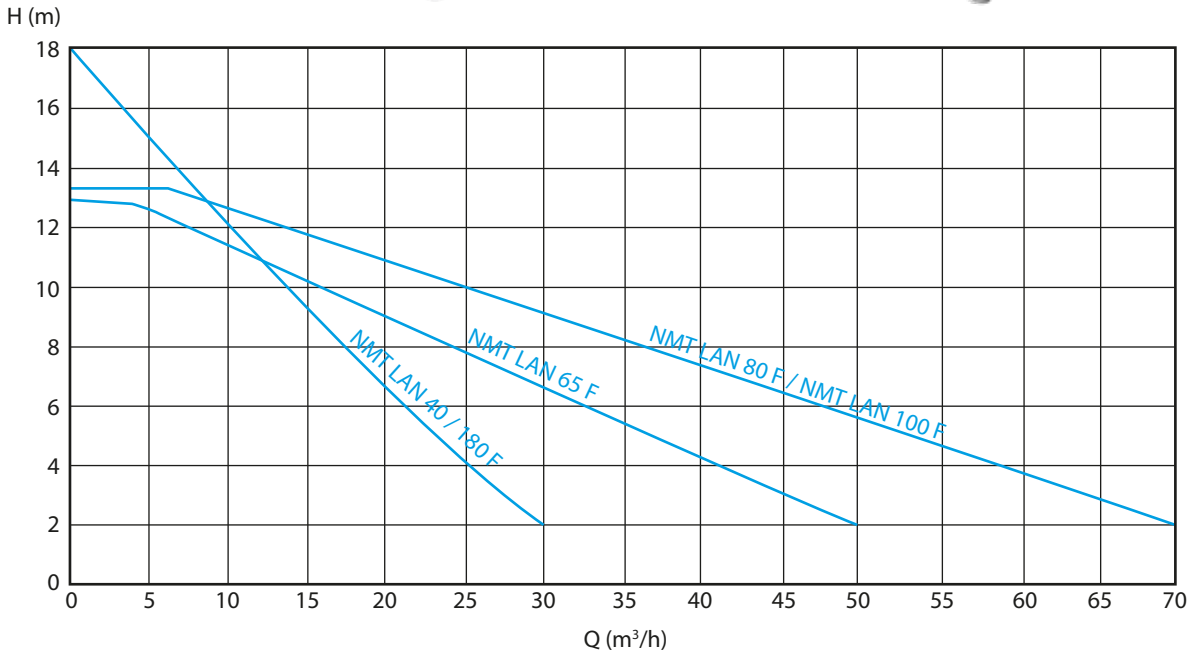

Pump Type	EEl	A (mm)	B	PN	Pmax (w)
NMT LAN 40/180 F	≤ 0,23	250	DN 40	6/10	950
NMT LAN 65 F	≤ 0,23	340	DN 65	6/10	1100
NMT LAN 80 F	≤ 0,23	360	DN 80	10	1600
NMT LAN 100 F	≤ 0,23	360	DN 100	10	1600

Pump Type	EEl	A (mm)	B	PN	Pmax (w)
NMTD LAN 65 F	≤ 0,23	340	DN 65	6/10	2x1100
NMTD LAN 80 F	≤ 0,23	360	DN 80	10	2x1600

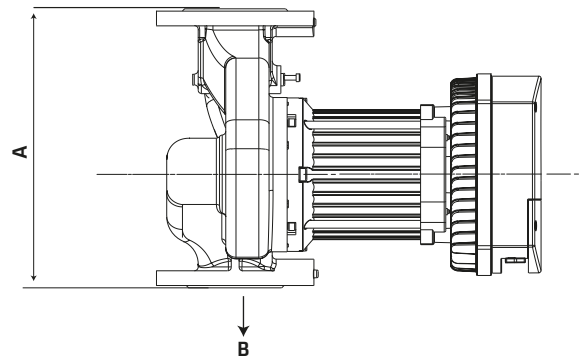

Communication

Lan : Ethernet

(*)Lan C : Ethernet, Modbus RTU, Analog control input 0-10 V, 3 Analog input / output, 1 relay output

Pump Designation

NMT D LAN C 40 / 180 F

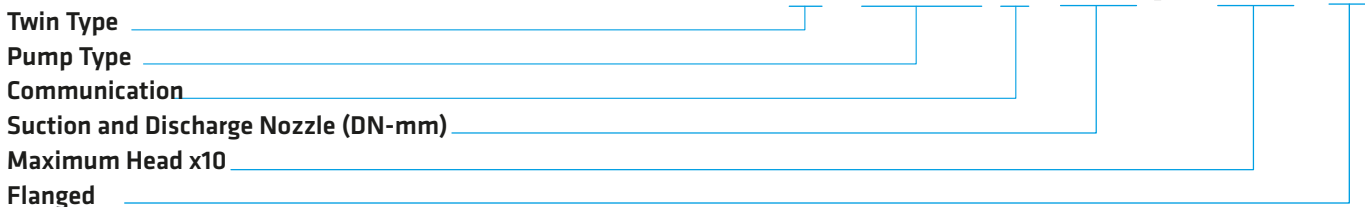



Kalasanati.com

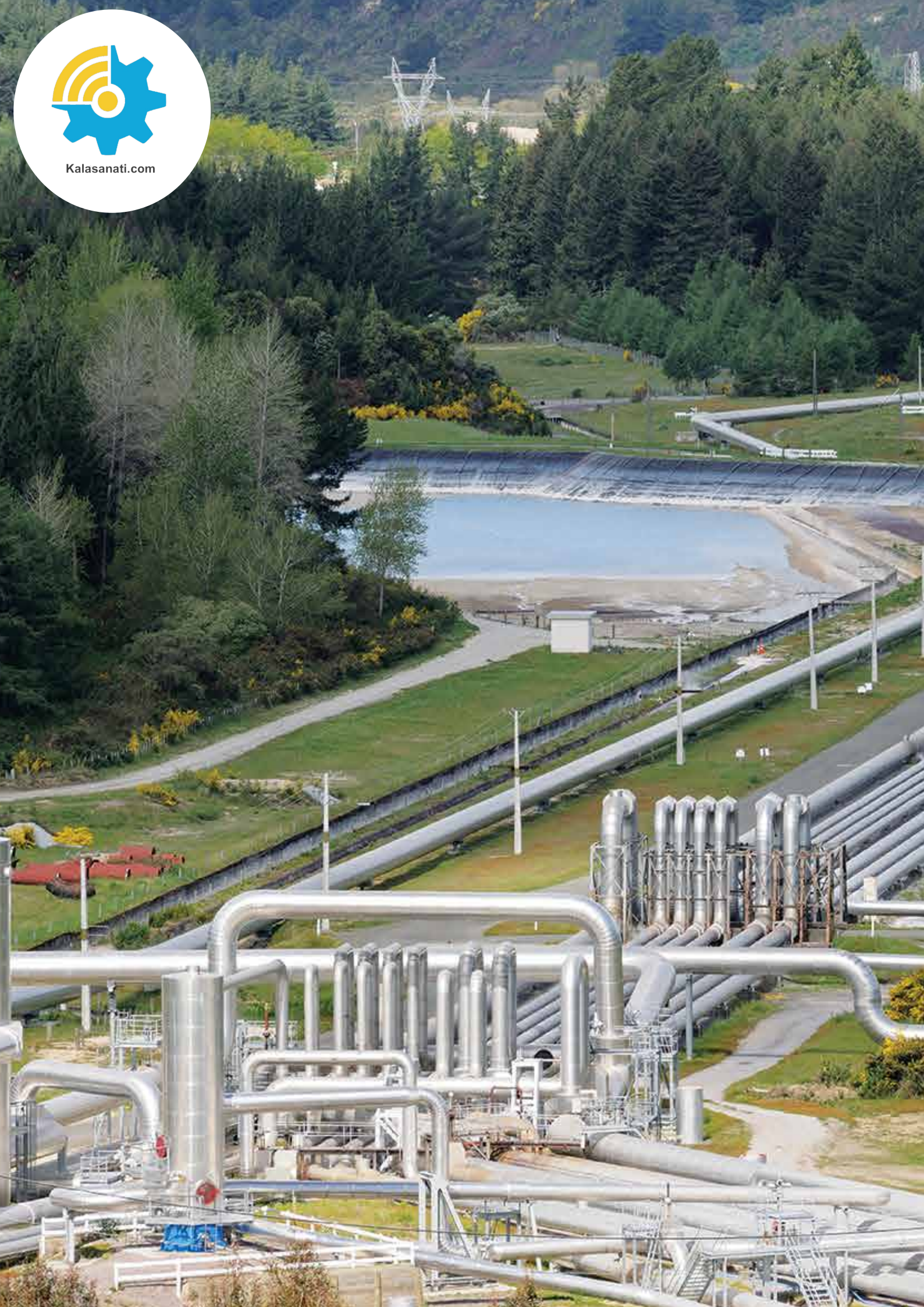



Kalasanati.com

Hydropower: End Suction Norm



Hydropower / NT

- Horizontal radially split volute casing type, single stage, end suction, pump as turbine systems with closed impeller.
- Designed to work in between 100- 1800 m³/h capacities with 10-120 m net heads.



Hydropower / NT - V

- Vertical radially split volute casing type, single stage, end suction, pump as turbine systems with closed impeller.
- Designed to work in between 100- 1800 m³/h capacities with 10-120 m net heads.

Hydropower: Multistage



Hydropower / KM

- Horizontal ring section, multi stage, pump as turbine systems with closed impeller and diffuser.
- Designed to work in between 30- 500 m³/h capacities with 10-250 m net heads.



Hydropower / KM - V

- Vertical ring section, multi stage, pump as turbine systems with closed impeller and diffuser.
- Designed to work in between 30- 500 m³/h capacities with 10-250 m net heads.

Hydropower: Double Suction



Hydropower / DS

- Horizontal radially, axial split case, single stage, double suction pump as turbine systems.
- Designed to work in between 150- 4000 m³/h capacities with 20-150 m net heads.



Hydropower / DS - V

- Vertical radially, axial split case, single stage, double suction pump as turbine systems.
- Designed to work in between 150- 4000 m³/h capacities with 20-150 m net heads.



Kalasanati.com

Field Chart

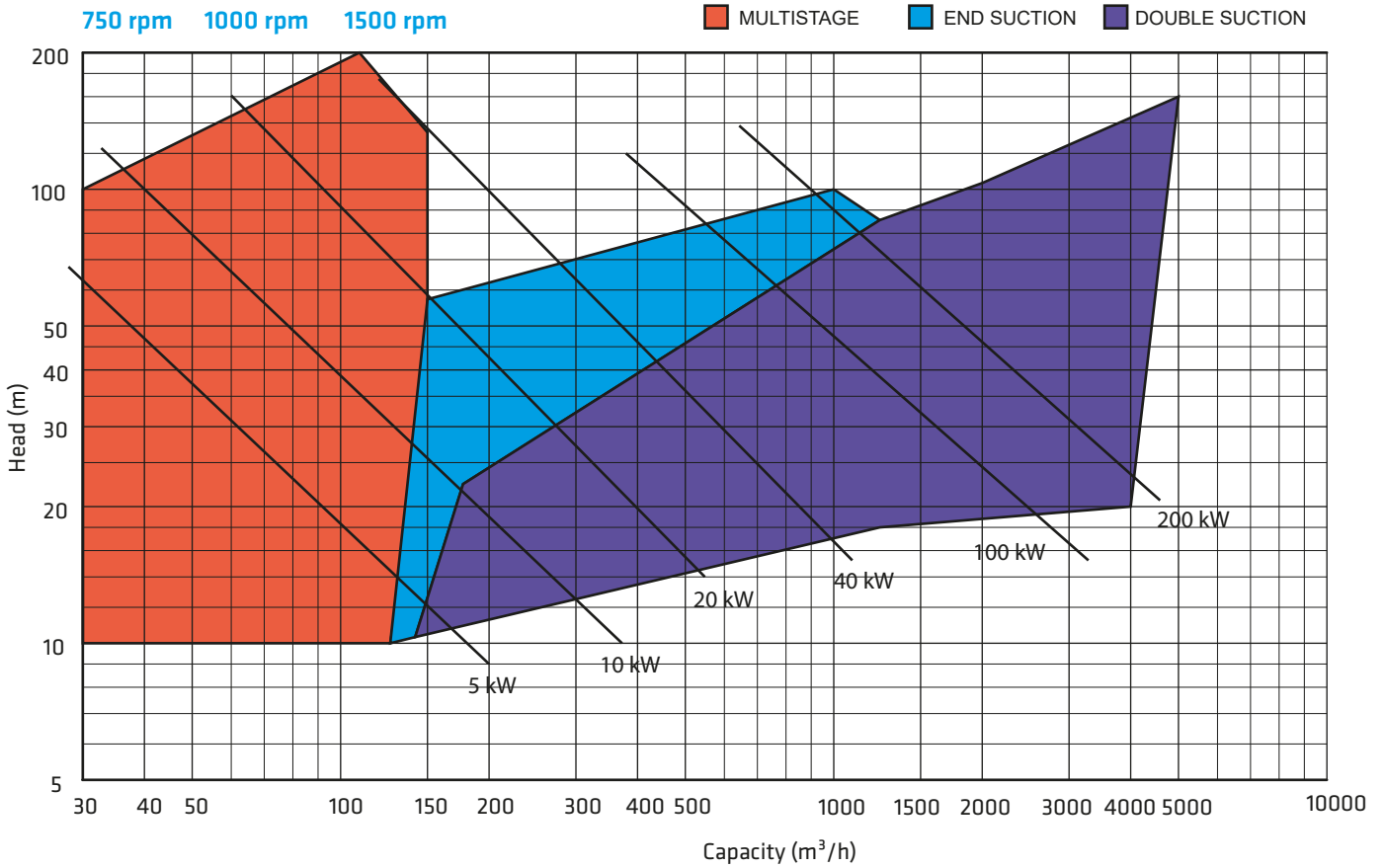

For more capacity, head or power requirements, please get in contact with our company via our web site.

Electric Generation for Isolated (Off-grid) Areas

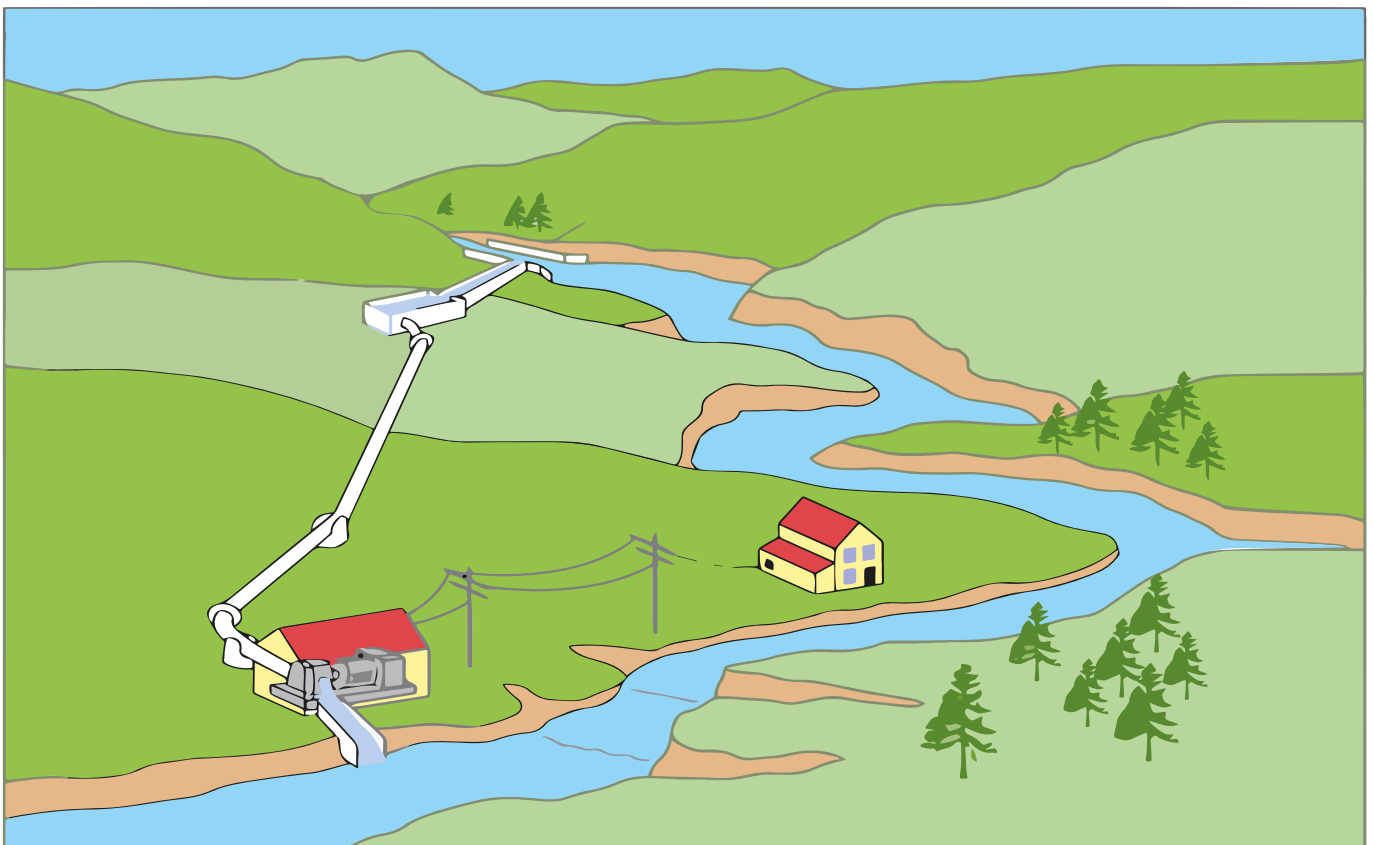



Generation of Electricity for Drinking Water Needs in off/on-grid regions:

There are so many alternative ways in the market and regulation due to pressure is one of the best ways of controlling losses regarding to resources in literature. To regulate pressure, atmospheric tanks and pressure regulating valves (PRV) can be alternatively used. Since, PRV needs extra investments and underutilizes the broken energy, it will not be a wise option to choose. Instead, it would be better to utilize the idle energy and re-generate it with either hydraulic turbines or pump as turbines, which we call “Hydropower” systems. Standart “Hydropower” series pump as turbines, provide both energy savings and efficient water loss controls where energy is broken in the systems.

Hydropower Installation for a Typical City Drinking Water Piping System

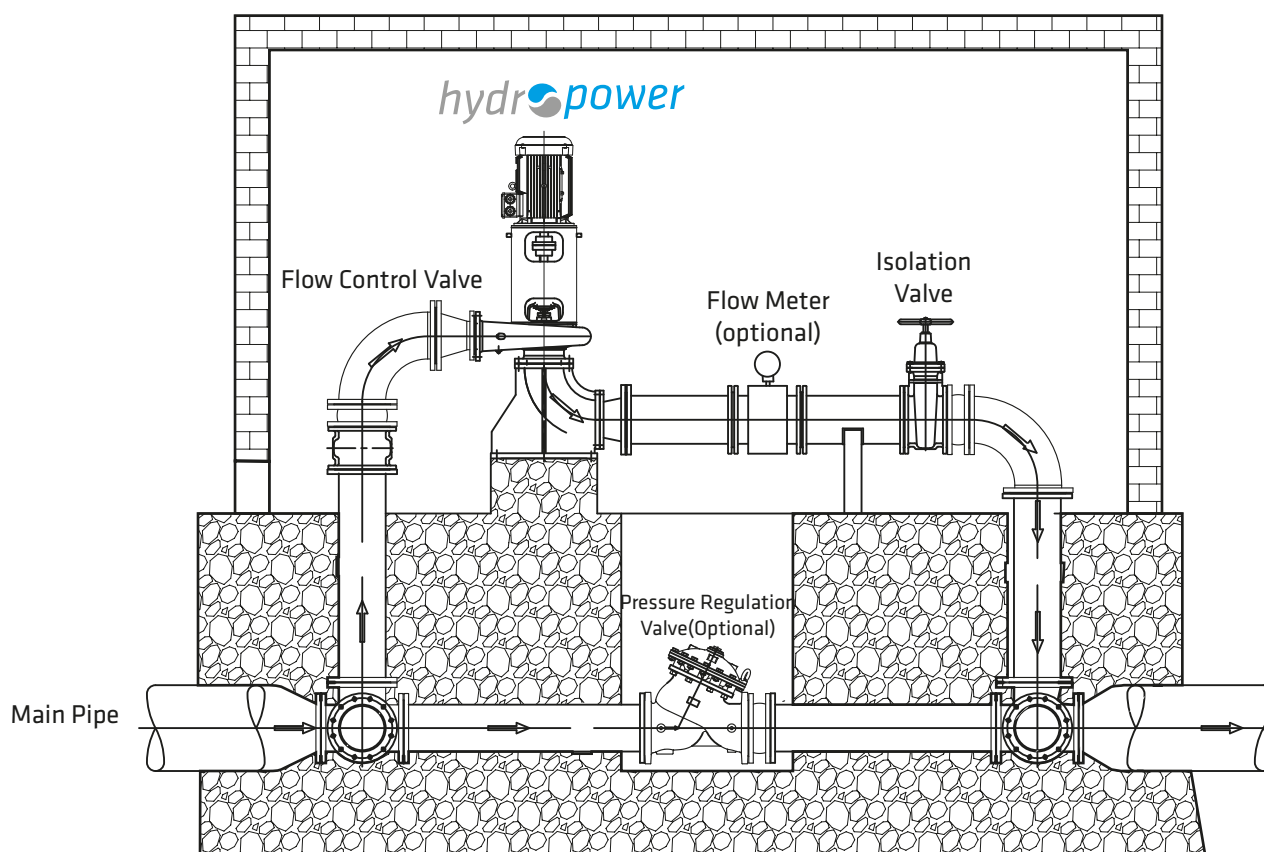

Pump as Turbine Projects

In order to calculate the needs, annual water capacity and head requirements should be known by our customers. With these statistical inputs, optimum systems can be designed.

In order to use Pumps as Turbine following issues should be covered:

- Since capacities in pump as turbines at best efficient points would be more than stand alone pumps, the mechanical stress should be carefully considered in these systems.
- Rotating items shouldn't be harmed or discharged while rotating in opposite direction.
- Turbine should not run away during the bypass of excessive water.
- Extra precautions should be taken for cavitation and water hammer risks.
- System should be adoptable to new conditions according to changes in capacities and heads.
- It is generally a good option to use hydropower in parallel forms to maximize the outputs. This rule is eligible for both on-grid and off-grid regions.



Kalasanati.com

GENERAL INFORMATION ABOUT BOOSTER PUMPS

What is booster pump ?

The pressurization systems which takes low pressured water from a tank or directly from city network and provide it with required flow rate and pressure are called booster pumps. Their operations are completely automatic according to intended use.

Depending on the intended use, boosters are generally classified as follows;

- Domestic Water Booster Pumps
- Irrigation System Booster Pumps
- Process Water Booster pumps

According to which Standarts booster pumps should be selected ?

Until today, in Europe, widely accepted standart which describes pressurization systems comprehensively is DIN 1988. Domestic water booster pumps are defined in DIN 1988-5, how and under what conditions they are selected and used are described.

The European Union EN 806 standard is valid in the countries of European Union members. However, in some cases it is still being in reference to DIN 1988 norm. Therefore, there is no problem with selections and calculations based on the DIN 1988 standard. Selection and calculation methods in this catalog are taken from DIN 1988-5 and EN 806 standards.

Which parameters should be determined before selecting booster ?

The first condition for long-life booster is selecting according to suitable operating and environmental conditions and determining pump capacities correctly.

In choosing type of booster;

- Positioning of water tank relative to the booster (Does the water come on its own? Or is suction needed?)
- Characteristic of the space where booster will be installed (Is there enough space and air circulation?)
- Correct selection of the number of users and diversity factor
- Properties of the water to be pressurized (hardness, temperature)
- Required head
- Required flow rate and the volume of the expansion tank to be selected

When pump and equipments according to these material and functional characteristics are selected, the right type of booster pump which will be able to work without problems for many years.

How to determine operating pressure range of booster system ?

The pressure in the outlet collector of the booster is the sum of the intake pressure in the inlet collector and the pressure generated by the booster. However, in Turkey boosters are generally supplied from a tank at the same level with the booster and open to atmosphere, so the inlet pressure of the booster is negligible.



While determining operating pressure of booster;

- The static height of the building
- The minimum flow pressure on top floors
- Friction losses in the pipes
- Water meter losses
- Filters and other equipments losses should be calculated.

Minimum pressure of the booster, if there is no special conditions defined by the user, should be approximately 10-15 mwc on the highest settlement or the most critical user

$$H_{bot} = DPe + Pmin\ fl + S (I \times R + DpF) + DPwm + DPap - SPLN$$

(Formula 1)

- H_{bot} : Booster bottom pressure
- DPe : Building height (mWc)
- $Pmin\ fl$: Minimum flow pressure (mWc)
- $S (I \times R + DpF)$: Friction losses in pipes (mWc)
- $DPwm$: Water meter losses (mWc)
- $DPap$: Losses of filter and other equipments if known (mWc)
- $SPLN$: Minimum pressure at the booster inlet (mWc)

SPLN is often neglected in applications that booster is fed from a tank. However on some cases (especially oil filling plants), towers are used as water tanks. On that situation, 15-20 mWc inlet pressure is generated.

Another type of connection is to take water directly from the pressurized network and pressurize it where the network pressure is not enough. If this is the case, inlet pressure must be calculated.

Calculation of total losses in the installation may not always be easy. To do this, it is necessary to know the types, quantities and measurements of any fixtures, valves, pipes and fittings and to calculate the losses in the water flow that will pass through them.

Example of bottom pressure calculation:

- Building Height = 30m
- Minimum flow pressure = 15m
- Total loss of installation = 7,5m
- Water meter loss = 7,5m
- Filter and otlr losses = 0 m
- Inlet pressure = 0 m

Let's calculate bottom pressure value of a booster to be selected for an old apartment

$$H_{bot} = DPe + Pmin\ fl + S (I \times R + DpF) + DPwm + DPap - SPLN$$

$$H_{bot} = 30 + 15 + 7,5 + 7,5 + 0 - 0$$

$$H_{bot} = 60\ mSS$$

The pressure difference called as operating pressure of the booster ($H_{üst}-H_{alt}$) should be as small as possible and the booster should be intended to give a constant pressure. As this value increases, surge pressure in the installation increases and the comfort of use decreases.

Therefore, ($H_{top}-H_{bot}$) 1,5 – 2bar difference as operating range is generally adequate and it is tried to be applied. This difference should not exceed 2.5 bar.

$$H_{top} = H_{bot} + 15\ mWc$$

$$H_{top} = 75\ mWc$$

According to this, our operating pressure is 60-75 mWc.

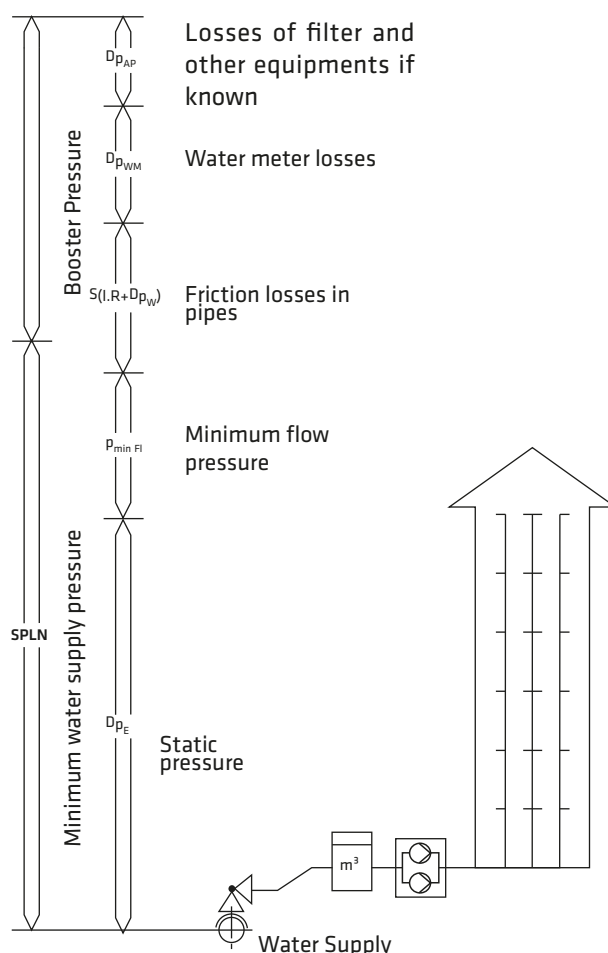

Figure 1

Another point to be aware of when calculating the required pressure to be ensured by the booster is that static water pressure should not exceed 5 bar (50mWc) at any point in the installation.

To ensure comfortable use of water and proper operation of fixtures, DIN 1988 standart requires the use of pressure reducer or zoning the installation (regional pressurization) if the inlet pressure exceeds 5 bar. (figure 2)



Kalasanati.com

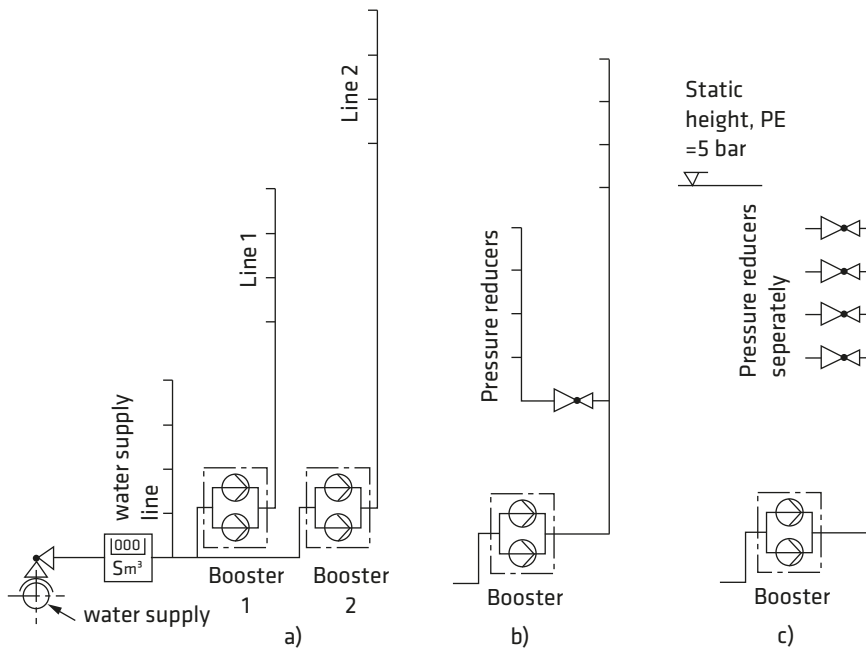

Figure 2

How to determine flow rate of booster system?

Number of flats	Factor of multi-user
4	0,66
5-10	0,45
11-20	0,40
21-50	0,35
51-100	0,30
more than 100	0,25

Table 1

Application Areas	Daily Average. (lt/day)
Corporate housing	150
Luxury housing	200
Luxury Villas	225
Guesthouses	100
Hotels	150
Hospitals	200
Offices	80
Schools	20
Boarding Schools	100
Malls	50

Table 2

Calculation of flow rate has two main criteria. First one is estimated volume of water in unit of time. The other is diversity factor of multi-user systems. We are going to use both criteria when calculating domestic water boosters.

Example of flow rate calculation:

Let's figure out the flow rate of a site where 100 families live in. EN806 standardında belirtilen formüle göre;

$$Q = \frac{A \times B \times T \times f}{1000} \quad (\text{Formula 2})$$

- Q = Booster flow rate (m^3/h)
- A = Number of flats
- B = Number of individuals in the family
- T = Daily average water consumption of the individual (liter /day)
- f = Diversity factor

We may take the number of individuals as 4-5 per average family in Turkey. We will use Table 1 for diversity factor and Table 2 for Daily average water consumption. According to this;

$$Q = \frac{100 \times 4 \times 150 \times 0,30}{1000} = 18 \text{ m}^3/h$$

According to this result, we can select a single pump booster that provides 18 m³/h flow rate. However, as in the above example, it is more accurate to select multiple pump boosters in crowded places such as hospitals.

According to DIN standards pumps must be selected with backups. While the selected spare pump is not working, other operating pumps total flow rate should be equal to our calculated booster flow rate, which is 18 m³/h

According to this;

- 2x 18 m³/h or
- 3x 9 m³/h or
- 4x 6 m³/h might be selected

CALCULATION AND SELECTION METHODS OF MEMBRANE EXPANSION/PRESSURED TANKS

Small volume membrane expansion tanks in booster sets, according to producers preference, are used from several liters to 5000 liter capacities. Membrane expansion tanks are produced in various types and capacities such as vertical, horizontal, footed and non-footed. Nowadays, the use of expansion tanks that have membrane made out of Butyl, EPDM or natural rubber separation for water and gas parts has become widespread.

When these tanks are not used or for example their membranes are exploded, irregularities occur in booster's start/stop functions and that causes operation difficulties.

The purpose of using membrane tanks connected to the discharge lines of booster sets is limiting number of switches of booster pumps.

Electric motor manufacturers switch number recommendation is around S=20-30 / hour. That means, more than 20-30 times of start/stop in an hour for motors is not recommended. Continuous start/stop function not only shortens the service life of electrical motor, pump parts and electrical panel equipments but also increases electrical energy consumption due to starting current. Therefore, especially for motors bigger than 3kW, it is advisable to limit switch number.

Absorbing possible system shocks, keeping the pressurized water in a certain amount as a reserve in short power cuts are other purposes of the use of these tanks.

In section 5 of DIN 1988 standard estimated volume calculation for membrane expansion tanks is developed based on calculation of pressure controlled air cushioned expansion tank in DIN 4810 standard.

Accordingly, the nominal volume of the expansion tank to be selected is calculated according to the Formule 3.

$$VE = 0,33 \times V_{max} \frac{H_{top} + 1}{(H_{top} - H_{bot}) \times S}$$

(Formula 3)

- VE : Nominal volume of selected tank (liter)
- V_{max} : Flow rate of a pump at H bottom pressure (m³/hour)
- H_{top} : Booster's set top pressure (bar)
- (H_{top} - H_{bot}) : Booster's set operating pressure difference (bar)
- S : Required number of switch (1/ hour)



Kalasanati.com

Example of membrane nominal volume calculation

In an example, the booster set wick has H_{alt} equals to 45 mSS, H_{üst} equals to 65 mSS and 44 m³/hour are given. Also the number of pump in booster set is four wick are working rotatory. The required number of switch is given 30/hour.

- V_{max} = 44 / 4 = 11 m³/saat (maximum flow rate of a pump)
- H_{top} = 6,5 bar
- H_{bot} = 4,5 bar
- S = 30 / hour

The nominal volume of required membrane expansion tank (VE)

$$VE = 0,33 \times 11 \frac{6,5 + 1}{(6,5 - 4,5) \times 30} = 0,453 \text{ m}^3 = 453 \text{ lt}$$

The nominal volume of the tank is 500 liters. In the operating conditions of this tank, the useful water volume (VF)

$$VF = VE \frac{H_{top} - H_{bot}}{H_{top} + 1} \quad \text{(Formula 4)}$$

$$VF = 500 \frac{6,5 - 4,5}{6,5 + 1} = 133 \text{ liters are calculated.}$$

Another criteria in membrane expansion tank selection is pressure class that tank should have.

The zero flow rate pressures of the pumps used in boosters are determining the pressure class of the tank. Tank nominal operating pressure should be higher than zero flow rate pressures of pumps.

The pre-air pressure of the tank is dependent of operating conditions and should be set to a value that 10% lower than the H_{bot} operating pressure.

In the above example booster application with $H_{bot} = 45$ mWc, pre-gas pressure of required membrane expansion tank should be set to approximately 40 mWc = 4 bar.

There are varios methods of connecting membrane tanks to the booster's discharge line. Generally, one side of the pressure collector connects to the tank and the other side to the installation. It is also possible to connect the tank to anywhere on building's installation line.

Important point of making connections is that the connections can be quickly detached for membrane change or equivalent situation and can be isolated from installation by using an additional valve.

ACCORDING TO PUMP TYPES RECOMMENDED MINIMUM TANK VOLUMES			
SB M/T 80 PUMPS	100 lt.	CDLF 4 PUMPS	200 lt.
SB M/T 90 PUMPS	200 lt.	CDLF 8 PUMPS	300 lt.
SB M/T 100 PUMPS	300 lt.	CDLF 12 PUMPS	500 lt.
GRV VD PUMPS	200 lt.	CDLF 16 PUMPS	500 lt.
GRV VB PUMPS	300 lt.	CDLF 20 PUMPS	750 lt.
SKMV 32 PUMPS	500 lt.	CDLF 32 PUMPS	750 lt.
SKMV 40 PUMPS	750 lt.	CDLF 42 PUMPS	1000 lt.
SKMV 50 PUMPS	1000 lt.	CDLF 65 PUMPS	2x1000 lt.
SKMV 65 PUMPS	2x1000 lt.	CDLF 85 PUMPS	2x1500 lt.

Table 3

INSTALLATION OF BOOSTERS

Boosters can operate connected to a tank or directly to city network. (Figure 3)

For directly connected to city network boosters, it is precondition that inlet pressure is not surging more than 1 bar and is not lower than 0,5 bar. In networks with unfulfilled regarding conditions, it is not true to connect the booster directly to the city network. Due to inadequacy in network pressures, this system is rarely used in Turkey.

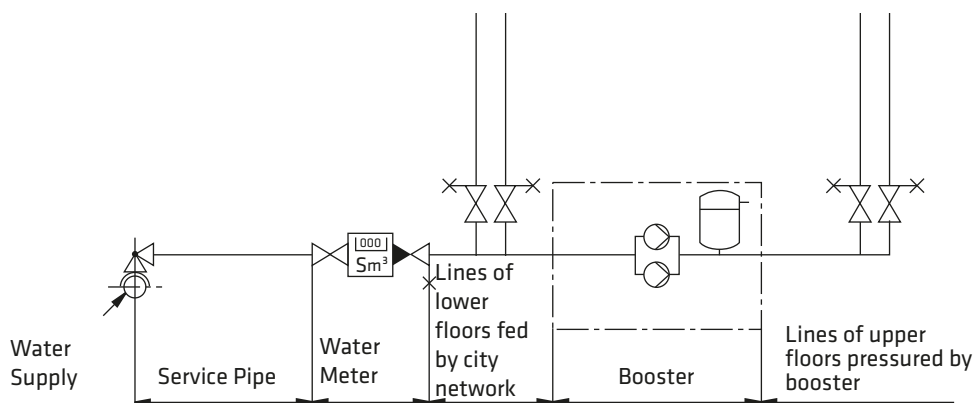

Kalasanati.com

In a booster system that operates by taking water from a tank, the water must be able to flow towards the pump by its own weight and a pre-pressure of about 0.2 bar must be generated at the suction port of the pump.

Operation of the booster by suction is actually not correct. However, when this is forced to, the installation should be designed using a pipe whose internal diameter is at least one diameter wider than the suction mouth of the pump. From the shortest possible path, the installation should be determined using the least amount of elbow and fittings. Valve diameter should be kept as large as possible. It is mandatory that each pump has a separate suction line.

Control Panel Options

Two types of panels are used as standard in boosters.

- The first is pressure switch controlled electrical panels. These panels are run/stopped according to pressure signal received from each pump's separated pressure switches. In this type panel boosters, sufficient volume of expansion tank is used for minimizing number of switches.
- The second is frequency controlled electrical panels. Comfort is important in regarding facilities using these panels. Pressure information received from Transmitter is run on the frequency inverter's PFC macro or PLC and keeps the line pressure constant by reducing the pump's rate according to system flow rate. In this type of panel booster, an expansion tank with a lower volume than the first type is used.

Pressure Switch Controlled Panel Properties

- Works with 380-460 V AC 50 Hz / 60 Hz mains voltage.
- Panel frame is made of thermoplastic material with IP 54 protection class or manufactured from DKP sheet and painted with RAL 7032 electrostatic paint.
- Panels have Manuel - 0 - Automatic selector switch.
- Panels in Automatic position;
 - Protection with floater against waterless operation
 - Protection against phase interruption and imbalance
 - There is co-aging execution by changing turns on each operation.
- During panel's protection relay failure, it works via pressure switches on Manuel position against waterless operation.



Kalasanati.com



Figure 7: Front view of double pump pressure switch controlled

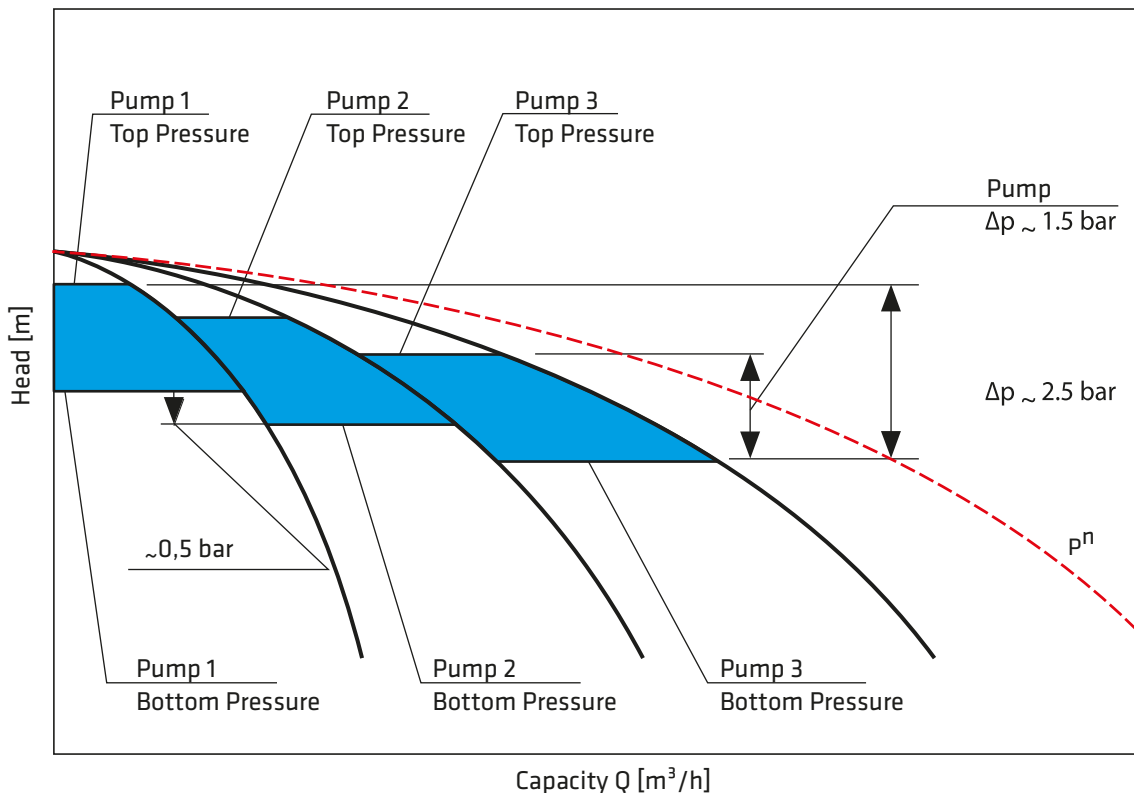

Figure 8. Control Panel With Pressure Sensors



Frequency controlled panel properties

- Works with 380-460 V AC 50 Hz / 60 Hz mains voltage.
- Panel frame is painted with IP 54 protection classed RAL 7032 electrostatic paint
- Panels have ventilation and filter.
- Panel switch can be controlled from front panel.
- Frequency converter device has overheat, motor overheat, motor overcurrent, short circuit, earth leakage, non-overload fault, motor phase loss, over and undervoltage protection and as standard internal EMC and entry shock coil.
- Panel is protected against mains phase loss imbalance and phase reversal.
- During phase fault, user is warned by signal lamps.
- For motors and frequency converter, there are separate thermal motor protection switches and fuses.
- Up to 4 pump applications in the PFC Macro system, system automation is controlled through PFC macro software and advanced LCD panel by an electronic card on the converter.
- When the number of pumps are 5 or more in PLCOPRT system, PLC and touch panel are used. Via software in the PLC, system automation is controlled by touch panel.
- Upon request, optionally, PLC operator system can be provided in all multi pumps.
- Up to 7,5 kW pumps are operated on direct start, 11 kW and above are operated on star-delta start. Optionally, instead of star-delta start soft start can be used.
- For each motor there are separate ON/OFF keys. Moreover, system can be operated as Automatic or Manual by separate switch.
- In AUTO position, in the PFC MACRO system, the pressure information from the 1 pressure sensor at the pumps collector output is input to the converter in 4-20mA as analogue. The control software adjusts the pump speed as to provide outlet pressure to the set pressure value from operator panel. When the required pump capacity is exceeded, a second pump is switched on from the network and the pump running on the converter adapts itself according to the new situation and provides regulation. In each additional pump the situation continues in the same way. When the need for water decreases, the pump goes to standby. It steps in again if needed and continues to work in the same way. When there is a problem with any pump, the pump is switched on automatically. After each standby state, the pump entering the circuit runs in sequence.

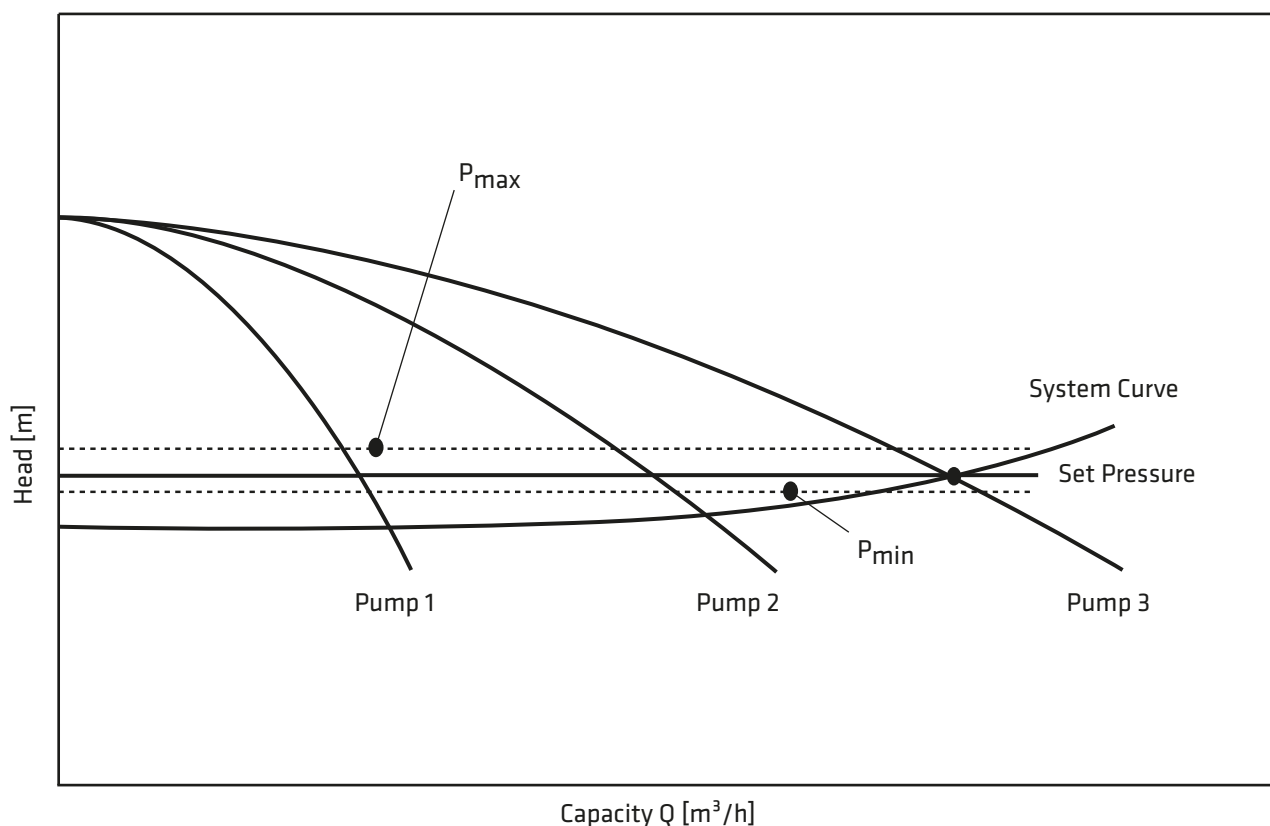

Figure 9. Frequency Controlled Booster

•The operation in PLC OPRT system in AUTO mode is same as above. The pressure sensor is connected to the PLC and the pumps are controlled via the software in the PLC. System information entries are made via the operator touch panel located on the panel.

•In case of a malfunction on the electronic system or on the converter in MANUEL position, the pumps that are switched on are operated directly or star-delta via the contactors on the panel. In this case, the pressure is adjusted by the pressure switches at the outlet of the collector.

- Separate operating and fault lamp for each motor.
- Lamp for converter failure.
- Lamp for phase protection.
- Dry contact output for general failure.
- Panel is delivered as ready to commissioning.
- The input shock coil is available as STANDARD to reduce the harmonic distortion in the mains supplied by the panel.



Figure 10: Front view of triple pump frequency controlled panel



Kalasanati.com

Minimum Pipe and Valve Diameters for Suction Boosters					
	Suction Pipe	Flap		Suction Pipe	Flap
SB M/T 80	1¼"	1½"	CDLF 4	1½"	2"
SB M/T 90	1½"	2"	CDLF 8	2"	2½"
SB M/T 100	2"	2½"	CDLF 12	2"	2½"
GRV VD	2"	2½"	CDLF 16	2"	2½"
GRV VB	2"	2½"	CDLF 20	2½"	3"
SKMV 32	2"	2½"	CDLF 32	2½"	3"
SKMV 40	2½"	3"	CDLF 42	3"	4"
SKMV 50	3"	4"	CDLF 65	4"	5"
SKMV 65	4"	5"	CDLF 85	4"	5"

NOTE: Recommendation for suction pipe diameter is given for steel pipe, if plastic pipe is used diameter of pipe should be increased.

Table 4

Standard

Pump • Fire Fighting Units • Booster Set



kalasanati.com
Training, Selecting, Purchasing

BOOSTERS



Pump • Fire Fighting Units • Booster Set

TH CDLF

STAINLESS BOOSTERS



General Information

High pressure, quiet running, compact and low power consumption.

All surfaces that contact with the liquid are stainless steel, In-line (straight pipe attachable) type pumps.

CDLF pumps are suitable for pumping non-abrasive, clean or slightly contaminated, low-viscosity liquids without solid & fibrous particles.

Bearing is provided by tungsten carbide sliding bearings.

Vertical structure saves space.

Technical Data

Capacity _____ up to 110 m³/h

Head _____ up to 160 m

Design Temperature _____ -10 °C to 120 °C

Casing Pressure _____ 10 - 16 - 25 bar

Design Features

•TH CDLF booster pumps are manufactured as vertical pump.

•The booster pumps are produced as single, double and triple pumps as a standard according to the desired flow rate. Upon request, up to 6 pumps can be set.

•For Single-pump booster pumps have a water level float (electric floater).

•Phase control system (PCS) is available in single pump, three-phase motorized booster pumps.

•Sequencing, phase control and liquid level control are standard features for multiple pumped booster pumps.

•Booster pumps can operate in two different modes; automatically and manually.

•Electrical materials used in the booster pump panels are selected from reliable and quality brands.

Booster Designation

TH -1 x CDLF 4 / 10

Booster Type

Number of Pumps

Pump Type

Model

Number of Stage

- Electric motors of high efficiency class conforming to IEC 60034-30 standard are used.
- Booster pumps can be manufactured with valve, check-valve, stainless steel base plate, depending on request.
- The booster pumps can be manufactured as a variable-speed frequency control for convenience.
- At 11 kW and above, the booster pump base plate is NPU iron construction.

Material Information

Part Name	Material	
	Standard	Optional
Pump		
Base Plate	GG 25	-
Stage Casing	AISI 304	-
Intermediate Stage	AISI 304	-
Impeller	AISI 304	-
Shaft	AISI 304	-
Tube	AISI 304	-
Panel	Pressure Switch Controlled	Frequency Controlled
Collector	AISI 304	AISI 316 L / Galvanized Steel
Frame	Galvanized Steel	AISI 316 L
Accessories		
Valve	Brass	AISI 304
Check Valve	Brass	AISI 316

02.2020 / Rev. 3



Shaft Sealing:

Mechanical seal is provided. The pump can be changed without separating the installation/facility.

Stainless Steel Impeller:

Highly productive design produced by Sheet Forming Technology

Rotary Connection Flanges:

Hole axis adjustment is easier by means of the rotating structure.

Pump Bearings:

It has a long life and silent structure by means of tungsten carbide bearings.

Modular Structure:

Ensures to reduce costs of spare parts and stock.

Connection without key technology makes it easy to remove the impellers during maintenance.

Suction and Discharge Casing:

Stainless steel body in-line design makes it easy for installation.

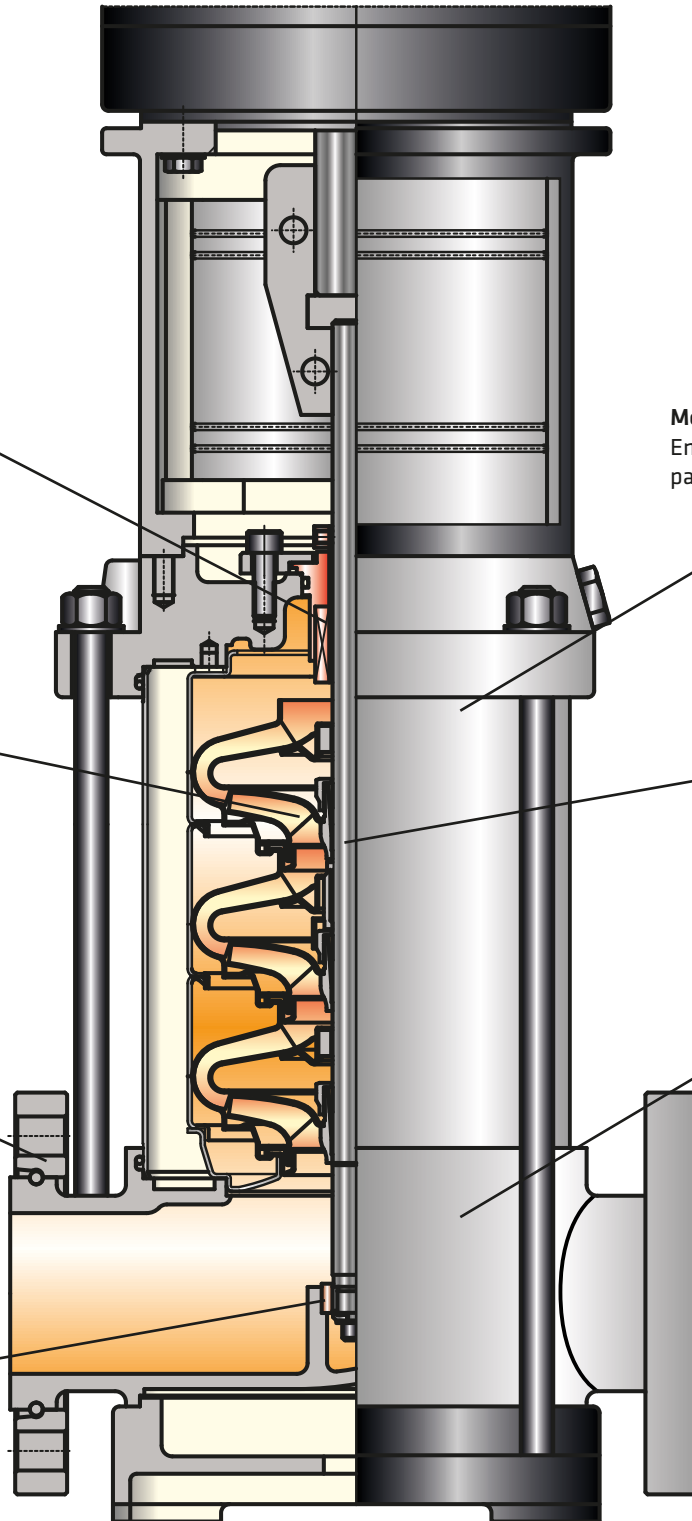



CDLF 4,8,12,16,20

CDLF 32,42,65,85

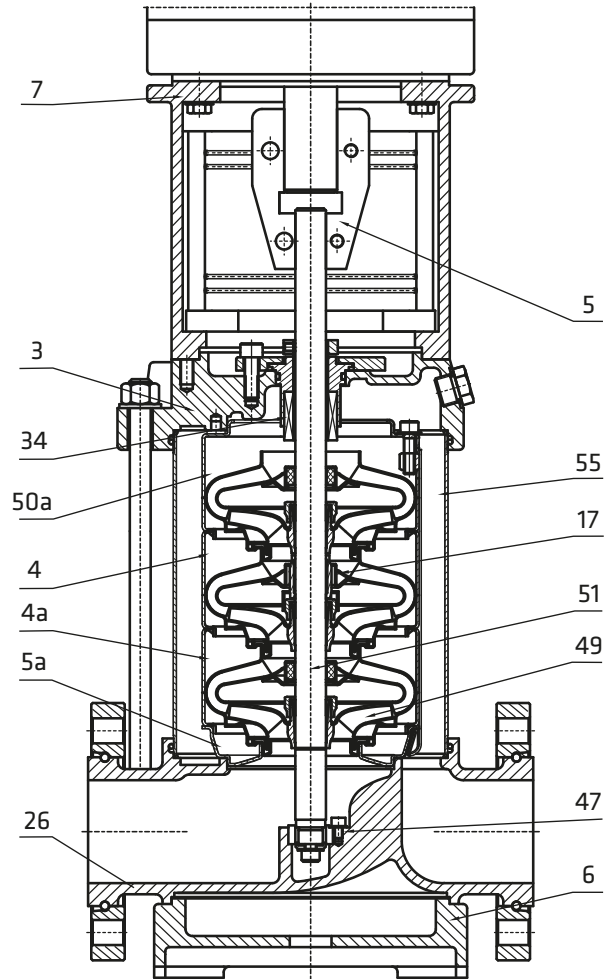
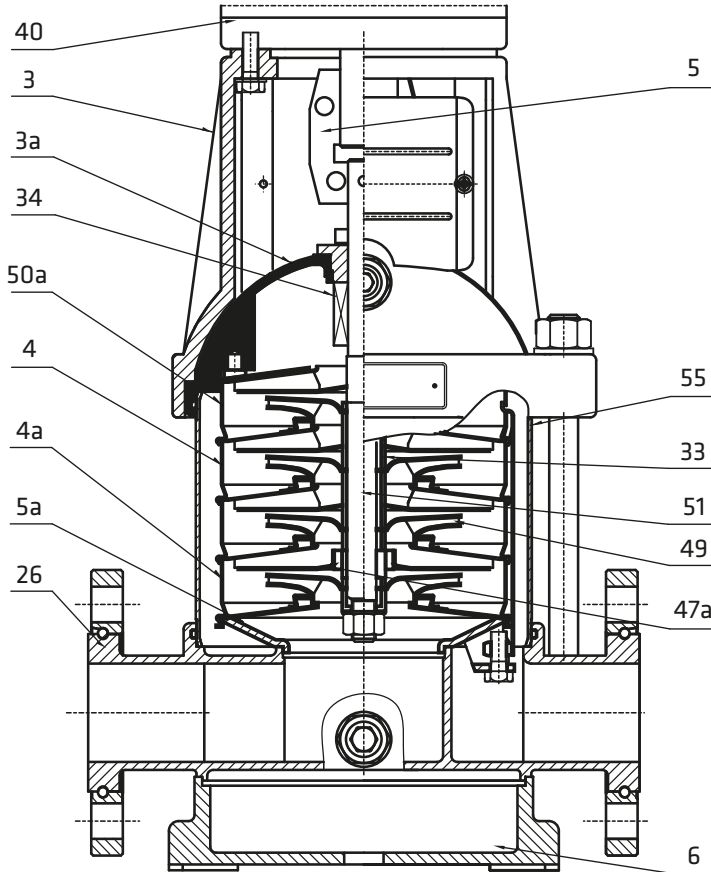

Part List

3	Upper Body	Cast Iron (GG 25)
3a	Liner	Stainless Steel (AISI 304)
4	Diffuser	Stainless Steel (AISI 304)
4a	Lower Diffuser	Stainless Steel (AISI 304)
5	Coupling	Carbon Steel
5a	Inducer	Stainless Steel (AISI 304)
6	Baseplate	Cast Iron (GG 25)
26	Suction and Discharge Casing	Stainless Steel (AISI 304)
33	Sleeve	Stainless Steel (AISI 304)
34	Mechanical Seal	-
40	Electric Motor	-
47a	Bearing	Tungsten carbide
49	Impeller	Stainless Steel (AISI 304)
50a	Upper Diffuser	Stainless Steel (AISI 304)
51	Pump Shaft	Stainless Steel (AISI 304)
55	Cover Plate	Stainless Steel (AISI 304)

3	Upper Body	Stainless steel (AISI 304)
4	Diffuser	Stainless steel (AISI 304)
4a	Lower Diffuser	Stainless steel (AISI 304)
5	Coupling	Carbon Steel
5a	Inducer	Stainless steel (AISI 304)
6	Baseplate	Cast Iron (GG 25)
7	Motor Pedestal	Cast Iron (GG 25)
17	Bearing	Tungsten carbide
26	Suction and Discharge Casing	Stainless steel (AISI 304)
34	Mechanical Seal	-
47	Lower Bearing	Tungsten Carbide
49	Impeller	Stainless steel (AISI 304)
50a	Upper Diffuser	Stainless steel (AISI 304)
51	Pump shaft	Stainless steel (AISI 304)
55	Cover Plate	Stainless steel (AISI 304)

Performance Curve and Dimension Charts



TH CDLF

Kalasanati.com

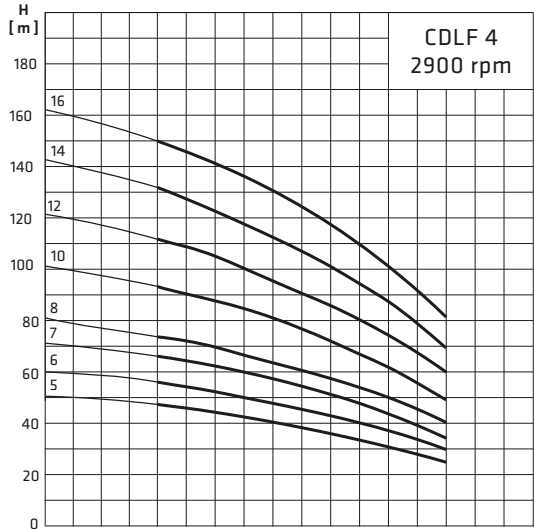

1 Pump 0.0 1.0 2.0 3.0 4.0 5.0 6.0 7.0 Q [m³/h]
 2 Pump 0.0 2.0 4.0 6.0 8.0 10.0 12.0 14.0 Q [m³/h]
 3 Pump 0.0 3.0 6.0 9.0 12.0 15.0 18.0 21.0 Q [m³/h]

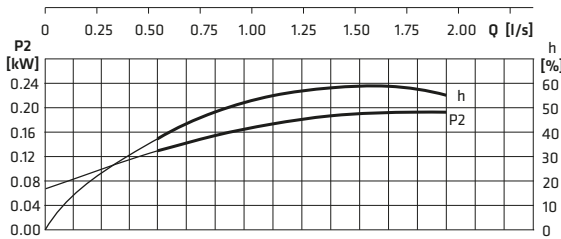

Performance curves are given according to ISO9906: 2012 Gr3B.

Pump Type	kW	De	Db	Ba	Bb	Ba(max)	H	Ka	Kb	E	A	kg
TH-1xCDF 4-5	1,1	1 1/2"	1 1/4"	435	300	650	920	240	410	480	125	39
TH-1xCDF 4-6	920						39					
TH-1xCDF 4-7	920						45					
TH-1xCDF 4-8	1,5	920	45									
TH-1xCDF 4-10	2,2	920	49									
TH-1xCDF 4-12	920	50										
TH-1xCDF 4-14	3	1070	58									
TH-1xCDF 4-16	1070	60										

Pump Type	kW	De	Db	Ba	Bb	H	Ka	Kb	E	A	kg
TH-2xCDF 4-5	1,1	2"	2"	600	785	935	570	500	720	180	115
TH-2xCDF 4-6	935					115					
TH-2xCDF 4-7	935					127					
TH-2xCDF 4-8	1,5	935	127								
TH-2xCDF 4-10	2,2	935	135								
TH-2xCDF 4-12	935	137									
TH-2xCDF 4-14	3	1150	153								
TH-2xCDF 4-16	1150	157									

Pump Type	kW	De	Db	Ba	Bb	H	Ka	Kb	E	A	kg
TH-3xCDF 4-5	1,1	2"	2"	700	800	1045	670	510	720	180	161
TH-3xCDF 4-6	161										
TH-3xCDF 4-7	1,5										179
TH-3xCDF 4-8	1,5	179									
TH-3xCDF 4-10	2,2	191									
TH-3xCDF 4-12	194										
TH-3xCDF 4-14	3	218									
TH-3xCDF 4-16	1150	224									

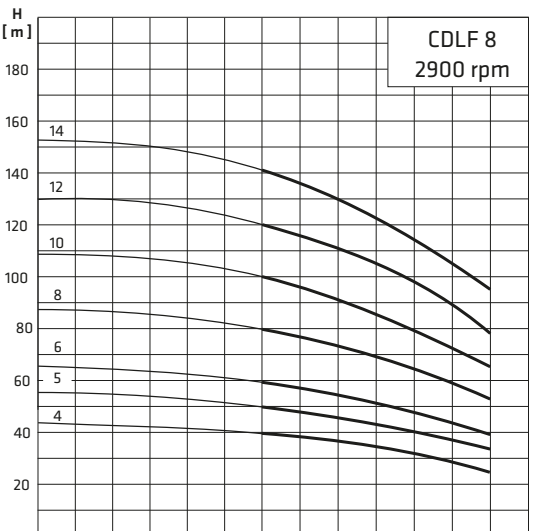

1 Pump 0 2 4 6 8 10 Q [m³/h]
 2 Pump 0 4 8 12 16 20 Q [m³/h]
 3 Pump 0 6 12 18 24 30 Q [m³/h]

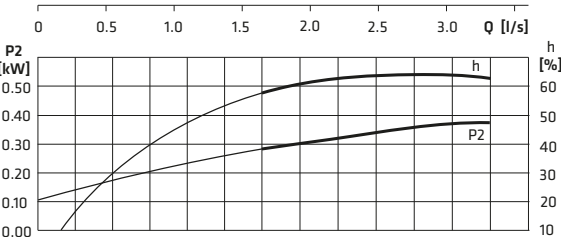

Performance curves are given according to ISO9906: 2012 Gr3B.

Pump Type	kW	De	Db	Ba	Bb	Ba(max)	H	Ka	Kb	E	A	kg
TH-1xCDF 8-4	1,5	2"	1 1/2"	435	300	650	920	240	410	510	130	54
TH-1xCDF 8-5	2,2						920					58
TH-1xCDF 8-6	920						59					
TH-1xCDF 8-8	3	920	67									
TH-1xCDF 8-10	4	920	78									
TH-1xCDF 8-12	920	80										
TH-1xCDF 8-14	5,5	1070	95									

Pump Type	kW	De	Db	Ba	Bb	H	Ka	Kb	E	A	kg
TH-2xCDF 8-4	1,5	2"	2"	650	850	975	620	565	790	185	145
TH-2xCDF 8-5	2,2					975					153
TH-2xCDF 8-6	975					155					
TH-2xCDF 8-8	3	975	171								
TH-2xCDF 8-10	4	1050	193								
TH-2xCDF 8-12	1100	197									
TH-2xCDF 8-14	5,5	1250	227								

Pump Type	kW	De	Db	Ba	Bb	H	Ka	Kb	E	A	kg
TH-3xCDF 8-4	1,5	2 1/2"	2 1/2"	1000	905	1000	970	620	825	185	204
TH-3xCDF 8-5	2,2					1000					216
TH-3xCDF 8-6	1000					219					
TH-3xCDF 8-8	3	1000	243								
TH-3xCDF 8-10	4	1050	276								
TH-3xCDF 8-12	1100	282									
TH-3xCDF 8-14	5,5	1250	327								



Performance Curve and Dimension Charts

TH CDLF

Kalasanati.com

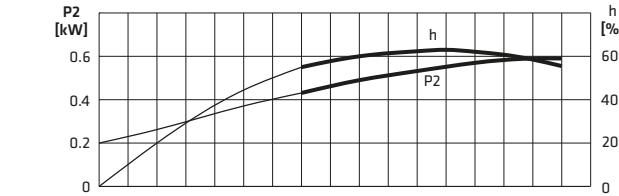
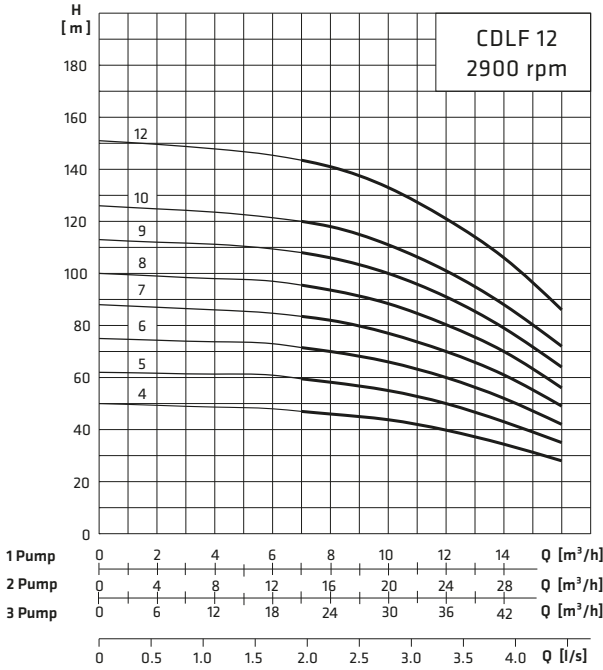

Performance curves are given according to ISO9906: 2012 Gr3B.

Pump Type	kW	De	Db	Ba	Bb	Ba(max)	H	Ka	Kb	E	A	kg
TH-1xCDLF 12-4	3						920					65
TH-1xCDLF 12-5							920					67
TH-1xCDLF 12-6	4						920					75
TH-1xCDLF 12-7							920					87
TH-1xCDLF 12-8	5,5	2"	2"	435	300	650	920	240	410	540	135	88
TH-1xCDLF 12-9							920					90
TH-1xCDLF 12-10							1070					110
TH-1xCDLF 12-12	7,5						1070					114

Pump Type	kW	De	Db	Ba	Bb	H	Ka	Kb	E	A	kg
TH-2xCDLF 12-4	3					985					167
TH-2xCDLF 12-5						985					171
TH-2xCDLF 12-6	4					985					187
TH-2xCDLF 12-7						985					211
TH-2xCDLF 12-8	5,5	2 1/2"	2 1/2"	650	1005	985	620	720	920	195	213
TH-2xCDLF 12-9						1140					217
TH-2xCDLF 12-10						1250					246
TH-2xCDLF 12-12	7,5					1300					254

Pump Type	kW	De	Db	Ba	Bb	H	Ka	Kb	E	A	kg
TH-3xCDLF 12-4	3										237
TH-3xCDLF 12-5											243
TH-3xCDLF 12-6	4										267
TH-3xCDLF 12-7											303
TH-3xCDLF 12-8	5,5	3"	3"	1000	1015	1200	970	720	870	195	306
TH-3xCDLF 12-9											312
TH-3xCDLF 12-10						1300					419
TH-3xCDLF 12-12	7,5					1300					432

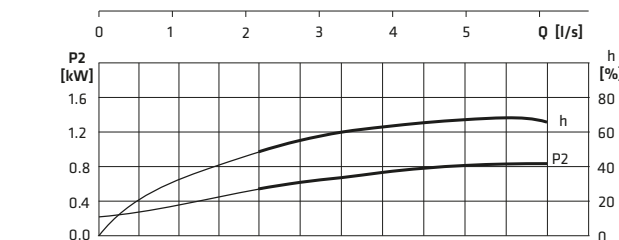
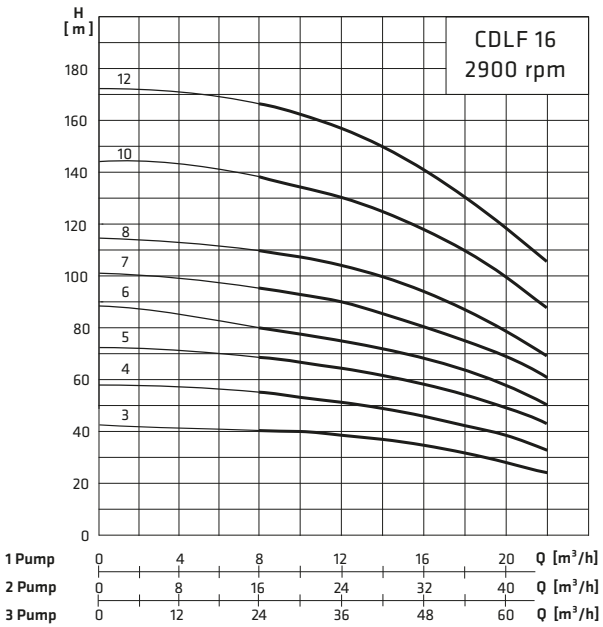

Performance curves are given according to ISO9906: 2012 Gr3B.

Pump Type	kW	De	Db	Ba	Bb	Ba(max)	H	Ka	Kb	E	A	kg
TH-1xCDLF 16-3	3											64
TH-1xCDLF 16-4	4											73
TH-1xCDLF 16-5												90
TH-1xCDLF 16-6	5,5	2"	2"									91
TH-1xCDLF 16-7												98
TH-1xCDLF 16-8	7,5			435	300	1150	1200	240	410	540	130	100
TH-1xCDLF 16-10							1500					182
TH-1xCDLF 16-12	11						1500					185

Pump Type	kW	De	Db	Ba	Bb	H	Ka	Kb	E	A	kg
TH-2xCDLF 16-3	3					1050					165
TH-2xCDLF 16-4	4					1100					183
TH-2xCDLF 16-5						1120					217
TH-2xCDLF 16-6	5,5	2 1/2"	2 1/2"	650	1005	1150	620	720	860	195	219
TH-2xCDLF 16-7						1200					233
TH-2xCDLF 16-8	7,5					1400					237
TH-2xCDLF 16-10						1500					396
TH-2xCDLF 16-12	11					1600					402

Pump Type	kW	De	Db	Ba	Bb	H	Ka	Kb	E	A	kg
TH-3xCDLF 16-3	3					1050					234
TH-3xCDLF 16-4	4					1100					261
TH-3xCDLF 16-5						1120					312
TH-3xCDLF 16-6	5,5	3"	3"	1000	1015	1150	970	720	870	205	315
TH-3xCDLF 16-7						1200					336
TH-3xCDLF 16-8	7,5					1400					342
TH-3xCDLF 16-10						1500					591
TH-3xCDLF 16-12	11					1600					599



Kalasanati.com

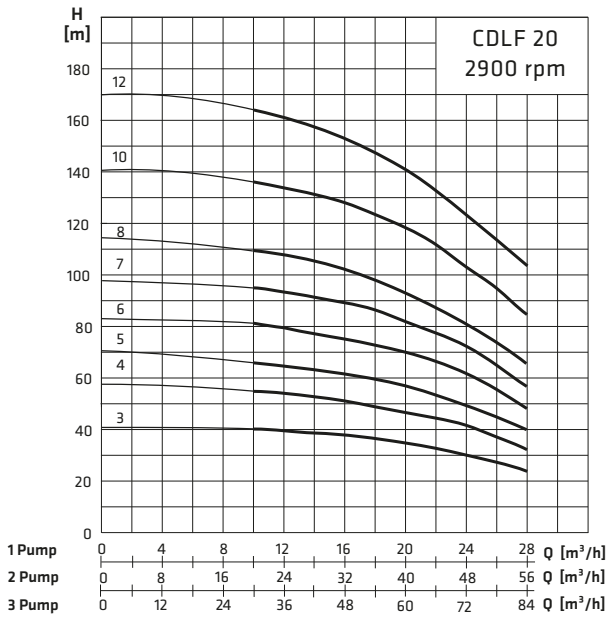

Pump Type	kW	De	Db	Ba	Bb	Ba(max)	H	Ka	Kb	E	A	kg
TH-1xCDLF 20-3	4	2"	2"	430	300	1150	1100	410	230	540	135	72
TH-1xCDLF 20-4	1100						88					
TH-1xCDLF 20-5	5,5						1100					90
TH-1xCDLF 20-6	7,5						1100					96
TH-1xCDLF 20-7	11						1100					98
TH-1xCDLF 20-8	11						1350					179
TH-1xCDLF 20-10	11						1450					183
TH-1xCDLF 20-12	15						1600					196

Pump Type	kW	De	Db	Ba	Bb	H	Ka	Kb	E	A	kg
TH-2xCDLF 20-3	4	2 1/2"	2 1/2"	650	1005	1000	620	720	920	195	181
TH-2xCDLF 20-4	5,5					1050					213
TH-2xCDLF 20-5	5,5					1100					217
TH-2xCDLF 20-6	7,5					1150					229
TH-2xCDLF 20-7	7,5					1200					233
TH-2xCDLF 20-8	11					1400					413
TH-2xCDLF 20-10	11					1500					421
TH-2xCDLF 20-12	15					1600					452

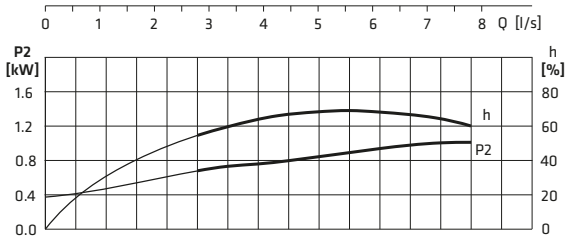

Pump Type	kW	De	Db	Ba	Bb	H	Ka	Kb	E	A	kg
TH-3xCDLF 20-3	4	3"	3"	1000	1015	1050	970	730	935	205	306
TH-3xCDLF 20-4	5,5					1100					354
TH-3xCDLF 20-5	5,5					1120					360
TH-3xCDLF 20-6	7,5					1150					378
TH-3xCDLF 20-7	7,5					1200					384
TH-3xCDLF 20-8	11					1400					611
TH-3xCDLF 20-10	11					1500					623
TH-3xCDLF 20-12	15					1600					667

Performance curves are given according to ISO9906: 2012 Gr3B.



Kalasanati.com

Booster set with one pump

CDLF (4,8,12,16,20) Plate Baseplate design

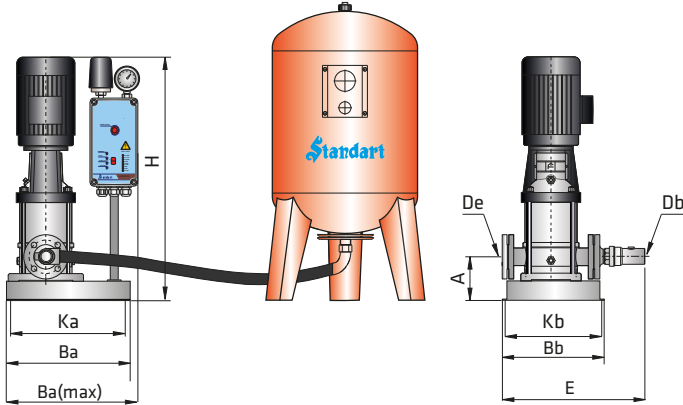

CDLF (32,42,65,85) NPU Baseplate Design

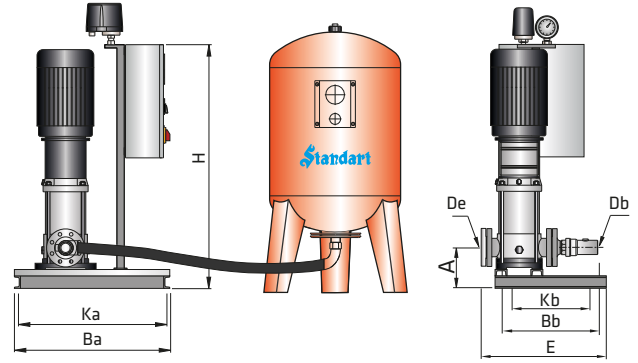

Booster set with two pumps

CDLF (32,42,65,85) NPU Baseplate Design

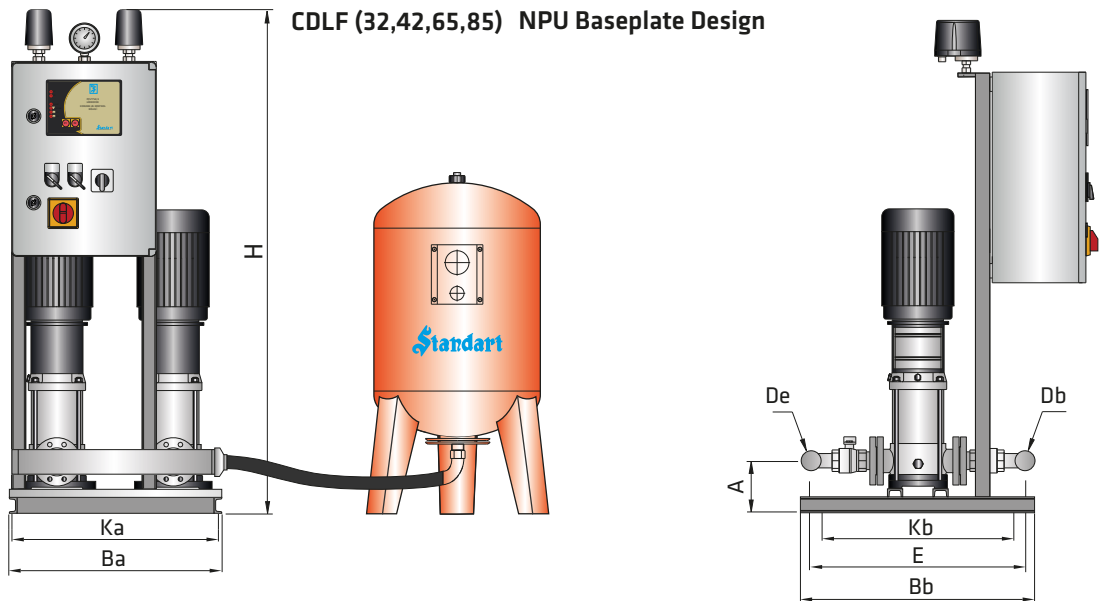

Booster set with three pumps

CDLF (32,42,65,85) NPU Baseplate Design

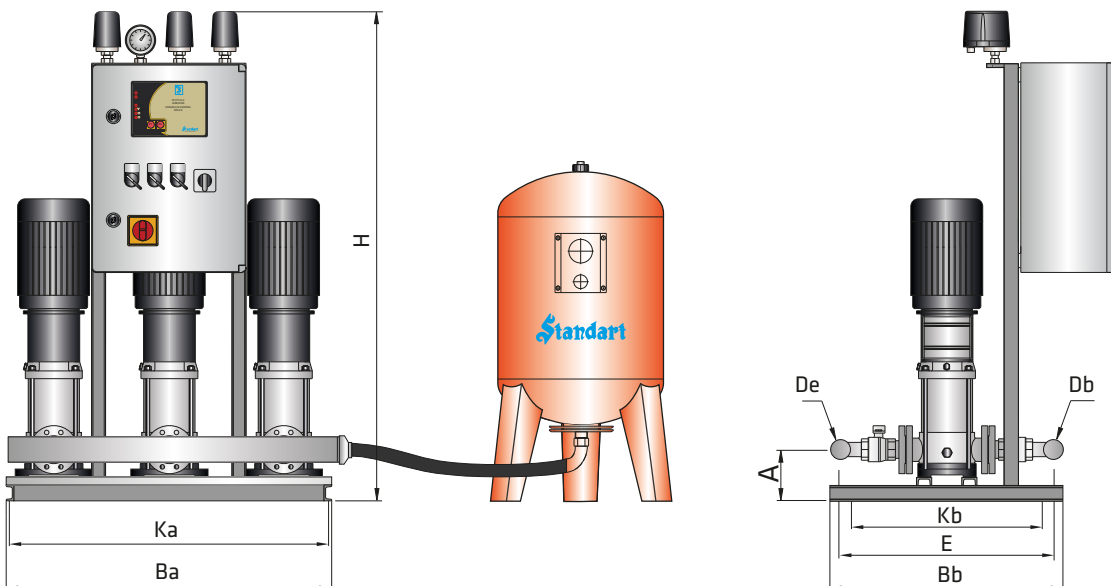



Performance Curve and Dimension Charts

TH CDLF

Kalasanati.com

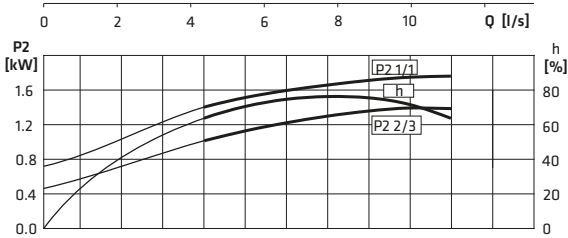
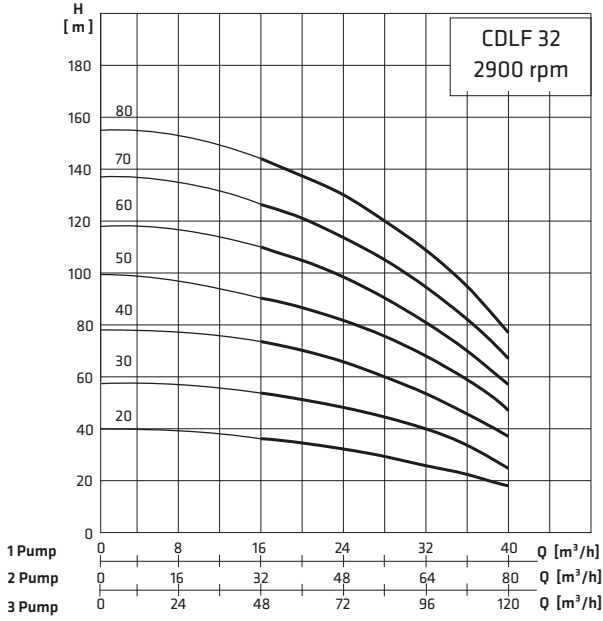

Performance curves are given according to ISO9906: 2012 Gr3B.

Pump Type	kW	De	Db	Ba	Bb	H	Ka	Kb	E	A	Tas.	kg
TH-1xCDLF 32-20	4	2 1/2"	2 1/2"	570	610	1000	530	470	590	235	B	116
TH-1xCDLF 32-30	5,5					1150						131
TH-1xCDLF 32-40	7,5					1200						140
TH-1xCDLF 32-50	11					1550						241
TH-1xCDLF 32-60						1600						245
TH-1xCDLF 32-70	15					1650						264
TH-1xCDLF 32-80						1750						268

Pump Type	kW	De	Db	Ba	Bb	H	Ka	Kb	E	A	Tas.	kg
TH-2xCDLF 32-20	4	4"	4"	850	930	1000	810	790	890	235	B	273
TH-2xCDLF 32-30	5,5					1150						303
TH-2xCDLF 32-40	7,5					1250						321
TH-2xCDLF 32-50	11					1550						482
TH-2xCDLF 32-60						1650						490
TH-2xCDLF 32-70	15					1700						518
TH-2xCDLF 32-80						1800						526

Pump Type	kW	De	Db	Ba	Bb	H	Ka	Kb	E	A	Tas.	kg
TH-3xCDLF 32-20	4	5"	5"	1300	950	1000	1260	810	915	235	B	413
TH-3xCDLF 32-30	5,5					1150						458
TH-3xCDLF 32-40	7,5					1250						485
TH-3xCDLF 32-50	11					1550						721
TH-3xCDLF 32-60						1650						733
TH-3xCDLF 32-70	15					1700						780
TH-3xCDLF 32-80						1800						792

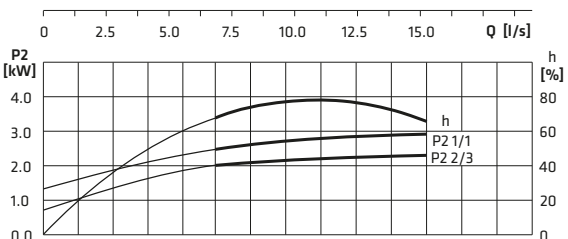
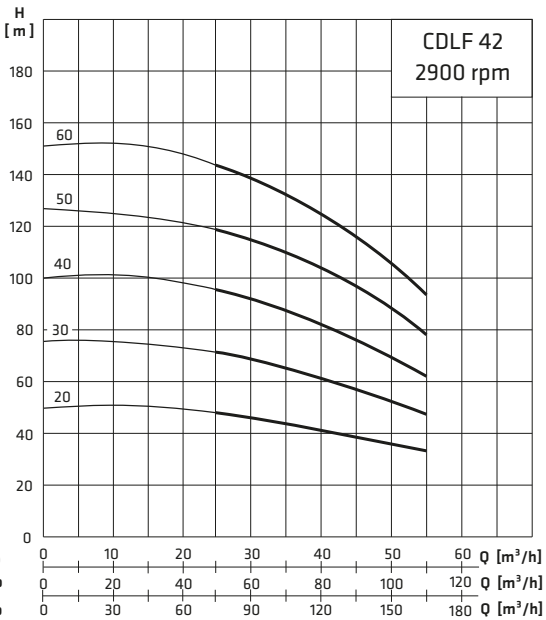

Performance curves are given according to ISO9906: 2012 Gr3B.

Pump Type	kW	De	Db	Ba	Bb	H	Ka	Kb	E	A	Tas.	kg
TH-1xCDLF 42-20	7,5	3"	3"	570	570	1250	530	430	550	285	B	149
TH-1xCDLF 42-30	11					1450						222
TH-1xCDLF 42-40	15					1550						236
TH-1xCDLF 42-50	18,5					1700						260
TH-1xCDLF 42-60	22					1800						300

Pump Type	kW	De	Db	Ba	Bb	H	Ka	Kb	E	A	Tas.	kg
TH-2xCDLF 42-20	7,5	4"	4"	850	1075	1250	810	935	1035	285	B	332
TH-2xCDLF 42-30	11					1500						493
TH-2xCDLF 42-40	15					1600						521
TH-2xCDLF 42-50	18,5					1750						569
TH-2xCDLF 42-60	22					1850						649

Pump Type	kW	De	Db	Ba	Bb	H	Ka	Kb	E	A	Tas.	kg
TH-3xCDLF 42-20	7,5	5"	5"	1300	1100	1250	1260	960	1060	285	B	500
TH-3xCDLF 42-30	11					1500						739
TH-3xCDLF 42-40	15					1600						786
TH-3xCDLF 42-50	18,5					1750						858
TH-3xCDLF 42-60	22					1850						978

Belirtilen ölçü ve ağırlıklar takribidir. Her türlü değişiklik hakkımız saklıdır.

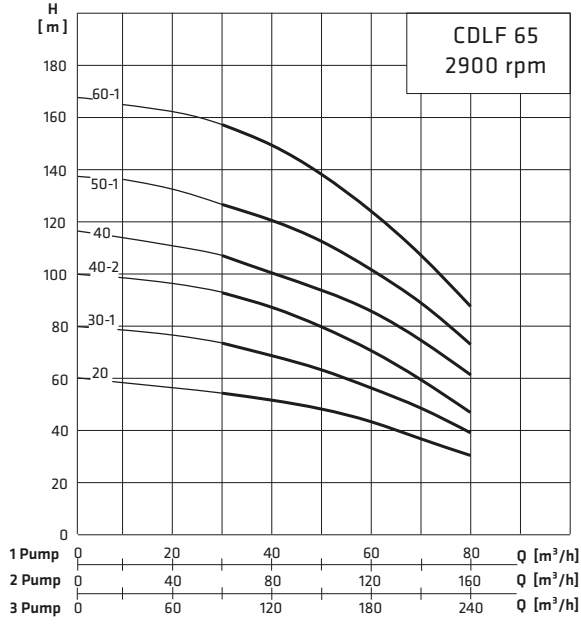

Pump Type	kW	De	Db	Ba	Bb	H	Ka	Kb	E	A	Tas.	kg
TH-1xCDLF 65-20	11	4"	4"	570	600	1450	530	460	585	320	B	221
TH-1xCDLF 65-30-1	15					1550						236
TH-1xCDLF 65-40-2	18,5					1650						264
TH-1xCDLF 65-40	22					1700						297
TH-1xCDLF 65-50-1	30					1850						358
TH-1xCDLF 65-60-1	37					1950						388

Pump Type	kW	De	Db	Ba	Bb	H	Ka	Kb	E	A	Tas.	kg
TH-2xCDLF 65-20	11	5"	5"	850	1150	1500	810	1010	1085	320	B	486
TH-2xCDLF 65-30-1	15					1550						531
TH-2xCDLF 65-40-2	18,5					1700						592
TH-2xCDLF 65-40	22					1750						663
TH-2xCDLF 65-50-1	30					1900						785
TH-2xCDLF 65-60-1	37					2000						850

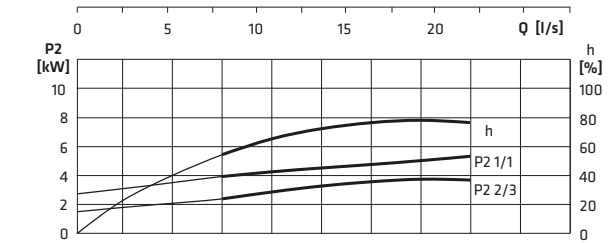

Performance curves are given according to ISO9906: 2012 Gr3B.

Pump Type	kW	De	Db	Ba	Bb	H	Ka	Kb	E	A	Tas.	kg
TH-3xCDLF 65-20	11	6"	6"	1300	1150	1500	1260	1010	1110	320	B	731
TH-3xCDLF 65-30-1	15					1550						796
TH-3xCDLF 65-40-2	18,5					1700						885
TH-3xCDLF 65-40	22					1750						984
TH-3xCDLF 65-50-1	30					1900						1167
TH-3xCDLF 65-60-1	37					2000						1262

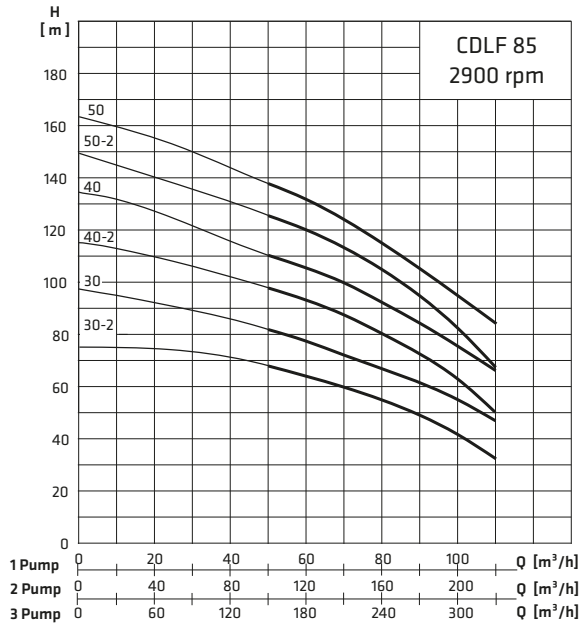

Pump Type	kW	De	Db	Ba	Bb	H	Ka	Kb	E	A	Tas.	kg
TH-1xCDLF 85-30-2	18,5	4"	4"	570	600	1650	530	460	600	340	B	254
TH-1xCDLF 85-30	22					1700						291
TH-1xCDLF 85-40-2	30					1850						351
TH-1xCDLF 85-40	30					1850						351
TH-1xCDLF 85-50-2	37					1950						375
TH-1xCDLF 85-50	37					1950						375

Pump Type	kW	De	Db	Ba	Bb	H	Ka	Kb	E	A	Tas.	kg
TH-2xCDLF 85-30-2	18,5	6"	6"	850	1150	1700	810	1010	1125	340	B	562
TH-2xCDLF 85-30	22					1700						651
TH-2xCDLF 85-40-2	30					1900						776
TH-2xCDLF 85-40	30					1900						781
TH-2xCDLF 85-50-2	37					2000						829
TH-2xCDLF 85-50	37					2000						834

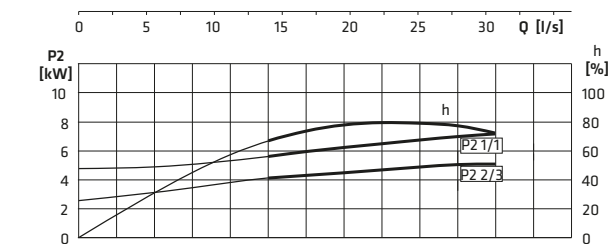

Performance curves are given according to ISO9906: 2012 Gr3B.

Pump Type	kW	De	Db	Ba	Bb	H	Ka	Kb	E	A	Tas.	kg
TH-3xCDLF 85-30-2	18,5	8"	8"	1300	1250	1700	1260	1110	1180	340	B	860
TH-3xCDLF 85-30	22					1700						991
TH-3xCDLF 85-40-2	30					1900						1176
TH-3xCDLF 85-40	30					1900						1176
TH-3xCDLF 85-50-2	37					2000						1248
TH-3xCDLF 85-50	37					2000						1253

Belirtilen ölçü ve ağırlıklar takribidir. Her türlü değişiklik hakkımız saklıdır.

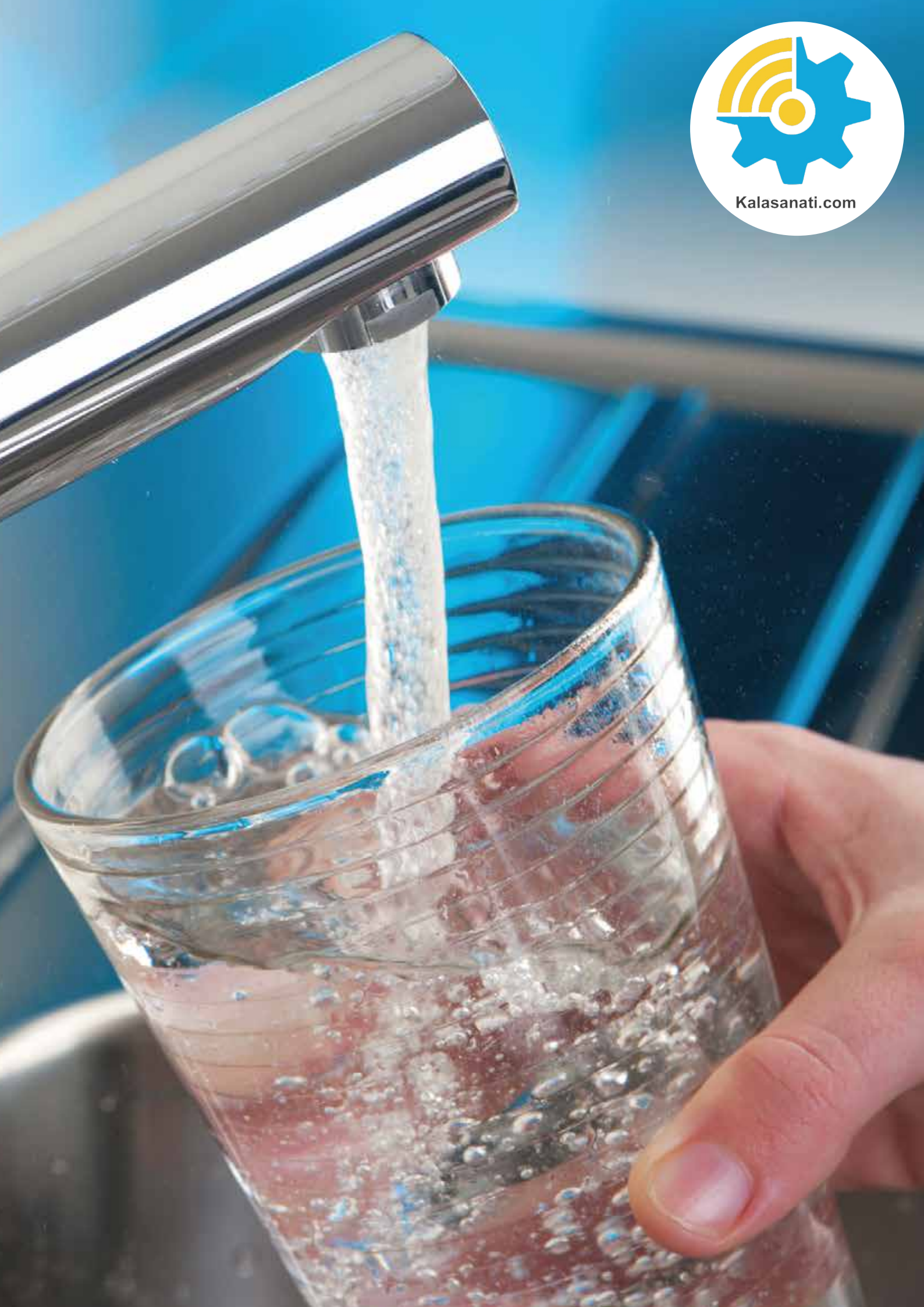

Kalasanati.com



Pump • Fire Fighting Units • Booster Set

TH SB BOOSTERS



General Information

It is high pressure, quiet running, compact and low power consumption.

SB pumps are suitable for pumping non-abrasive, clean or slightly contaminated, low viscosity liquids without solid & fibrous particles.

Vertical structure saves space.

Technical Data

Flow _____ up to 15 m³/h

Head _____ up to 120 m

Design Temperature _____ 0 °C to 50 °C

Casing Pressure _____ 10 - 16 bar

Design Features

- TH SB booster is manufactured with horizontal or vertical pump.
- The boosters are produced as single, double and triple pumps as a standard according to the desired flow. Upon request, up to 6 pumps can be set.
- Single-pump boosters have a water level float (electric floater).
- Phase control system (PCS) is available in single pump, three-phase motorized boosters.
- Sequencing, phase control and liquid level control are standard features for multiple pumped booster pumps.
- Booster pumps can operate in two different modes; automatically and manually.
- Electrical materials used in the booster pump panels are selected from reliable and quality brands.
- The booster pumps can be manufactured as a variable-speed frequency control for convenience.

Material Equivalents

Part Name	Material	
	Standard	Optional
Pump		
Base Plate	GG 25	-
Stage Casing	NORYL	-
Intermediate Stage	NORYL	-
Impeller	NORYL	-
Shaft	AISI 420	-
Cover Plate	AISI 304	-
Panel	Pressure Switch Controlled	Frequency Controlled
Collector	Galvanized Steel	AISI 304
Frame	Galvanized Steel	-
Accessories		
Valve	Brass	-
Check Valve	Brass	-

Booster Designation

Booster Type _____

Number of Pumps _____

Pump Type _____

T : Three-phase M : Mono-Phase _____

Vertical Installation _____

Motor Building Size _____

Number of Stages _____

TH 1x SB T-V 80 /10



Horizontal boosters with tanks

Kalasanti.com

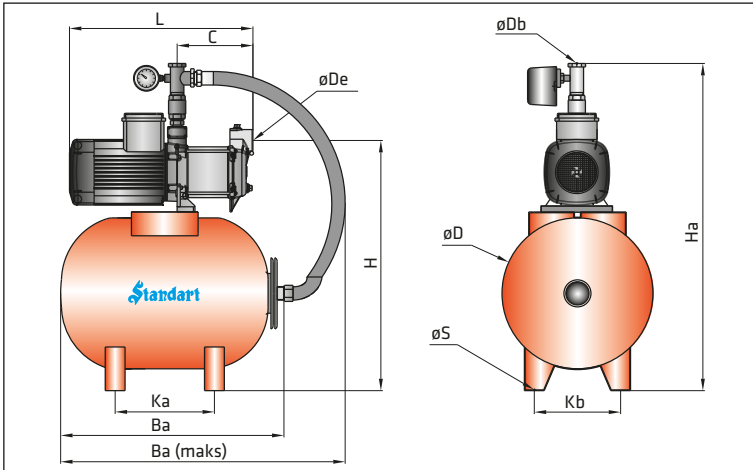

24 Liter Tank	De	Db	Ba	Ba(maks)	H	Ha	Ka	Kb	L	C	øD	øS	KG
SBM 80/5-24	1 1/4"	1"	480	587	465	669	190	158	455	200	265	10	25,8
SBM 80/6-24									475	230			26,3
SBM 80/7-24									500	250			26,9
SBM 80/8-24									520	270			28,1
SBM 80/9-24									540	295			28,8
24 Liter Tank	De	Db	Ba	Ba(maks)	H	Ha	Ka	Kb	L	C	øD	øS	KG
SBT 80/5-24	1 1/4"	1"	480	587	465	669	190	158	453	206	265	10	24,3
SBT 80/6-24									475	228			24,8
SBT 80/7-24									497	250			26,1
SBT 80/8-24									519	272			26,3
SBT 80/9-24									541	294			26,8
SBT 80/10-24									563	316			28,3
SBT 80/11-24	585	338	29										
50 Liter Tank	De	Db	Ba	Ba(maks)	H	Ha	Ka	Kb	L	C	øD	øS	KG
SBM 80/5-50	1 1/4"	1"	600	696	565	779	220	232	453	206	280	10	31,7
SBM 80/6-50									475	228			32,2
SBM 80/7-50									497	250			32,8
SBM 80/8-50									519	272			34
SBM 80/9-50									541	294			34,7
50 Liter Tank	De	Db	Ba	Ba(maks)	H	Ha	Ka	Kb	L	C	øD	øS	KG
SBT 80/5-50	1 1/4"	1"	600	696	565	779	220	232	453	206	380	10	30,2
SBT 80/6-50									475	228			30,7
SBT 80/7-50									497	250			32
SBT 80/8-50									519	272			32,2
SBT 80/9-50									541	294			32,7
SBT 80/10-50									563	316			34,7
SBT 80/11-50	585	338	35										
50 Liter Tank	De	Db	Ba	Ba(maks)	H	Ha	Ka	Kb	L	C	øD	øS	KG
SBM 90/4-50	1 1/4"	1 1/4"	600	696	603	796	220	232	489	218	380	10	39,3
SBM 90/5-50									517	246			41,3
SBM 90/6-50									545	274			41,8
50 Liter Tank	De	Db	Ba	Ba(maks)	H	Ha	Ka	Kb	L	C	øD	øS	KG
SBT 90/4-50	1 1/4"	1 1/4"	600	696	603	796	220	232	489	218	380	10	37,3
SBT 90/5-50									517	246			39,3
SBT 90/6-50									545	274			40,3
SBT 90/7-50									573	302			42,3
80 Liter Tank	De	Db	Ba	Ba(maks)	H	Ha	Ka	Kb	L	C	øD	øS	KG
SBM 90/4-80	1 1/4"	1 1/4"	635	828	708	901	330	276	489	218	460	10	44,1
SBM 90/5-80									517	246			46,1
SBM 90/6-80									545	274			46,6
80 Liter Tank	De	Db	Ba	Ba(maks)	H	Ha	Ka	Kb	L	C	øD	øS	KG
SBT 90/4-80	1 1/4"	1 1/4"	635	828	708	901	330	276	489	218	460	10	42,1
SBT 90/5-80									517	246			44,1
SBT 90/6-80									545	274			45,1
SBT 90/7-80									573	302			47,1
80 Liter Tank	De	Db	Ba	Ba(maks)	H	Ha	Ka	Kb	L	C	øD	øS	KG
SBT 100/3-80	1 1/2"	1 1/2"	635	880	746	1007	330	276	530	219	460	10	51,3
SBT 100/4-80									563	252			52,8
SBT 100/5-80									596	285			58
100 Liter Tank	De	Db	Ba	Ba(maks)	H	Ha	Ka	Kb	L	C	øD	øS	KG
SBT 100/3-100	1 1/2"	1 1/2"	820	940	746	1007	330	276	530	219	460	10	52,6
SBT 100/4-100									563	252			54,1
SBT 100/5-100									596	285			59,3

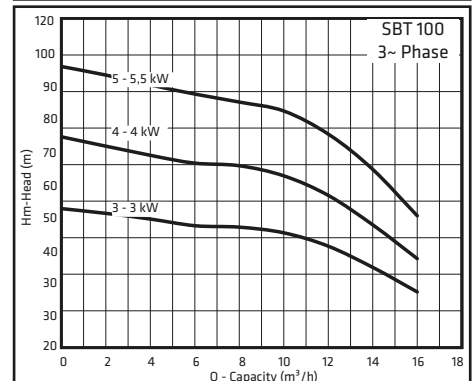
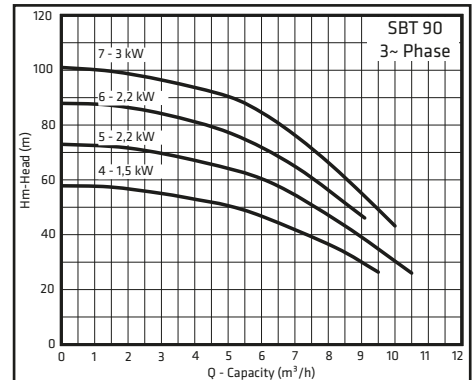
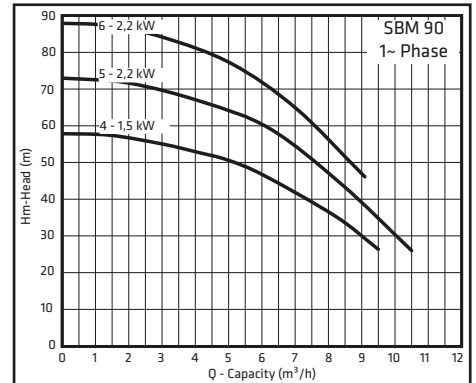
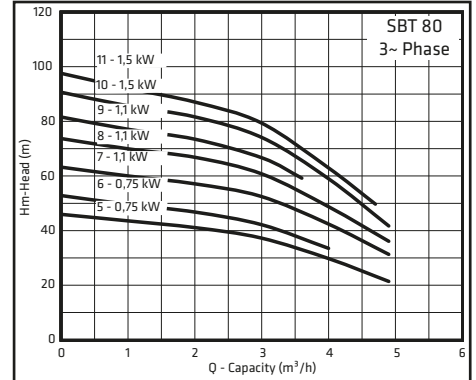
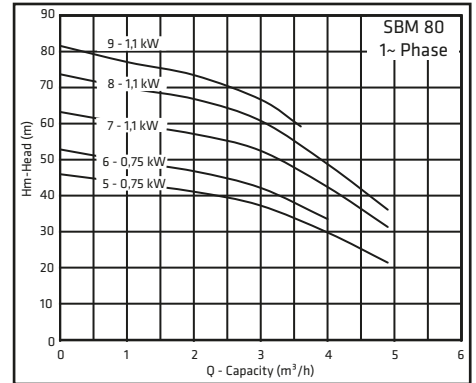



Booster set with one pump

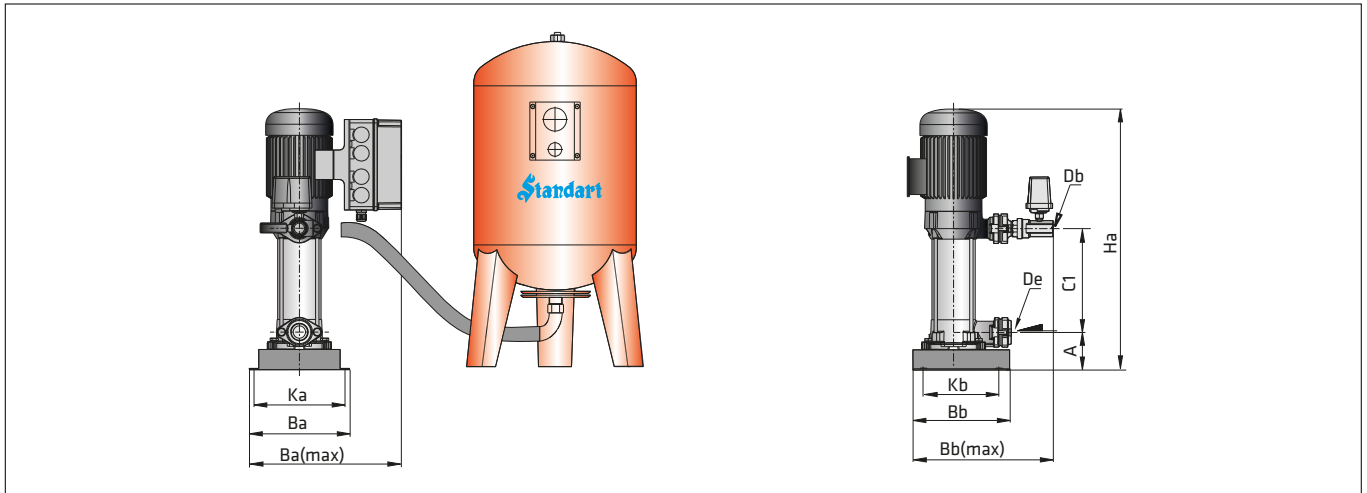

Booster set with two pumps

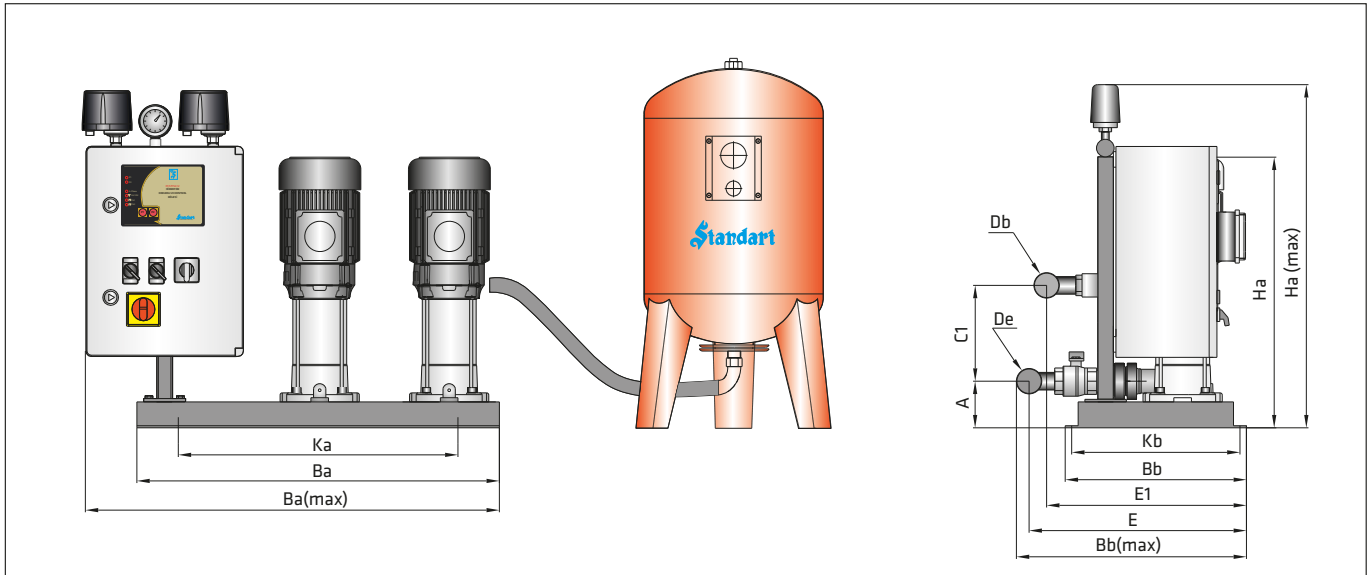

Booster set with three pumps

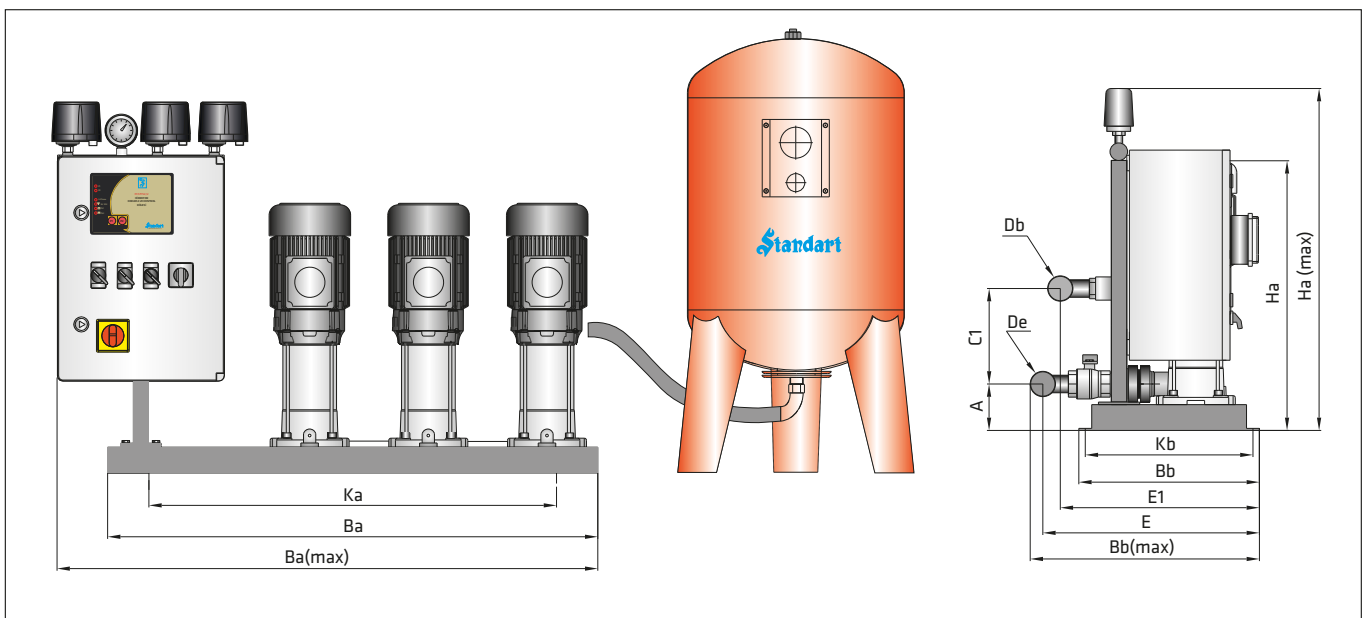

Performance Curves and Dimensions



Kalasanati.com

TH SB

	De	Db	Ba	Bb	Ba(maks)	Bb(maks)	Ha	Ka	Kb	E	E1	A	C1	KG
1xSBM-V 80/5	1 1/4"	1 1/4"	240	230	360	335	517	220	180	-	-	85	184	26,5
1xSBM-V 80/6							539						206	27
1xSBM-V 80/7							561						228	27,6
1xSBM-V 80/8							583						250	28,8
1xSBM-V 80/9							605						272	29,5

	De	Db	Ba	Bb	Ba(maks)	Bb(maks)	Ha	Ka	Kb	E	E1	A	C1	KG
1xSBT-V 80/5	1 1/4"	1 1/4"	240	230	350	350	560	220	180	-	-	90	184	25
1xSBT-V 80/6							580						206	25,5
1xSBT-V 80/7							600						228	26,8
1xSBT-V 80/8							620						250	27
1xSBT-V 80/9							670						272	27,5
1xSBT-V 80/10							690						294	29
1xSBT-V 80/11							730						316	30
1xSBT-V 80/12	770	338	30,5											

	De	Db	Ba	Bb	Ba(maks)	Bb(maks)	Ha	Ha(maks)	Ka	Kb	E	E1	A	C1	KG
2xSBM-V 80/5	1 1/4"	1 1/4"	700	350	825	445	522	753	630	320	420	390	90	185	66
2xSBM-V 80/6							544							205	67
2xSBM-V 80/7							566							228	69
2xSBM-V 80/8							588							250	71
2xSBM-V 80/9							610							272	72,5

	De	Db	Ba	Bb	Ba(maks)	Bb(maks)	Ha	Ha(maks)	Ka	Kb	E	E1	A	C1	KG
2xSBT-V 80/5	1 1/4"	1 1/4"	695	345	800	400	560	720	645	325	375	370	90	185	63
2xSBT-V 80/6							580							205	64
2xSBT-V 80/7							600							228	66,5
2xSBT-V 80/8							620							250	67
2xSBT-V 80/9							670							272	68
2xSBT-V 80/10							690							294	71
2xSBT-V 80/11							730							316	72,5
2xSBT-V 80/12	770	338	73,5												

	De	Db	Ba	Bb	Ba(maks)	Bb(maks)	Ha	Ha(maks)	Ka	Kb	E	E1	A	C1	KG
3xSBM-V 80/5	1 1/2"	1 1/2"	950	350	1085	460	522	810	880	320	430	400	90	184	97,5
3xSBM-V 80/6							543							206	99
3xSBM-V 80/7							566							228	101
3xSBM-V 80/8							588							250	104
3xSBM-V 80/9							610							272	106

	De	Db	Ba	Bb	Ba(maks)	Bb(maks)	Ha	Ha(maks)	Ka	Kb	E	E1	A	C1	KG
3xSBT-V 80/5	1 1/2"	1 1/2"	950	345	1065	420	560	820	880	325	385	380	125	185	93
3xSBT-V 80/6							580							205	94
3xSBT-V 80/7							600							228	98
3xSBT-V 80/8							620							250	99
3xSBT-V 80/9							670							272	100
3xSBT-V 80/10							690							294	105
3xSBT-V 80/11							730							316	107
3xSBT-V 80/12	770	338	109												

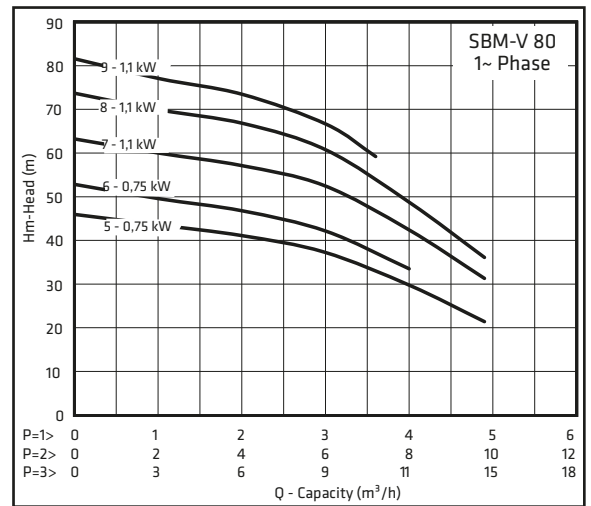
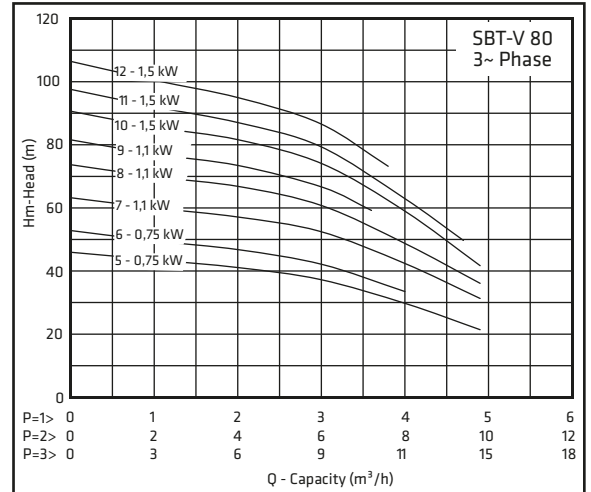

Performance Curves and Dimensions



Kalasanati.com

TH SB

	De	Db	Ba	Bb	Ba(maks)	Bb(maks)	Ha	Ha(maks)	Ka	Kb	E	E1	A	C1	KG
1xSBM-V 90/4	1 1/4"	1 1/4"	245	230	360	354	544	544	225	180	-	-	85	216	34,5
1xSBM-V 90/5	1 1/4"	1 1/4"					572	572						244	37
1xSBM-V 90/6	1 1/4"	1 1/4"					600	600							

	De	Db	Ba	Bb	Ba(maks)	Bb(maks)	Ha	Ha(maks)	Ka	Kb	E	E1	A	C1	KG
1xSBT-V 90/4	1 1/4"	1 1/4"	250	230	360	350	570						90	188	32,5
1xSBT-V 90/5	1 1/4"	1 1/4"					600							216	34,5
1xSBT-V 90/6	1 1/4"	1 1/4"					630	230	180	-	-			244	35,5
1xSBT-V 90/7	1 1/4"	1 1/4"					670							272	37,5
1xSBT-V 90/8	1 1/4"	1 1/4"					710							300	38
1xSBT-V 90/9	1 1/4"	1 1/4"					740							328	39

	De	Db	Ba	Bb	Ba(maks)	Bb(maks)	Ha	Ha(maks)	Ka	Kb	E	E1	A	C1	KG
2xSBM-V 90/4	1 1/2"	1 1/2"	700	350	822	460	550							188	80
2xSBM-V 90/5	1 1/2"	1 1/2"					578	753	630	320	400	432	90	216	84
2xSBM-V 90/6	1 1/2"	1 1/2"					606							244	85

	De	Db	Ba	Bb	Ba(maks)	Bb(maks)	Ha	Ha(maks)	Ka	Kb	E	E1	A	C1	KG
2xSBT-V 90/4	1 1/2"	1 1/2"	700	350	800	430	570							188	76
2xSBT-V 90/5	1 1/2"	1 1/2"					600							216	80
2xSBT-V 90/6	1 1/2"	1 1/2"					630	730	645	325	405	400	90	244	82
2xSBT-V 90/7	1 1/2"	1 1/2"					670							272	86
2xSBT-V 90/8	1 1/2"	1 1/2"					710							300	87
2xSBT-V 90/9	1 1/2"	1 1/2"					740							328	88

	De	Db	Ba	Bb	Ba(maks)	Bb(maks)	Ha	Ha(maks)	Ka	Kb	E	E1	A	C1	KG
3xSBM-V 90/4	2"	2"	950	350	1085	485	550							188	105
3xSBM-V 90/5	2"	2"					578	810	880	320	430	386	90	216	111
3xSBM-V 90/6	2"	2"					606							244	113

	De	Db	Ba	Bb	Ba(maks)	Bb(maks)	Ha	Ha(maks)	Ka	Kb	E	E1	A	C1	KG
3xSBT-V 90/4	2"	2"	950	345	1065	420	570							188	100
3xSBT-V 90/5	2"	2"					600							216	106
3xSBT-V 90/6	2"	2"					630	820	880	325	410	405	125	244	109
3xSBT-V 90/7	2"	2"					670							272	104
3xSBT-V 90/8	2"	2"					710							300	106
3xSBT-V 90/9	2"	2"					740							328	118

	De	Db	Ba	Bb	Ba(maks)	Bb(maks)	Ha	Ha(maks)	Ka	Kb	E	E1	A	C1	KG
1xSBT-V 100/3	1 1/2"	1 1/2"	230	280	430	390	590							186	44
1xSBT-V 100/4	1 1/2"	1 1/2"					620							219	45
1xSBT-V 100/5	1 1/2"	1 1/2"					650	260	185	-	-	100		252	50
1xSBT-V 100/6	1 1/2"	1 1/2"					690							285	51
1xSBT-V 100/7	1 1/2"	1 1/2"					720							318	52

	De	Db	Ba	Bb	Ba(maks)	Bb(maks)	Ha	Ha(maks)	Ka	Kb	E	E1	A	C1	KG
2xSBT-V 100/3	2"	2"	695	345	800	500	590							186	96
2xSBT-V 100/4	2"	2"					620							219	99
2xSBT-V 100/5	2"	2"					650	720	645	325	475	470	100	252	110
2xSBT-V 100/6	2"	2"					690							285	111
2xSBT-V 100/7	2"	2"					720							318	112

	De	Db	Ba	Bb	Ba(maks)	Bb(maks)	Ha	Ha(maks)	Ka	Kb	E	E1	A	C1	KG
3xSBT-V 100/3	2 1/2"	2 1/2"	950	345	1065	515	590							186	143
3xSBT-V 100/4	2 1/2"	2 1/2"					620							219	148
3xSBT-V 100/5	2 1/2"	2 1/2"					650	820	880	325	480	475	135	252	163
3xSBT-V 100/6	2 1/2"	2 1/2"					690							285	165
3xSBT-V 100/7	2 1/2"	2 1/2"					720							318	166

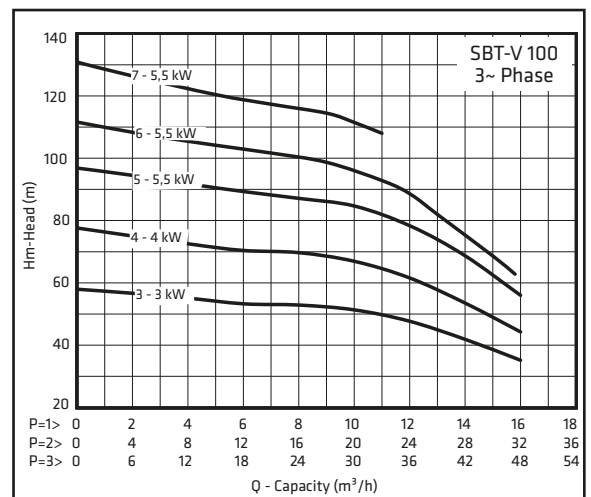
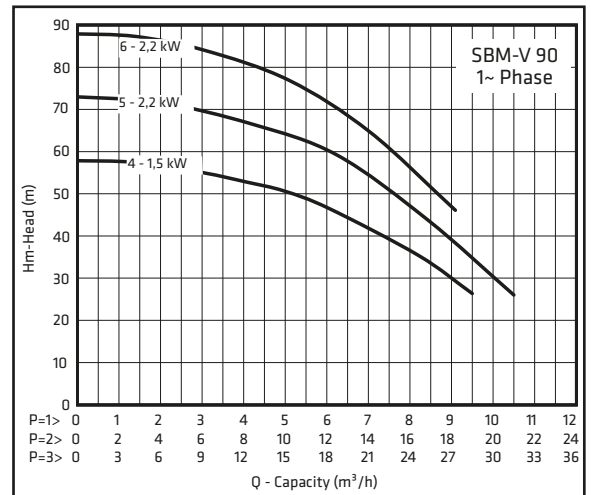
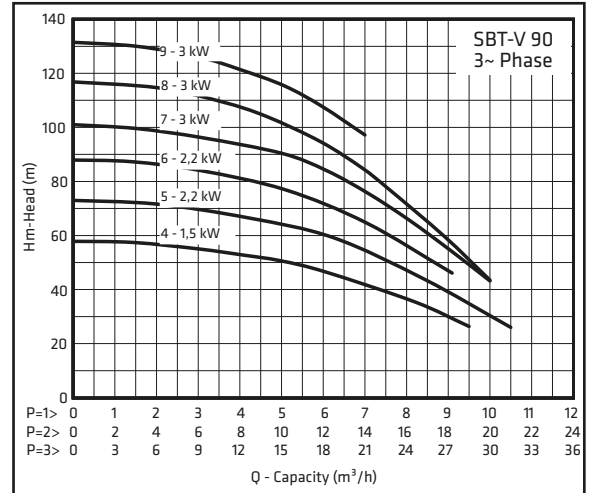



TH SKMV BOOSTERS



General Information

High pressure, quiet running, compact and low power consumption.

SKMV pumps are suitable for pumping non-abrasive, clean or slightly contaminated, low viscosity without solid & fibrous particles liquids.

Vertical structure saves space.

Technical Data

Capacity	_____	up to 500 m ³ /h
Head	_____	up to 180 m
Design Temperature	_____	up to 70 °C
Casing Pressure	_____	10 - 16 - 25 bar

Design Features

- TH SKMV boosters are manufactured with vertical pump.
- The boosters are produced as single, double and triple pumps as a standard according to the desired flow. Upon request, up to 6 pumps can be set.
- Single-pump boosters have a water level float (electric floater).
- Phase control system (PCS) is available in single pump, three-phase motorized boosters.
- Sequencing, phase control and liquid level control are standard features for multiple pumped booster pumps.
- Booster pumps can operate in two different modes; automatically and manually.
- Electrical materials used in the booster pump panels are selected from reliable and quality brands.

Booster Designation

TH 2 x SKMV 50/3

Booster Type	_____
Number of Pumps	_____
Pump Type	_____
Pump Outlet Flange (DN-mm)	_____
Number of Stage	_____

- Electric motors of high efficiency class conforming to IEC 60034-30 standard are used.
- The booster pumps can be manufactured as a variable-speed frequency control for convenience. (upon request)

Material Information

Part Name	Material	
	Standard	Optional
Pump		
Base Plate	GG 25	Bronze / AISI 304
Stage Casing	GG 25	Bronze / AISI 304
Intermediate Stage	GG 25	Bronze / AISI 304
Impeller	Brass	Bronze / AISI 304
Shaft	AISI 420	AISI 304
Panel	Pressure Switch Controlled	Frequency Controlled
Collector	Galvanized Steel	AISI 304
Frame	Fabricated Steel	-
Accessories		
Valve	Brass	AISI 304
Check Valve	Brass	AISI 316



Performance Curves

TH SKMV

Kalasanati.com

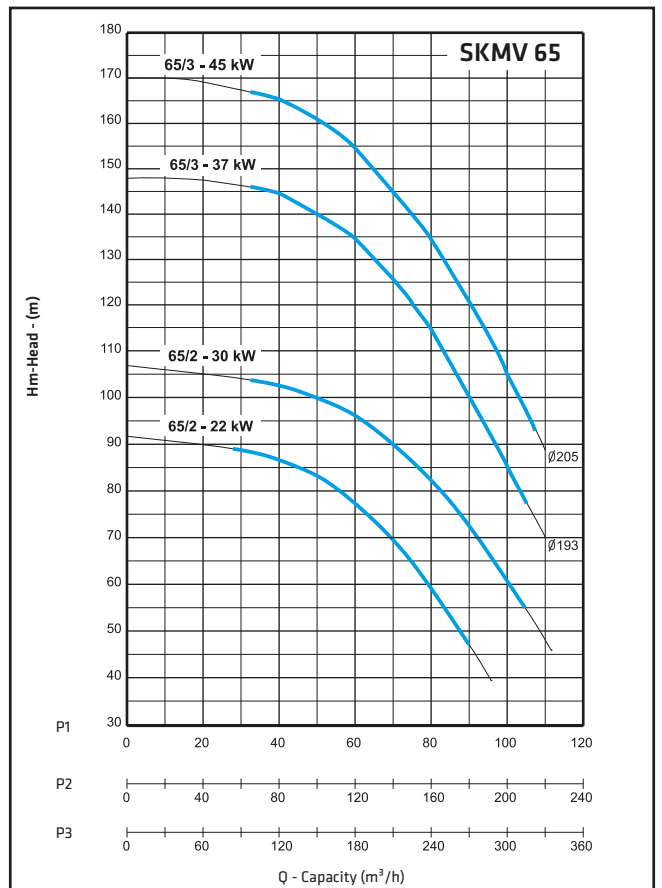
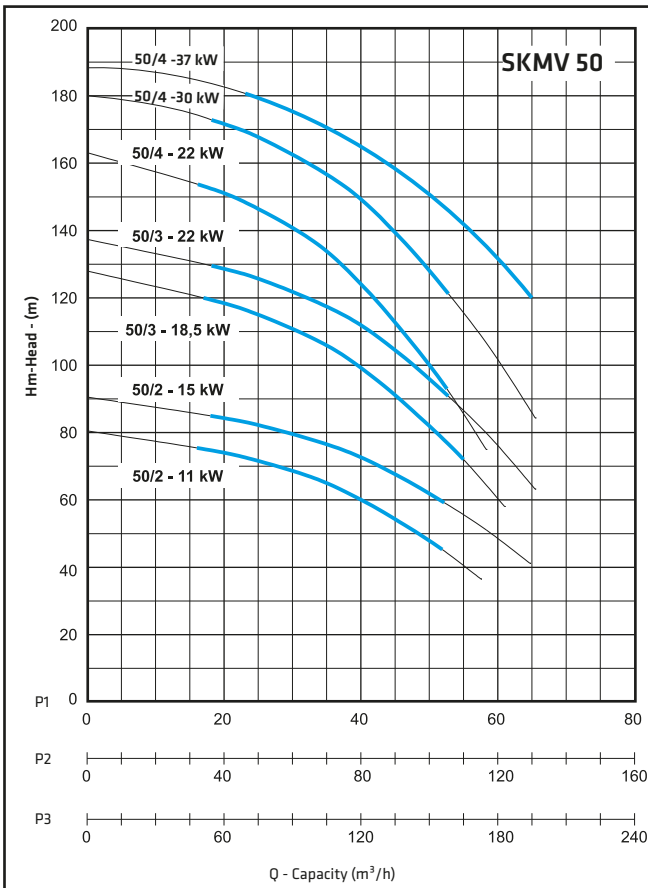
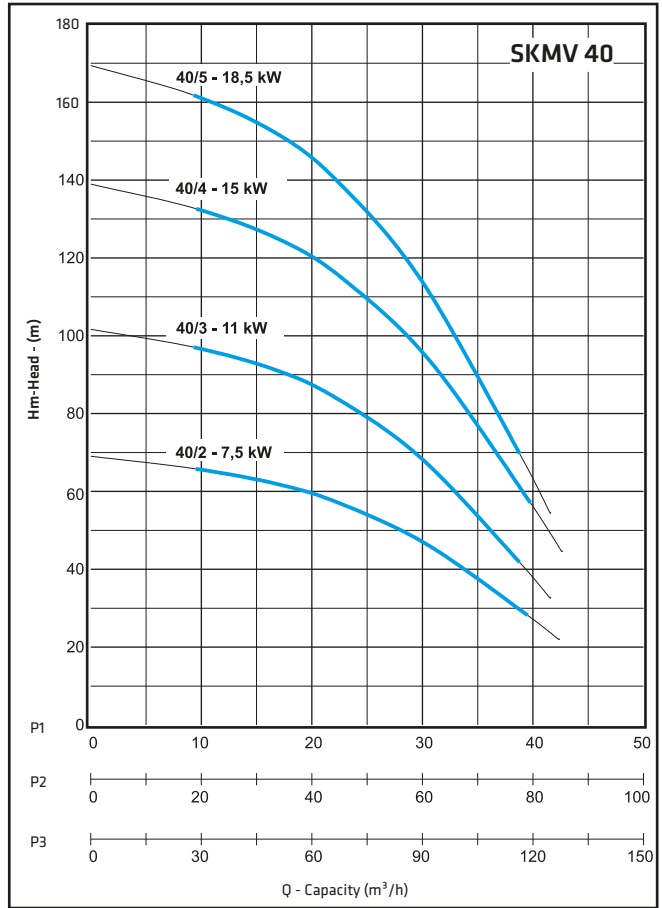
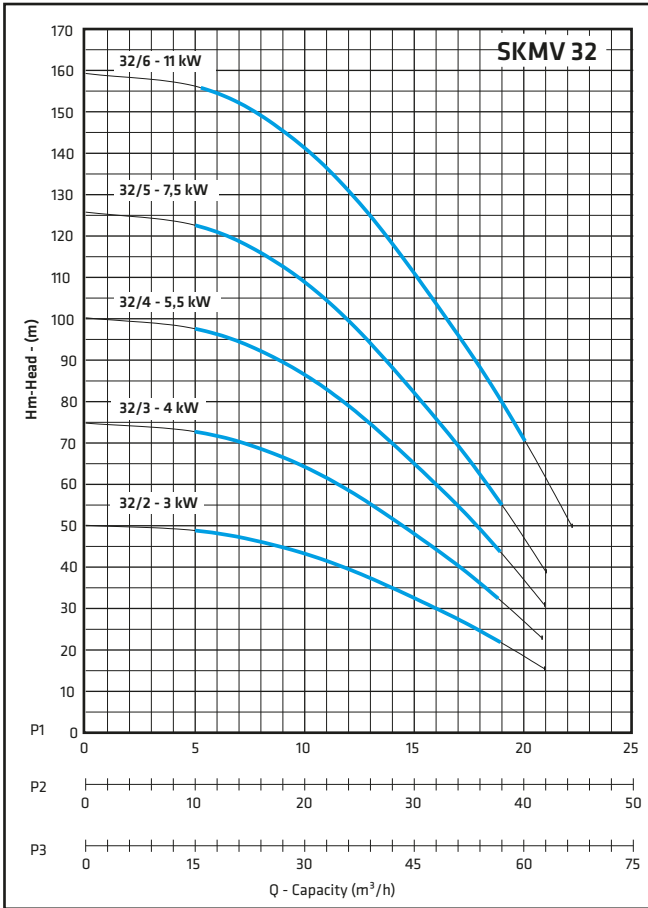

Dimensions

TH SKMV



Kalasanati.com

Pump Type	Motor		Dimensions (mm)						
	kW	IEC	A	B	h	d	h1	h2	kg
1 x SKMV 32/2	3	100L	480	380	750	R 2"	150	265	115
1 x SKMV 32/3	4	112M			800			315	180
1 x SKMV 32/4	5.5	132S			890			355	215
1 x SKMV 32/5	7.5	132S			990			395	225
1 x SKMV 32/6	11	160M			1050			445	280
2 x SKMV 32/2	3	100L	650	855	1100	R2½"	220	116	235
2 x SKMV 32/3	4	112M			1100			160	365
2 x SKMV 32/4	5.5	132S			1150			205	435
2 x SKMV 32/5	7.5	132S			1200			248	455
2 x SKMV 32/6	11	160M			1400			295	570
3 x SKMV 32/2	3	100L	960	885	1200	R 3"	220	116	340
3 x SKMV 32/3	4	112M			1200			160	540
3 x SKMV 32/4	5.5	132S			1250			205	640
3 x SKMV 32/5	7.5	132S			1350			248	675
3 x SKMV 32/6	11	160M			1400			295	845
1 x SKMV 40/2	7.5	132S	480	380	905	R2½"	150	280	165
1 x SKMV 40/3	11	160M			965			340	200
1 x SKMV 40/4	15	160M			1115			395	225
1 x SKMV 40/5	18.5	160L			1170			450	245
2 x SKMV 40/2	7.5	132S	680	995	1100	R 4"	220	130	350
2 x SKMV 40/3	11	160M			1365			190	425
2 x SKMV 40/4	15	160M			1365			245	465
2 x SKMV 40/5	18.5	160L			1365			300	515
3 x SKMV 40/2	7.5	132S	1030	1015	1100	R 5"	220	135	515
3 x SKMV 40/3	11	160M			1365			190	630
3 x SKMV 40/4	15	160M			1565			245	695
3 x SKMV 40/5	18.5	160L			1565			300	760
1 x SKMV 50/2	11	160M	500	465	1060	R 3"	160	320	235
	15	160M			1060			320	245
1 x SKMV 50/3	18.5	160L			1125			380	275
	22	180M			1125			380	300
1 x SKMV 50/4	22	180M			1185			395	325
	30	200L	1300	395	390				
	37	200L	1300	395	390				
2 x SKMV 50/2	11	160M	800	1115	1365	R 5"	225	156	540
	15	160M			1365			156	550
2 x SKMV 50/3	18.5	160L			1365			220	615
	22	180M			1365			220	665
2 x SKMV 50/4	22	180M			1565			285	715
	30	200L	1565	285	830				
	37	200L	1565	285	830				
3 x SKMV 50/2	11	160M	1200	1150	1380	R 6"	250	156	800
	15	160M			1380			156	815
3 x SKMV 50/3	18.5	160L			1380			220	915
	22	180M			1380			220	985
3 x SKMV 50/4	22	180M			1580			285	1060
	30	200L	1580	285	1220				
	37	200L	1580	285	1220				
1 x SKMV 65/2	22	180M	600	880	1300	R 5"	180	365	330
	30	200L			1300			365	385
1 x SKMV 65/3	37	200M	600	880	1300	R 5"	180	435	420
	45	225L			1300			435	515
2 x SKMV 65/2	22	180M	900	1380	1600	R 6"	280	200	705
	30	200L			1600			200	810
2 x SKMV 65/3	37	200M	900	1380	1900	R 6"	280	255	880
	45	225L			1900			255	1030
3 x SKMV 65/2	22	180M	1350	1500	1600	R 8"	290	200	1055
	30	200L			1600			200	1215
3 x SKMV 65/3	37	200M	1350	1500	1900	R 8"	290	255	1320
	45	225L			1900			255	1545

Dimensions might be changed.

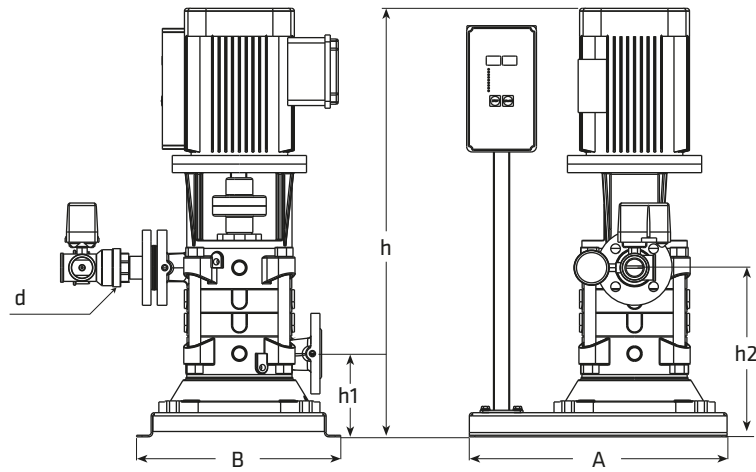

Design No : D. 1

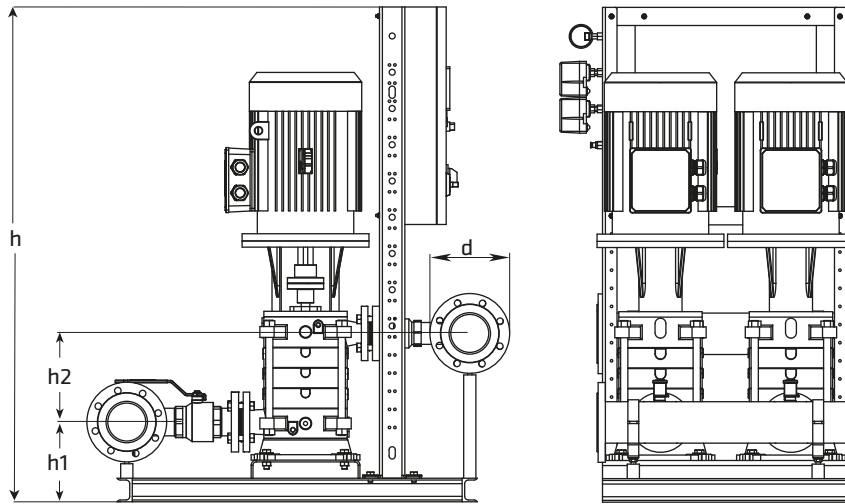

Design No : D. 2

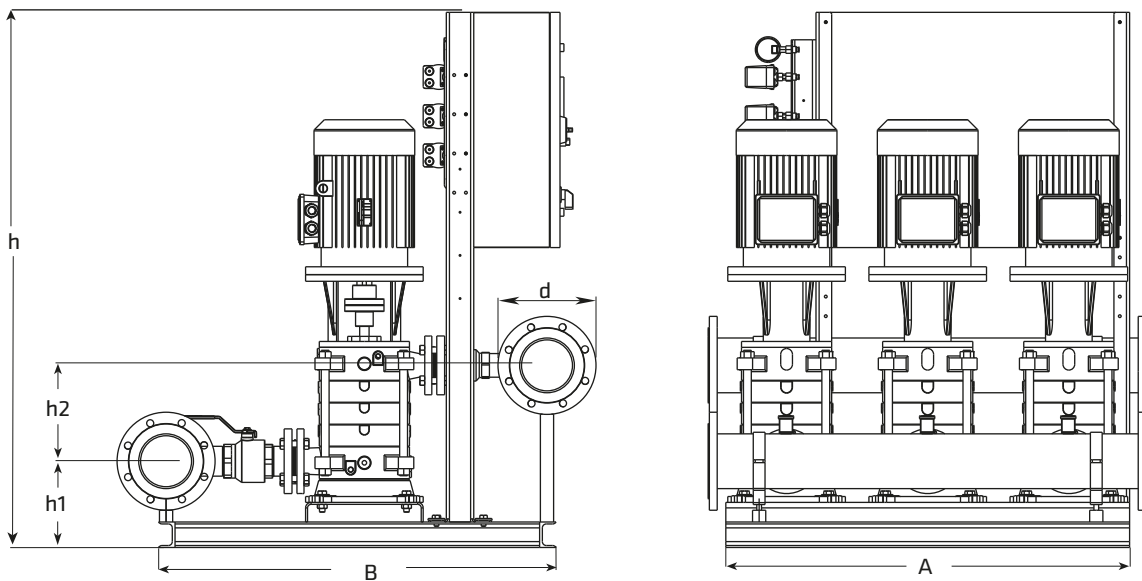

Design No : D. 2



Pump • Fire Fighting Units • Booster Set

TH GRV-VD / VB BOOSTERS



Kalasanati.com



General Information

High pressure, quiet running, compact and low power consumption.

GRV-VD / VB pumps are suitable for pumping non-abrasive, clean or slightly contaminated, low viscosity without solid & fibrous particles liquids.

Vertical structure saves space.

Technical Data

Capacity _____ up to 60 m³/h

Head _____ up to 170 m

Casing Pressure _____ 10-16-25 bar

Design Temperature _____ up to 50 °C

Design Features

- TH GRV-VD / VB boosters are manufactured with vertical pump.
- The boosters are produced as single, double and triple pumps as a standard according to the desired flow. Upon request, up to 6 pumps can be set.
- Single-pump boosters have a water level float (electric floater).
- Phase control system (PCS) is available in single pump, three-phase motorized boosters.
- Sequencing, phase control and liquid level control are standard features for multiple pumped booster pumps.
- Booster pumps can operate in two different modes; automatically and manually.

Booster Designation

TH 1 x GRV-VD 5

Booster Type _____
 Number of Pumps _____
 Pump Type _____
 Number of Stage _____

- Electric motors of high efficiency class conforming to IEC 60034-30 standard are used.
- The booster pumps can be manufactured as a variable-speed frequency control for convenience. (upon request)

Material Information

Part Name	Material	
	Standard	Optional
Pump		
Base Plate	GG 25	Bronz / AISI 304
Stage Casing	NORYL	Bronz / AISI 304
Intermediate Stage	NORYL	Bronz / AISI 304
Impeller	NORYL	Bronz / AISI 304
Shaft	AISI 420	AISI 304
Cover Plate	AISI 304	-
Panel	Pressure Switch Controlled	Frequency Controlled
Collector	Galvanized Steel	AISI 304
Frame	Fabricated Steel	Galvanized Steel
Accessories		
Valve	Brass	AISI 304
Check Valve	Brass	AISI 316



Performance Curve and Dimension Charts

TH GRV-VD / VB

Kalasanati.com

Pump Type	Motor		Dimensions (mm)																
	kW	IEC	A	B	B(max)	Ka	Kb	h	d	h1	h2	KG							
1x GRV-VD 3	1.5	90S	430	300	480	410	240	740	R1½"	135	265	70							
1x GRV-VD 4	2.2	90L						780			305	75							
1x GRV-VD 5	3	100L						820			345	85							
1x GRV-VD 6	4	112M						860			386	100							
1x GRV-VD 7	4							900			427	105							
1x GRV-VD 8	5.5	132S						940			467	125							
1x GRV-VD 9	5.5							980			507	130							
1x GRV-VD 10	7.5							1020			547	135							
2x GRV-VD 3	1.5							90S			520	730	760	500	580	1075	R2"	170	300
2x GRV-VD 4	2.2	90L						1075								340			165
2x GRV-VD 5	3	100L	1075	380	185														
2x GRV-VD 6	4	112M	1075	420	210														
2x GRV-VD 7	4		1075	460	215														
2x GRV-VD 8	5.5	132S	1075	500	260														
2x GRV-VD 9	5.5		1125	540	270														
2x GRV-VD 10	7.5		1365	580	275														
3x GRV-VD 3	1.5		90S	790	730	780	770	580	1175	R2½"						140			300
3x GRV-VD 4	2.2	90L	1175						340										240
3x GRV-VD 5	3	100L	1175						380		270								
3x GRV-VD 6	4	112M	1275						420		305								
3x GRV-VD 7	4		1275						460		315								
3x GRV-VD 8	5.5	132S	1325						500		390								
3x GRV-VD 9	5.5		1375						540		395								
3x GRV-VD 10	7.5		1500						580		405								

Dimensions might be changed.

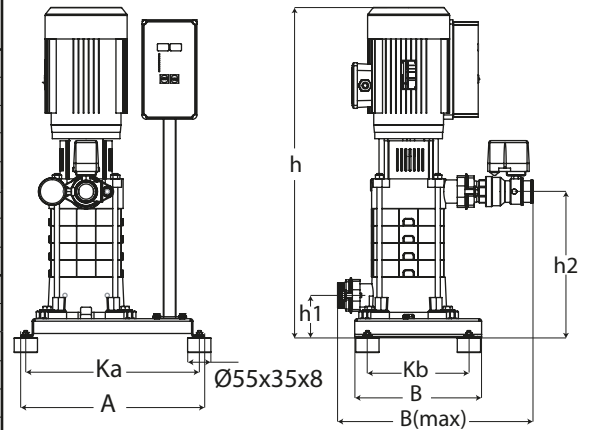

Booster set with one pump

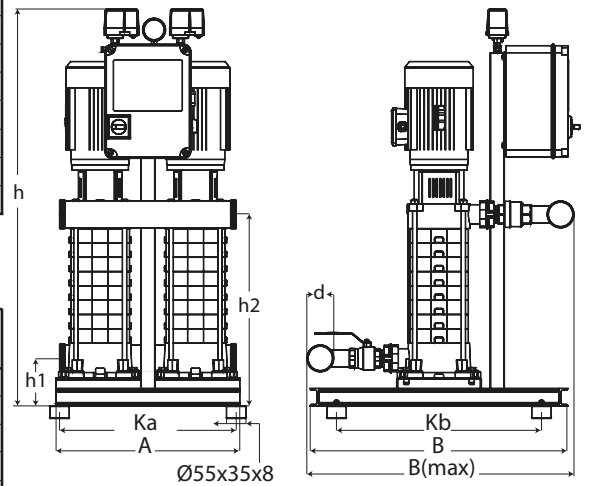

Booster set with two pump

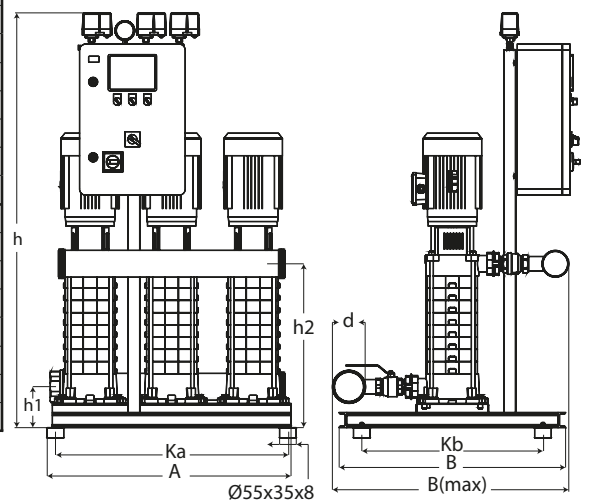

Booster set with three pump

Pump Type	Motor		Dimensions (mm)																
	kW	IEC	A	B	B(max)	Ka	Kb	h	d	h1	h2	KG							
1x GRV-VB 3	2.2	90L	435	300	465	410	240	740	R2"	100	265	70							
1x GRV-VB 4	3	100L						780			305	75							
1x GRV-VB 5	4	112M						820			345	85							
1x GRV-VB 6	5.5	132S						860			386	100							
1x GRV-VB 7	5.5							900			427	105							
1x GRV-VB 8	7.5	160M						940			467	125							
1x GRV-VB 9	7.5							980			507	130							
1x GRV-VB 10	11							1020			547	135							
2x GRV-VB 3	2.2							90L			520	730	760	500	580	1075	R2½"	135	300
2x GRV-VB 4	3	100L						1075								340			165
2x GRV-VB 5	4	112M	1075	380	185														
2x GRV-VB 6	5.5	132S	1075	420	210														
2x GRV-VB 7	5.5		1075	460	215														
2x GRV-VB 8	7.5	160M	1075	500	260														
2x GRV-VB 9	7.5		1125	540	270														
2x GRV-VB 10	11		1365	580	275														
3x GRV-VB 3	2.2		90L	790	750	780	770	580	1175	R3"						135			300
3x GRV-VB 4	3	100L	1175						340										240
3x GRV-VB 5	4	112M	1175						380		270								
3x GRV-VB 6	5.5	132S	1275						420		305								
3x GRV-VB 7	5.5		1275						460		315								
3x GRV-VB 8	7.5	160M	1325						500		390								
3x GRV-VB 9	7.5		1375						540		395								
3x GRV-VB 10	11		1500						600		405								

Dimensions might be changed.

Performance Curve

TH GRV-VD / VB



Kalasanati.com

GRV-VD

$n_s = 2900 \text{ rpm}$

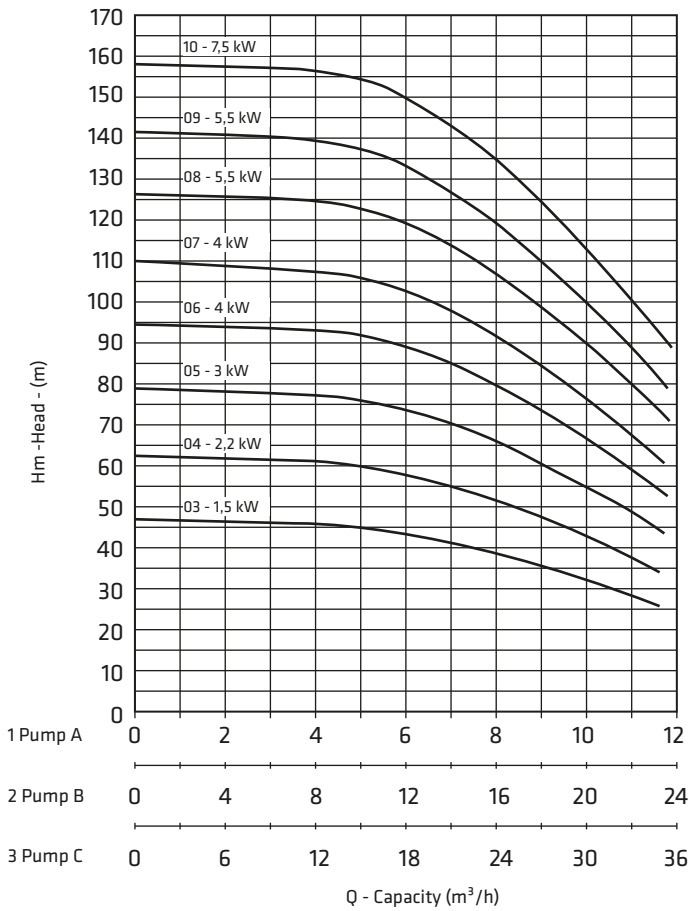

GRV-VB

$n_s = 2900 \text{ rpm}$

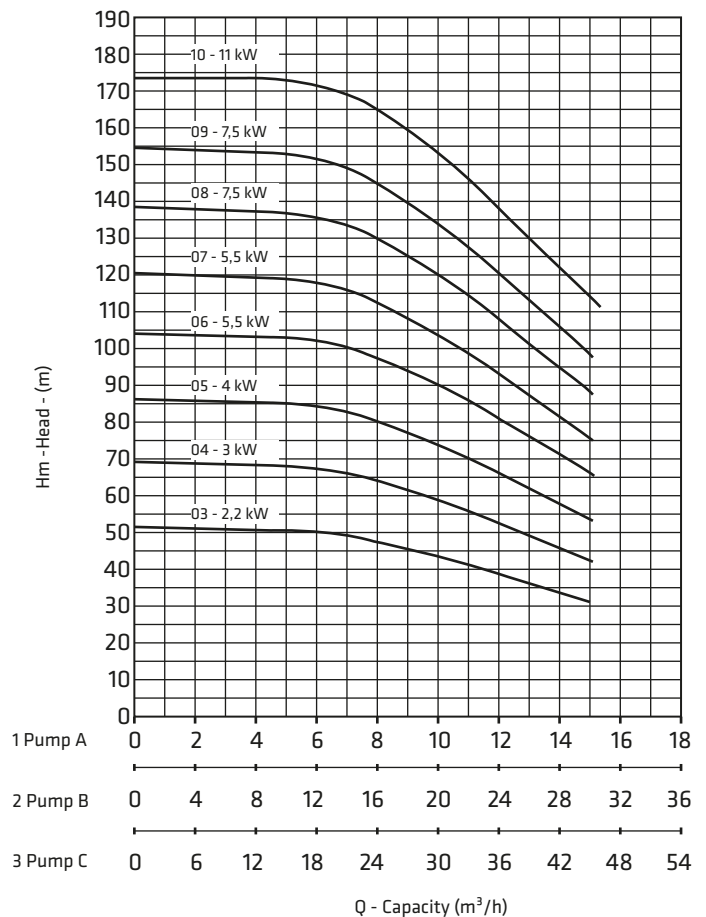



FIRE PUMPS



Kalasanati.com

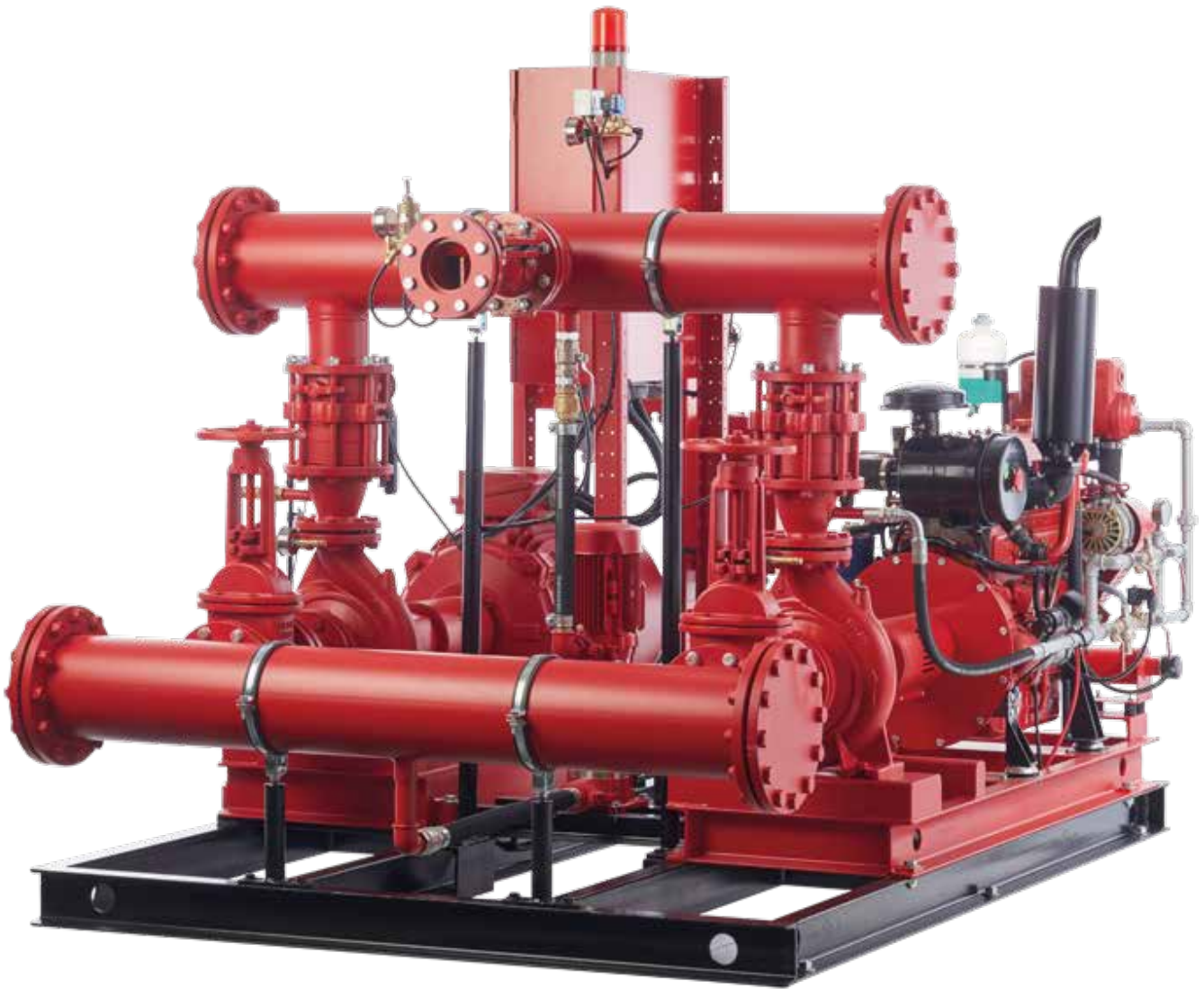



FIRE PUMPS CONFORM TO NFPA 20



Kalasanati.com

NFPA 20 standard defines the installation requirements of the fixed pumps for fire protection. This standard is the most common and the most detailed standard in the world used for fire protection services.

The scope of NFPA 20 document include the selection of fire pumps, installation, acceptance tests and operation.

Standart Pompa, being a member of NFPA, follows all studies and publications related within the fire protection area.

Most of the consultant companies related with fire protection system design are making their designs according to NFPA standards. Besides, insurance companies are not taking risk and reducing the policy costs, if the fire system is not designed according to NFPA standards and the fire pumps are not selected according to NFPA 20.

STANDART Fire Fighting Pump Features

STANDART fire pumps are used to pressurize and keep the pressure of fire fighting systems such as;

- Sprinkler
- Fire Cabinets
- Hydrants

Different type of pumps may be used in fire fighting systems;

- End suction pumps
- Vertical in-line pumps
- Double suction split-case pumps
- Multistage pumps

STANDART Fire pumps and groups conform the requirements of NFPA 20

- Seperate controller for each pump.
- Max. flow velocity in suction pipe is below 3 m/s at rated capacity
- Pressure at zero flow is less than 1.4 times rated pressure
- Pressure at 1.5 x rated capacity is not less than 0.65 x rated pressure
- Service factor shall not exceed 1.15
- Materials;

Casing	: Cast iron
Impeller	: Bronze
Shaft	: Stainless steel
- Shaft sealing: Soft packing or mechanical seal
- Bearings: L-10 rating of not less than 5000 hours at maximum load.
- Flanges according to EN 1092-2 PN 16.

Suggested accesories on the pump

- Automatic air release valve
- Circulation relief valve
- Increaser and reducer piping elements
- Pressure gauges at suction and discharge
- Flexible coupling



Fire Pump Performance Characteristics Conform to NFPA 20

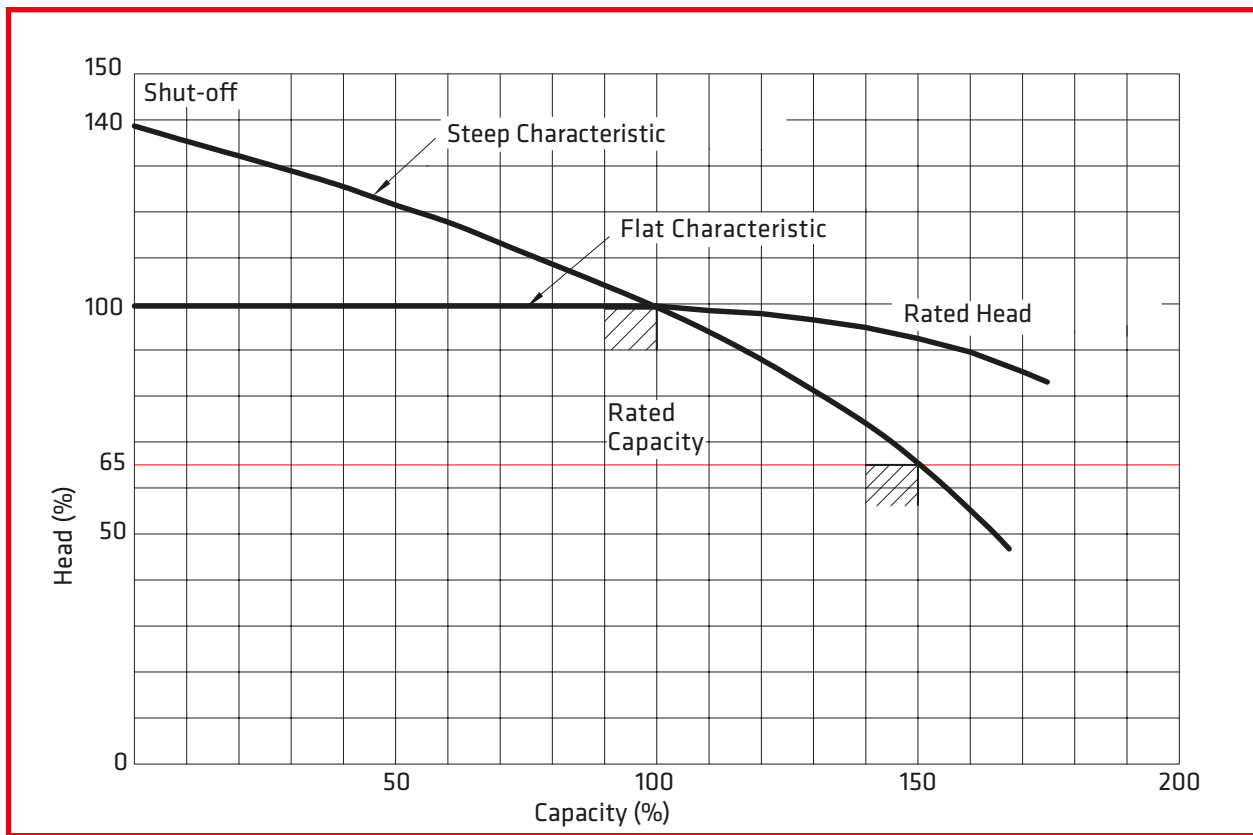

Fire Pump Capacities Conform to NFPA 20

Rated capacities as per NFPA 20 [2016]

(GPM)	(l/min)	(m ³ /h)
25	95	5,7
50	189	11,4
100	379	22,7
150	568	34,1
200	757	45,4
250	946	56,8
300	1136	68,1
400	1514	91
450	1703	102
500	1892	114
750	2893	170
1000	3785	227
1250	4731	284
1500	5677	341
2000	7570	454
2500	9462	568
3000	11355	681
3500	13247	795
4000	15140	908
4500	17032	1022
5000	18925	1136



STANDART Fire Pump Types

SNT End Suction



Horizontal, radially split volute casing type , single stage, end suction centrifugal pump with closed impeller.

rated capacities (GPM)			rated pressures (m)
25	400	2000	40
50	450	2500	50
100	500	3000	60
150	750	3500	70
200	1000	4000	80
250	1250	4500	90
300	1500	5000	100

SDS Double Suction

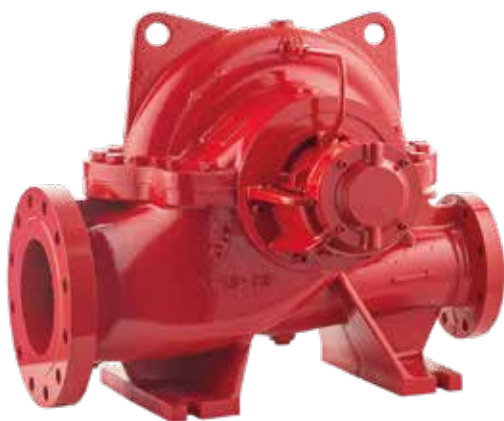

Horizontal, single stage, axially split volute casing pumps with double suction radial impellers.

rated capacities (GPM)		rated pressures (m)
400	2000	50
450	2500	60
500	3000	70
750	3500	80
1000	4000	90
1250	4500	100
1500	5000	110
		120
		140

SKM Multistage



Horizontal ring section multistage centrifugal pumps with closed impellers and diffusers.

rated capacities (GPM)			rated pressures (m)	
25	300	1000	60	120
50	400	1250	70	130
100	450	1500	80	140
150	500	2000	90	150
200	750	2500	100	160
250			110	170

SKM Multistage - Multioutlet



Multioutlet design horizontal ring section multistage centrifugal pumps with closed impellers and diffusers.

rated capacities (GPM)			rated pressures (m)	
25	300	1000	60	120
50	400	1250	70	130
100	450	1500	80	140
150	500	2000	90	150
200	750	2500	100	160
250			110	170

Fire Pump with Electric Motor

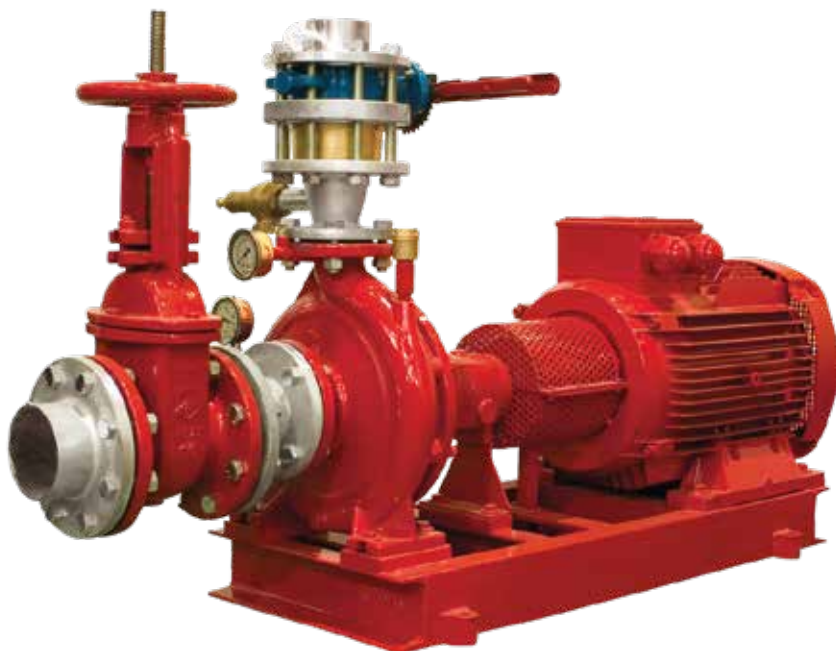

Fire Pump with Diesel Engine

Generally 100 % redundancy is obtained by diesel engine-driven pumps. The requirements of diesel engine-driven pumps are defined in NFPA 20.



Jockey Pump

Jockey pumps should be selected at a capacity at which to increase the system pressure to the required value in 10 minutes after sensing the leakage in fire fighting system.

Generally a pump with % 3 of rated capacity (min 1 GPM), % 110 of rated pressure.





Fire Pump Group Operation Algorithm

Manual Electric Control

The manually operated switch (push button) can be used to run the motor manually. In this case operation can not be affected by the pressure-actuated switch.

Mechanical Control

Emergency run handle on the controller can be used to operate pumps by mechanically closing the motor-circuit switching mechanism.

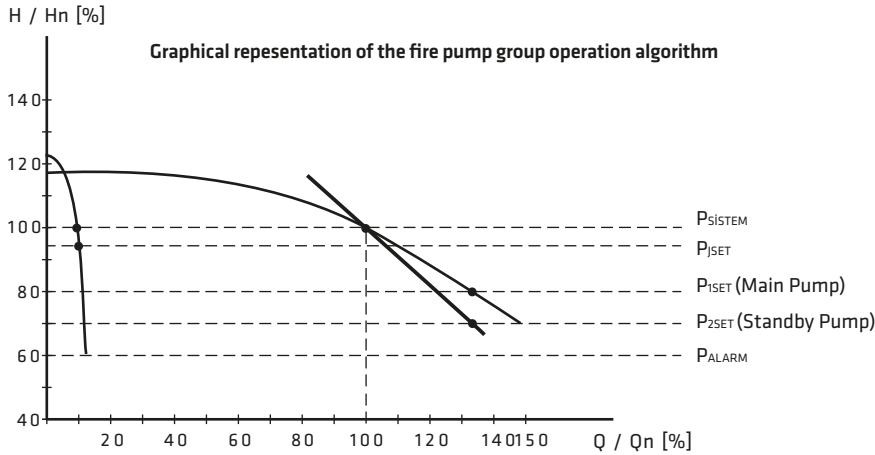

If the pressure drops below the set value (P_{JSET}), jockey pump starts running with the signal coming from the pressure switch and continues to run for 10 minutes until the system pressure reaches the set value (P_{SYSTEM}). If the pressure continues to drop, (P_{ISET}) first the main pump starts to run. If the system pressure (P_{SYSTEM}) can not supplied and pressure continues the drop

P&I Diagram for Fire Fighting Groups Conform to NFPA20

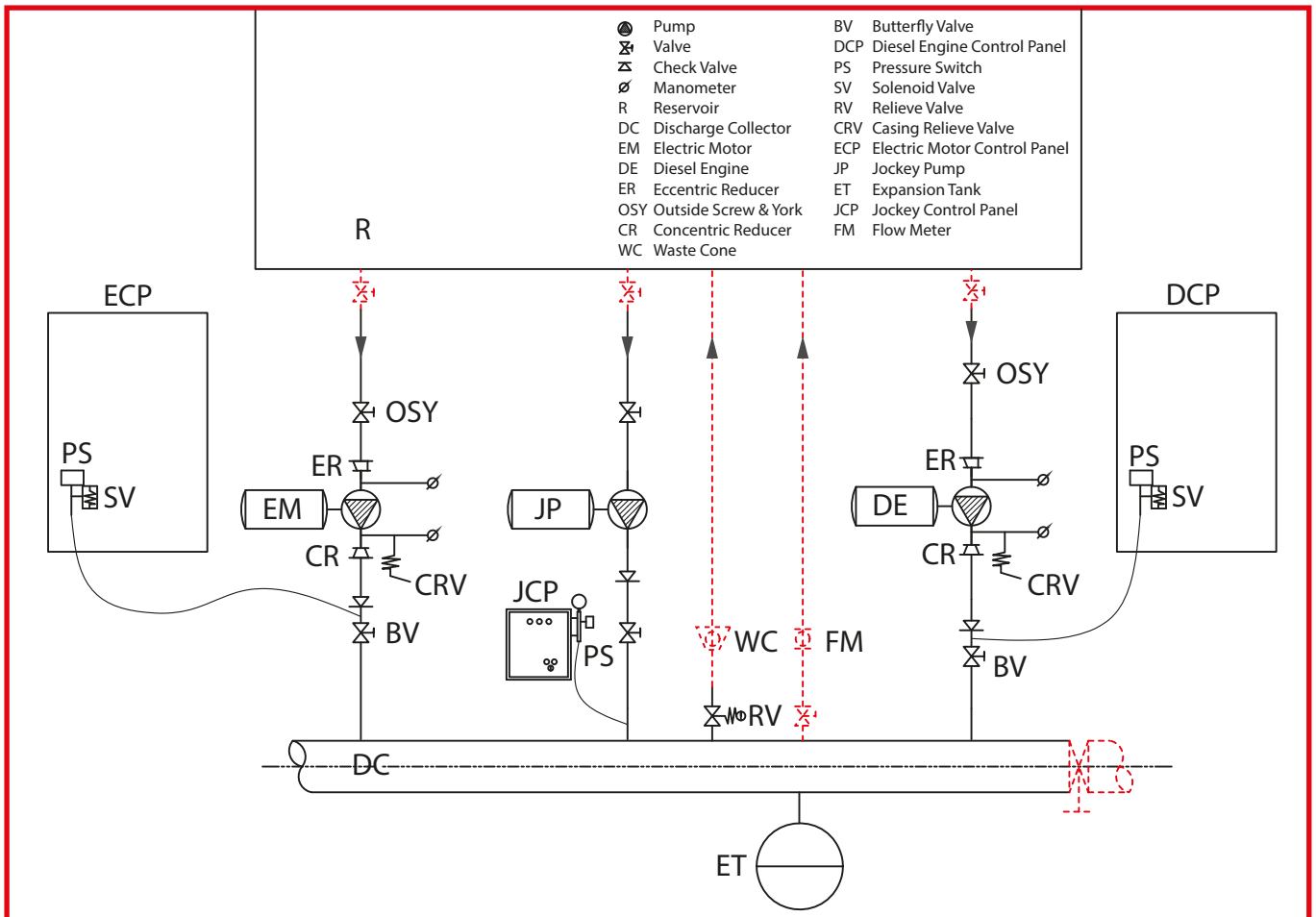

Automatic Operation Algorithm In Case Of Fire



Kalasanati.com

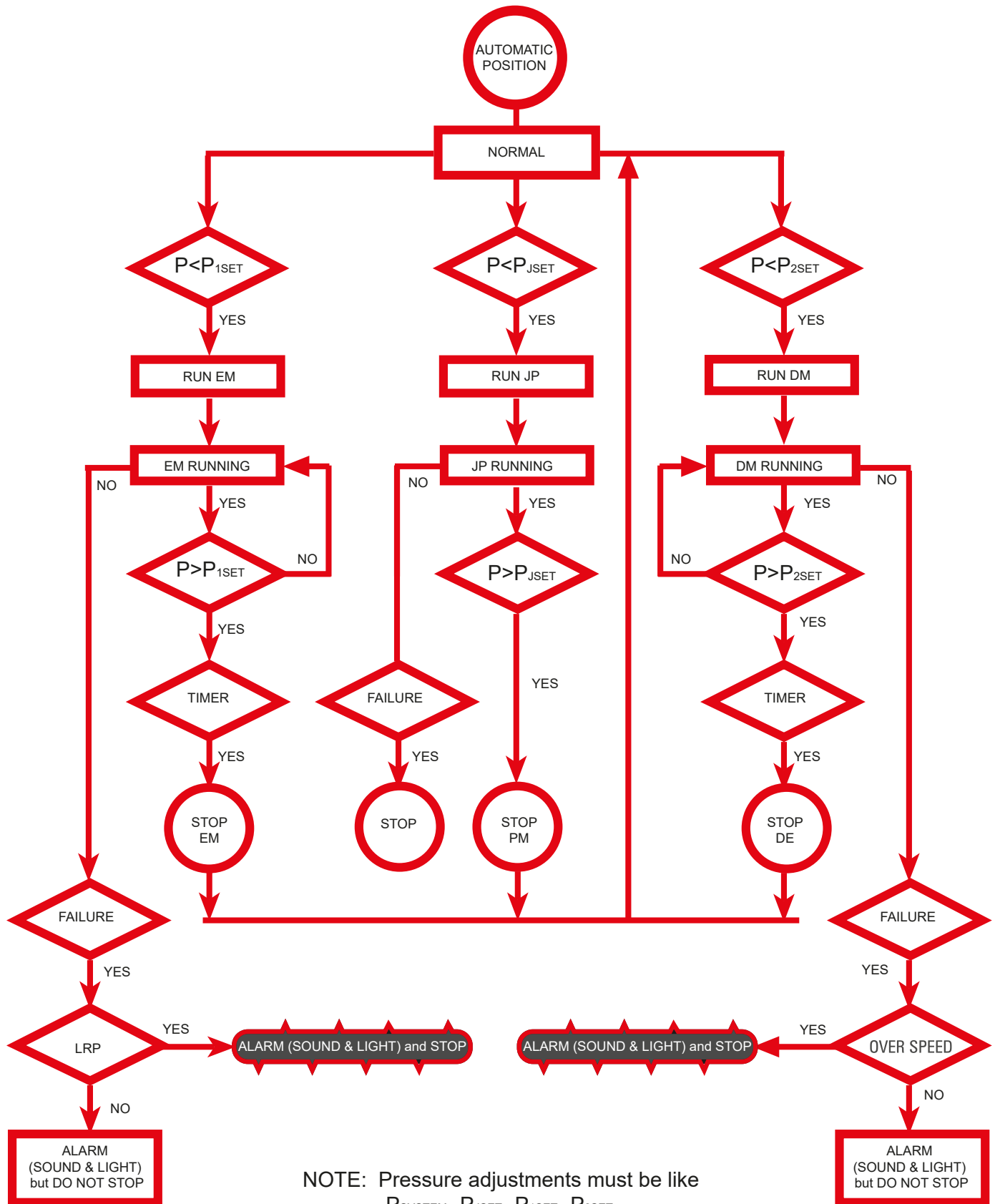

Control Panel



Kalasanati.com

Control Panels According to NFPA 20

For Electric Motor

For Diesel Engine



The pictures are representative.



Kalasanati.com

Fire Pump Group Control System

- Individual control panels are used for electric pump, diesel pump and jockey pump
- Lock mechanism are used on panels
- Continuous grounding
- Pumps can run by manual control and emergency-run mechanical control on controller
- By the help of Locked Rotor Protection (LRP), in case of locking rotor main switch is automatically shut down.
- No thermic protection on controller (except jockey pump controller)
- Alarm signals on electric pump controller (except jockey pump)

1. pump running
2. pump failure
3. minimum water level(if required)
4. phase reversal
5. loss of phase
6. power suitable
7. lamp test (if required)
8. audible(can be switched off) and visible(can not be switched off) alarms
9. LRP

- Two 12 V batteries for diesel engine
- Battery chargers
- Additive alarm signals for diesel driven pumps

1. high motor temperature
2. low oil pressure
3. over speed
4. control is in automatic mode
5. charger lamp
6. failure of 1st battery
7. failure of 2nd battery
8. starting failure
9. failure of battery charger
10. engine running
11. lamp test button (optional)
12. audible(can be switched off) and visible(can not be switched off) alarms

STANDART fire pump groups can communicate with building automation systems. But to operate and stop fire pump groups from the control room is not suggested because of safety reasons.

Pressure switches are very important, because they generate “run command”. There shall be at least one pressure switch for each pump and at least two for the system.

After the adjustments pressure switches should be locked at the factory. They should be in control panel and not effected from vibrations. Min and max set levels could be adjusted individually.

Fire pumps should operate automatically by pressure switches and also should operate manually by pressing an electric push button or pressing a mechanical handle.



Periodic Tests During Operation

Weekly Automatic Test

The timer which is preset at a certain time of the week, opens the solenoid valve. System pressure decreases due to discharge water and solenoid valve is closed after motor starts running. Pump runs for a period which is already programmed and then stops.

During weekly tests the fire security person is supposed to be at the test area (It is not easy to recognise mechanical failures during automatic test).

Minimum run time is 10 minutes for electric motor driven pumps and 30 minutes for diesel engine driven pumps. Diesel engine controller should generate an alarm signal in case of failure which is 15 seconds of cranking and 15 seconds of rest, in six consecutive cycles.

Weekly Manual Test

After completion of automatic weekly tests, manual-electrical (by pressing a button on controller) and manual-mechanical (by pressing a handle on controller) tests are done for a short period of time.

Monthly and Annual Test

These tests are for the purpose of protective maintenance and defined in NFPA -25

Standart Pompa technical team is ready to help on this matter if required.

Factory Test

Each fire pump is hydrostatically tested 1.5 times of shut off pressure (not less than 17 bars) for a minimum 5 minutes period.

Each fire pump is factory tested as per NFPA-20 requirement.

Fire pump groups and fire booster sets are functionally tested at factory.

Optional Accessories of Fire Pump Group (*)

Standart fire pump groups include all the required elements per NFPA-20.

Optional elements are shown below :

- suction valve position monitoring switch
- suction valve lock
- waste cone
- discharge valve position monitoring switch
- discharge valve lock
- flowmeter at the flow rate 1.75 times of rated flow

(*) **Fire Pump Group** : Main pump, stand-by pump, jockey pump, electric control panels, collectors, valves etc. all on common base plate.



Automatic Weekly Test Algorithm

For Electric Pump

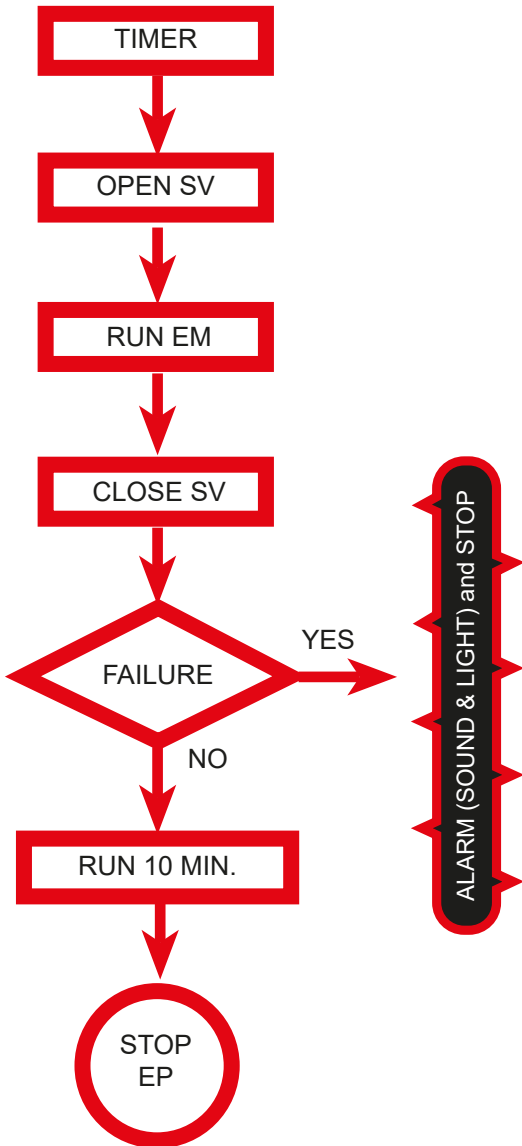

For Diesel Pump

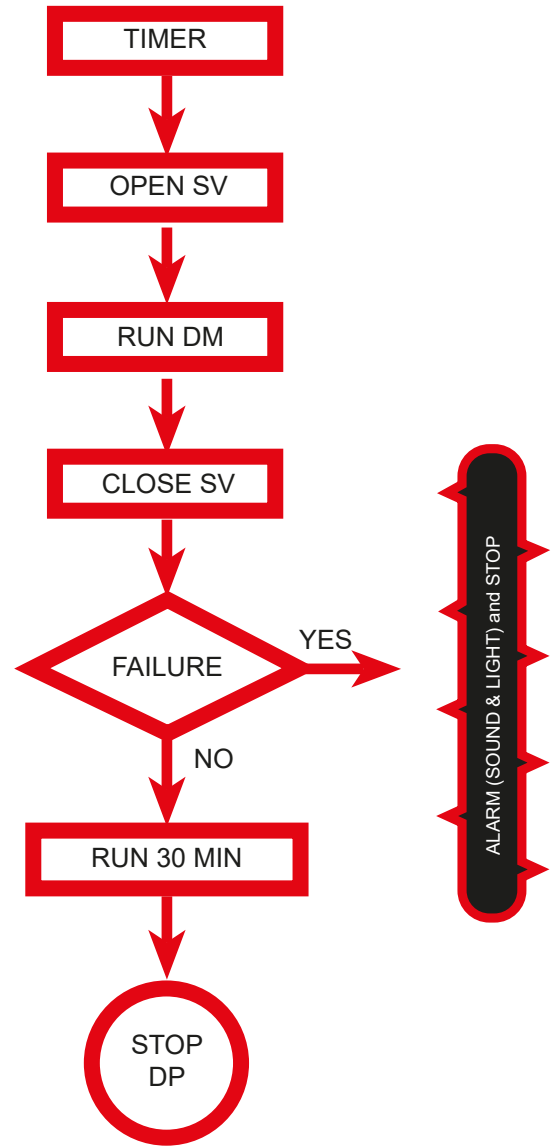



Kalasanati.com





Kalasanati.com

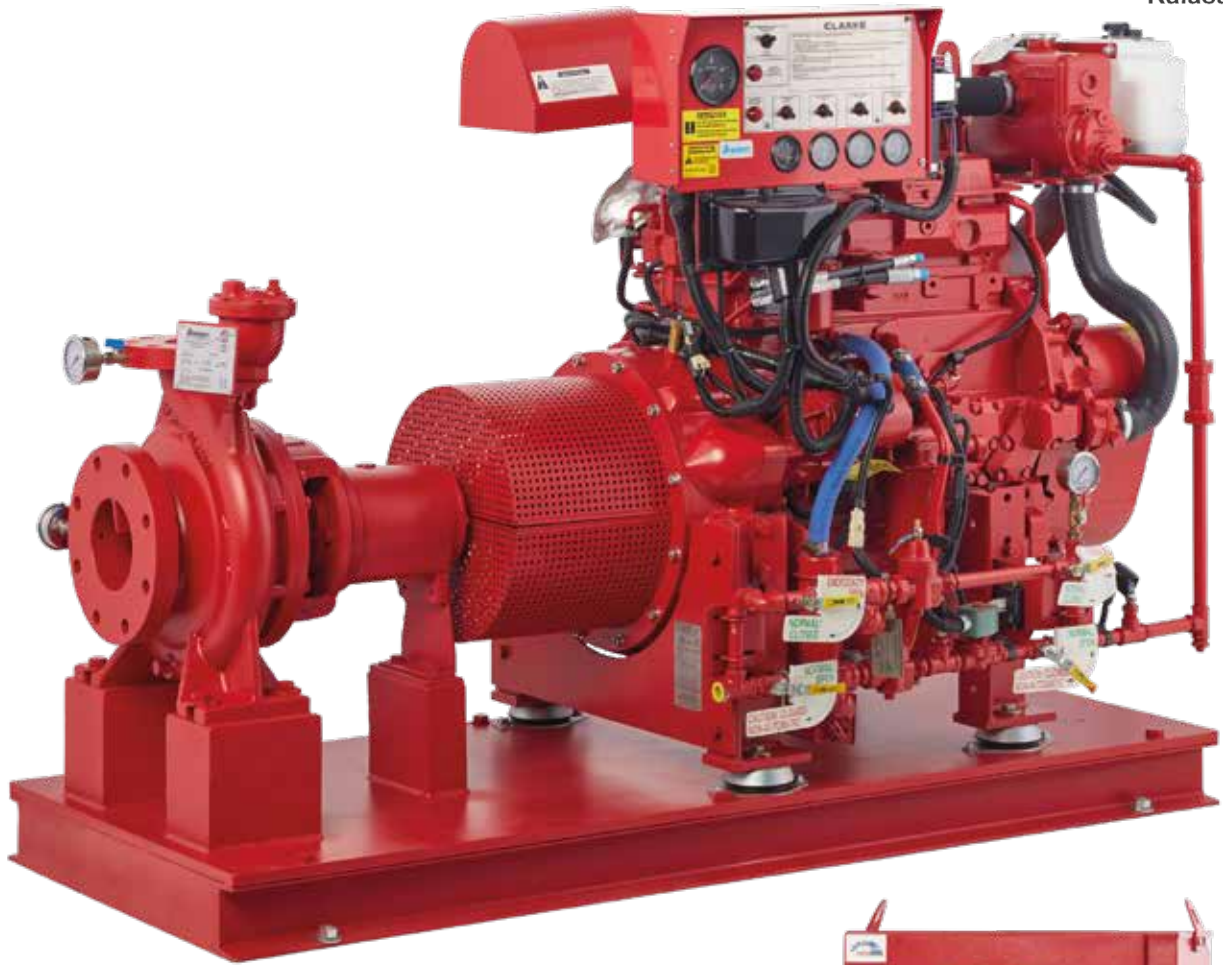



Pump • Fire Fighting Units • Booster Set

SDS / SNK

FIRE PUMPS



Kalasanati.com

Who UL is and What UL Does

- UL (Underwriters Laboratories Inc.) is a global independent safety science company offering expertise across five key strategic businesses: Product Safety, Environment, Life & Health, University and Verification Services. Since the year UL founded in 1894, nearly 70,000 manufacturers in 100 countries have produced 100.000 different types of totally 22 billion UL Marked products.
- UL engineers scientifically investigate and test thousands of types of products, materials, constructions and systems to evaluate the electrical, fire and injury risks; the burglary or fire resistance; or the ability to detect, control or limit fires.
- UL has developed 1,600 Standards for Safety, which serve as the bedrock of compliance in over 200 industries.
- There is an “Online Certifications Directory” in UL’s website and all the products listed by UL can be found here.

UL Safety Standard: UL 448

- The requirements of this standard cover design and test features of centrifugal fire pumps intended for use in water-supply systems for fire-protection service.
- The pumps covered by these requirements are intended for installation and use in accordance with the Standard for the Installation of Stationary Pumps for Fire Protection, NFPA 20.

Who FM is and What FM Does

- FM (Factory Mutual) Global is one of the world’s largest business property insurers who also serves engineering solutions to be protected against basicly fire, natural disaster or other types of property risk.
- FM Approvals is a unit of FM Global who certifies industrial and commercial products and services for companies. When a product or service meets the standards of FM Approvals, it is issued the “FM APPROVED” mark to signify it will perform as expected.
- Currently there are 60.000 certified products and services and these are listed in “FM Approval Guide” which can be found in FM website.

FM Approvals Standard: 1311 / 1319

- FM Class 1311 states approval criteria for horizontal or vertical split case centrifugal fire pumps while FM Class 1319 states about horizontal end suction centrifugal fire pumps that supply water to fire protection systems.
- The requirements in these standards are mainly based on ANSI Hydraulics Institute (HI) and NFPA 20 standards.

General Information



Kalasanati.com

Design Features According to UL & FM

• Only the specified capacities in the below table are allowed for rated capacity. For capacities higher than 5000 GPM, 500 GPM increments are allowed.

GPM	m ³ /h	GPM	m ³ /h	GPM	m ³ /h
25	5.68	400	90.8	2000	454
50	11.3	450	102.2	2500	568
100	22.7	500	113.5	3000	681
150	34.0	750	170	3500	795
200	45.4	1000	227	4000	909
250	56.8	1250	284	4500	1022
300	68.1	1500	341	5000	1136

- All interior bolt or screw that are exposed to pumped liquid shall be of rolled bronze or corrosion resistant material
- The pump shall be provided with automatic air-release valve, circulation relief valve and pressure gauges
- Bearings shall have an L-10 rating of not less than 5000 hours at maximum load.
- The pumps shall be provided with at least four packing rings plus a lantern ring. The lantern ring may be permitted to replace one ring of packing.
- Impellers, wear rings, shafts, lantern rings, glands shall be made of corrosion resistant material.
- Following material specifications are applied to STANDART UL/FM fire pumps:

Part List	Definition	DIN / EN		AISI / SAE / ASTM
Casing	Nodular Cast Iron	0.7040	EN-GJS-400-15 (GGG40)	A 536 60-40-18
Impeller	Cast Bronze	2.1050.01	G-CuSn 10	B427 C90700
Shaft	Stainless Steel	1.4021	X20 Cr 13	A 276 Type 420+QT
Shaft Seal	Stainless Steel	1.4404	X2 Cr Ni Mo 17-12-2	A 276 Type 316L
Wear Ring	Cast Bronze	2.1050.01	G-CuSn 10	B 427 C90700
Bolt & Screw	Stainless Steel	1.4301	X5 Cr Ni 18-10	A276 Type 304



Part List

001	Volute Casing
003	Stuffing Box
010	Support Foot
020	Wear Ring (back)
021	Wear Ring (front)
030	Bearing Housing
031	Bearing Bracket Lantern
034	Bearing Cover (outboard)
035	Bearing Cover (inboard)
042	Stuffing Box Gland
044	Lantern Ring
050	Impeller
060	Shaft
065	Impeller Nut
070	Shaft Protecting Sleeve
088	Thrower
200	Ball Bearing
210	Impeller Key
211	Coupling Key
212	Sleeve Key
230	Drain Plug
301	Stud+Nut+Washer
320	Hex. Head Bolt
321	Hex. Head Bolt
322	Hex. Head Bolt
323	Hex. Head Bolt
400	Stuffing Box Packing
405	Set Screw
410	Gasket
411	Gasket
420	O-Ring

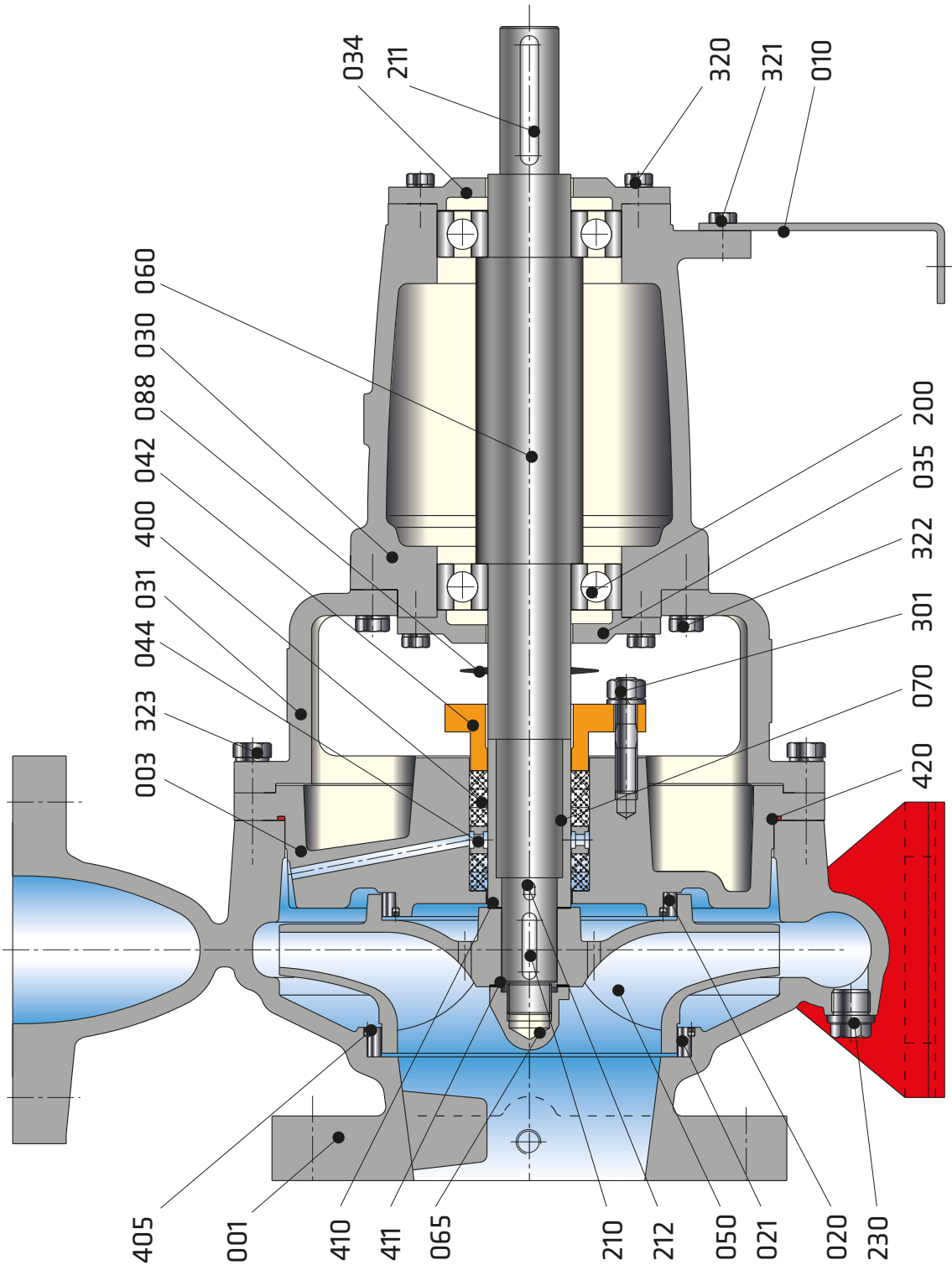

003	Stuffing Box (right side)
003A	Stuffing Box (left side)
013	Volute Casing (top)
014	Volute Casing (bottom)
020	Wear Ring
030	Bearing Housing
034	Bearing Cover (inboard)
034A	Bearing Cover (inboard)
035	Bearing Cover (outboard)
035A	Bearing Cover (outboard)
042	Stuffing Box Gland
044	Lantern Ring
050	Impeller
060	Shaft
070	Shaft Protecting Sleeve
071	Sleeve (spacer)
088	Thrower
200	Ball Bearing
210	Impeller Key
211	Coupling Key
212	Key
220	Oil Seal
231	Drain Plug
270	Nipple
271	Grease Nipple
300	Stud
320	Hex.Head Bolt
350	Allen Screw
360	Nut
390	Locknut (non drive end)
391	Locknut (drive end)
392	Lock Washer
400	Stuffing Box Packing
411	Gasket
420	O-Ring
421	O-Ring
430	Pin
500	Valve
501	Flushing Pipe

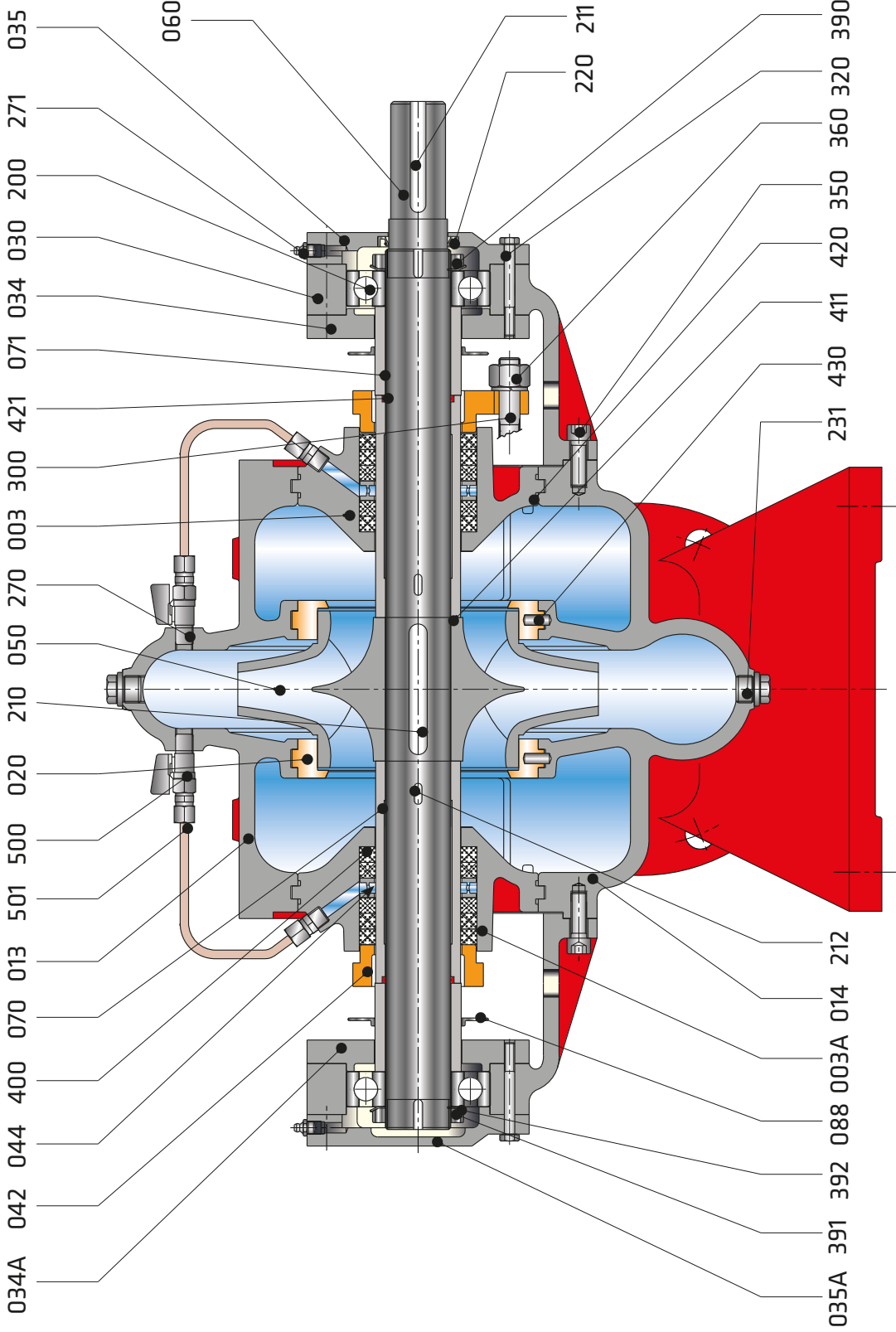

Selection Table



Kalasanati.com



UL Listed & FM Approved Fire Pumps			
Pump Type	Capacity (GPM)	Pressure Range (PSI)	Speed (RPM)
SDS 65-250	100	102-171	3000
	150	100-171	3000
	200	100-171	3000
	250	99-171	3000
	300	98-171	3000
SDS 80-250	400	103-162	3000
	450	102-162	3000
	500	102-161	3000
SDS 80-315	500	173-208	3000
	750	167-204	3000
SDS 100-250	750	89-172	3000
	1000	85-171	3000
SDS 125-315	1250	117-199	3000
	1500	112-198	3000
	2000	130-192	3000
SDS 150-315	2000	92-125	2100
	2000	116-156	2350
	2500	87-123	2100
	2500	113-156	2350

UL Listed & FM Approved Fire Pumps			
Pump Type	Capacity (GPM)	Pressure Range (PSI)	Speed (RPM)
SNK 50-250	200	93-150	3000
	250	91-150	3000
	300	88-148	3000
SNK 65-250	300	92-142	3000
	400	88-142	3000
SNK 80-250	450	84-141	3000
	450	87-148	3000
	500	84-148	3000

(*) NOTE :

- Engines are rated at standard SAE conditions of 29.61 inches (752 mm) Hg barometer and 77°F (25°C) inlet air temperature [approximates 300 ft. (91.4 m) above sea level] by the testing laboratory (see SAE Standard J 1349).
- A deduction of 3 percent from engine horsepower rating at standard SAE conditions shall be made for diesel engines for each 1000 ft. (305 m) altitude above 300 ft. (91.4 m)



kalasanati.com
Training, Selecting, Purchasing

info@kalasanati.com
Tel: 02191004647
